

***Preliminary Stormwater Pollution Protection Plan  
(SWPPP)***

*for*

***Trinitas Ventures***

*Townhomes at Dryden*

*Tax Map ID: 56.-5-19.3*

*56.-5-11*

*56.-5-12*

*56.-5-9*

*366 Dryden Road  
Town of Dryden, Tompkins County, New York*

*October 2018  
(revised March 2019)*

*HUNT #3177.001*

***HUNT*** E|A|S

Prepared by:  
Hunt Engineers, Architects & Land Surveyors, PC  
4 Commercial St., Suite 300  
Rochester, NY 14614-1008  
Phone: (585) 327-7950, Fax: (585) 327-7949

**Stormwater Pollution Prevention Plan (SWPPP)  
For  
Trinitas Ventures  
Townhomes at Dryden  
Town of Dryden, Tompkins County, New York  
October 2018 (revised March 2019)  
HUNT 3177-001**

**TABLE OF CONTENTS**

<b>1. BACKGROUND INFORMATION .....</b>	<b>1</b>
A. Project Location and Scope .....	1
B. Application Information .....	1
<b>2. STORMWATER MANAGEMENT OBJECTIVES.....</b>	<b>2</b>
<b>3. EXISTING CONDITIONS &amp; SITE PLANNING .....</b>	<b>2</b>
A. Descriptions of Existing Hydrology .....	2
B. Water Bodies and Wetlands Impacted by Site .....	4
C. Environmentally Sensitive Areas .....	4
D. TMDL Identification Requirements.....	4
E. Existing Utility Lines, Easements, Water Supply and Sewage Treatment.....	4
F. Soil Identification, Description and Hydrological Soil Group.....	4
G. Protection and Enhancement of Natural Resources.....	5
H. Acreage and Location of Proposed Impervious Areas .....	5
I. Initial Water Quality Volume.....	5
J. Required Runoff Reduction.....	5
<b>4. Post-Construction Storm Water Pollution Prevention Plan .....</b>	<b>5</b>
A. Proposed Development and SWPPP Description .....	5
B. Proposed Stormwater Management Plan and Drainage Areas.....	6
C. Provided Runoff Reduction .....	6
D. Final Water Quality Treatment Volume.....	6
E. Channel Protection.....	6
F. Overbank and Extreme Flood Control Analysis Results.....	7
G. Maintenance Agreement.....	7
<b>5. During Construction Storm Pollution Prevention Plan.....</b>	<b>7</b>
A. Acreage of Disturbed Area.....	7
B. Duration of Construction Activity.....	7
C. Pollution Prevention Measures .....	8
D. SWPPP Implementation and Inspection .....	8
E. Construction Site Log Book .....	8
F. Construction Sequence.....	9

**APPENDICES**

- A. Location & Soils Mapping
- B. N.O.I. & N.O.T.
- C. MS4 Acceptance Form
- D. Contractor's Certification
- E. Site Planning and Green Infrastructure Matrices
- F. Precipitation Data
- G. Stormwater Calculations
- H. Hydrology Calculations (Pond Pack Output)
- I. Rip Rap and Sediment Trap Calculations
- J. Geotechnical Report
- K. SHPO No Impact Letter
- L. Operations and Maintenance Manual
- M. Construction Site Log Book
- N. SPDES Permit No. GP-0-15-002
- O. Drainage Area Maps
- P. Ex. Storm Sewer Capacity Calculations
- Q. Selected Engineering Plans

**STORMWATER POLLUTION PREVENTION PLAN (SWPPP)  
FOR  
TRINITAS VENTURES  
TOWNHOMES AT DRYDEN**

1. Background Information

A. Project Location and Scope

The Proposed Townhomes project site is located on Dryden Road and mt. pleasant road in the town of Dryden, Tompkins County, New York. The subject property is comprised of a total of seven parcels that include Tax Map 56-5-9,11,12,19.4&19.3, 56-3-9 and 56-3-12. Several of the parcels are improved with structures and parking. All such existing improvements are to be demolished as part of the pending application. The Town of Dryden is a designated Municipal Separate Storm Sewer System (MS4) per NYSDEC mapping and the Town will be responsible to review and approve the ultimate stormwater management program for the project. See Appendix A for a location map outlining the limits of the proposed project. Trinitas Ventures, LLC is proposing to construct a townhome multi-family complex with 219 units with a mix of 552 single, two, three and four bedroom options.

This report has been completed without the benefit of a completion of a comprehensive geotechnical study currently underway. As such, this SWPPP is considered preliminary in nature and subject to change as additional information is received and considered. At this time development includes construction of a mix of approximately 425 surface and covered parking spaces, multistory residential apartments, access drives, a maintenance building, trash enclosures, a clubhouse, pool area with deck, retail space and landscaping. Construction of the project is expected to disturb 13.5 acres and will The project will disturb 13.2 acres and increase the total site impervious by approximately 6.7 acres.

Temporary and permanent erosion and sediment control measures are proposed in accordance with New York State Department of Environmental Conservation regulations to minimize erosion and transportation of sediment from the project site.

B. Application Information

A copy of the Notice of Intent (NOI), Notice of Termination (NOT), MS4 Acceptance Form and Contractor's certification for Stormwater Discharges Associated with Construction Activity, are included in Appendix B, C & D. The applicant is requesting permission from the New York State Department of Environmental Conservation (NYSDEC) to disturb more than one (1) acre on the site property in accordance with the enclosed Erosion and Sediment Control Plans and Stormwater Pollution Prevention Plan (SWPPP). Copies of the SWPPP shall remain on the jobsite with copies available at the request of and in accordance with the NYSDEC.

Contact information for owner: Trinitas Ventures  
Attn. Kimberly Hansen  
201 Main St  
Lafayette, IN 47901  
Phone: (765) 464-2800

## 2. Stormwater Management Objectives

To maintain the quality and quantity of off-site storm water, during and after the construction, the following Stormwater Management Objectives have been incorporated:

- On-site construction activities will utilize Best Management Practices (BMP's) to control the erosion of on-site soil and sediment through control measures indicated in the Erosion and Sedimentation Control Plan. All erosion and sediment control measures shall be installed and maintained in accordance with the New York State Guidelines for Urban Erosion and Sediment Control.
- Construction activities will include the stabilization of disturbed soils through a combination of temporary BMP's including temporary seeding or mulching along excavated areas, and dust control where appropriate.
- During construction, sediment control will be provided by the use of a variety of approved measures including silt sock, sediment traps, and a stabilized construction entrance. Once vegetation has reached 80 percent coverage these sediment control measures may be removed.
- The post-construction stormwater control systems have been designed using the five-step process, including site planning and storm water management practice (SMP) selection as follows:
  1. Site planning to preserve natural features and reduce impervious cover.
  2. Calculation of the water quality volume for the site.
  3. Incorporation of green infrastructure techniques and standard SMP's with Runoff Reduction Volume (RRv) capacity.
  4. Use of standard SMPs, where applicable, to treat the portion of water quality volume remaining after runoff reduction measures.
  5. Design of peak rate control practices for the overbank and extreme flood events.

### Rainfall Amounts

<b>Storm Event (Years)</b>	<b>24-hr Rainfall (Inches)</b>
90% Rainfall	1.0
1	2.01
10	3.84
25	4.70
100	6.01

Rainfall data from the Northeast Regional Climate Center – Extreme Precipitation Data

## 3. Existing Conditions & Site Planning

### A. Description of Existing Hydrology

The Development area can be broken down into three (3) distinct watersheds; for this purpose, they have been designated as Study Points 1, 2 and 3. Study Point 1 is located at the northwest corner of the site along Dryden Road. It contains 10.1 acres of



trees and brush from onsite contributing area and approximately 5.05 acres of woods from off site contributing area. Study Point 2 is located at the outlet of the proposed SWM retention pound. It is made up of 4.45 acres of onsite area mostly covered by woods. An offsite contributing drainage area of 108 acres (the majority of which is wooded) also comes through the site to Study Point 2. Study Points 1 and 2 both ultimately combine along Dryden Road before drainage is sent through a culvert to the north and on to Fall Creek.

Study Point 3 is located at the intersection of Dryden Road and Mt. Pleasant Rd. Contributing drainage area through the site is 5.8 acres from the subject property with 6.13 originating offsite but passing through the property on the way to Study Point 3.

**Existing Conditions**

<b>Watershed</b>	<b>Curve Number</b>	<b>Area (acres)</b>	<b>Tc (hours)</b>
DA-1a-PRE	77	6.31	.263
DA-1b-PRE	74	3.8	0.33
DA-1-PRE	85	5.05	0.50
DA-2A-PRE	77	4.45	0.167
DA-2A OFFSITE-PRE	78	108.04	0.60
DA-3-PRE	77	5.8	0.25
DA-3 OFFSITE-PRE	78	6.13	0.40

**B. Water Bodies and Wetlands Impacted by Site**

According to mapping available from the National Wetlands Inventory, the Project Site is not known to contain wetland areas, however, there is a wetland delineation within the site, copy of the existing conditions plans has been included as a reference. The entire site ultimately drains to fall Creek.

**C. Cultural and Environmentally Sensitive Areas**

As required by the SPDES Permit, the Historical Resource maps available online from the State Historical Preservation Office (SHPO) have been consulted. A No Impact Letter from NYSHPO has also been received.

Based on New York State Department of Conservation and U.S. Fish and Wildlife mapping, there are no environmental resource or critical habitat areas within the project site.

No other regulated environmental areas were identified within the vicinity of the project.

**D. TMDL Identification Requirements**

The site does not drain to a water body on the 303d list of impaired waters.

**E. Existing/Proposed Utility Lines, Easements, Water Supply and Sewage Treatment**

There are no utility lines that go directly through the project site. Electric service will be provided by National Grid. Gas service is not proposed to the project. A new water service will traverse through the property and tie into an existing main along Dryden Road (S.R. 366). Sanitary service to the individual units will be provided via a new network of privately owned/maintained sewers to be constructed. Treatment of waste from the project will take place at the Ithaca WWTP.

Developed peak discharges from the 10 and 100-year storm events from Study Points 1 and 2 are reduced from existing discharges currently encountered at those locations. Discharge from Study Point 3 leaves the site through the control structure of the proposed SWM facility located along Mt. Pleasant Road. Although, as confirmed by the contents of this report, there is a decrease in peak runoff discharges to Study Point 3, there is a redirection of what is currently sheet flow into the proposed SWM facility. As an aggregate to Drainage Area 3, the engineered outlet structure does attenuate flows. However, at the point that the facility will be tied into the Town of Dryden's existing storm sewer along the south side of Mt. Pleasant Rd, peak rate of runoff will be increased under developed conditions.

To address this increase a capacity analysis of a portion of the existing system was completed. Three existing catch basins and three segments of existing 30" corrugated plastic pipe located along the south side of Mt. Pleasant Road were reviewed and analyzed. An analysis of existing conditions was completed and existing capacity of the three segments of pipe calculated using Manning's equation method. See Appendix P for details and assumptions utilized in the analysis of the existing storm sewer. The existing 30" CPP storm sewer has a full flow capacity of 65.23 CFS. Under existing conditions approximately 8.63 CFS flows through this system. For developed conditions an additional 1.32 CFS will leave the control structure and enter the new storm structure connecting to the existing system along Mt. Pleasant Road. The availability capacity of the storm sewer exceeds the proposed 25-year discharge and, therefore, no adverse impacts are expected from this development's site storm water management outfall.

#### F. Soil Identification, Description and Hydrological Soil Group

The NRCS Soil Survey map shows that the study area contains six soil series. four of these soil series, namely Alluvial land, Howard gravelly loam, Hudson silty clay loam and Ovid silty clay loam are listed as moderately well drained soils to well drained soils series. Rhinebeck silt loam and Darien Gravelly silt loam are somewhat poorly drained soils series.

Additional Geotech testing and evaluation has been completed and is included in this report. The soils in the area of the development were found to drain very well; however, bedrock was identified at depths ranging from approximately 7 feet to 3 feet deep. The infiltration basin has been designed to maintain a minimum separation of 3 feet from the bedrock elevations. It is expected that additional geotechnical information will be collected in the spring to confirm the infiltration rates in the southern portion of the basin.

#### G. Protection and Enhancement of Natural Resources

The site plan was developed to utilize the natural hydrology of the site, preserve natural resources and reduce impervious cover.

As part of the planning process various strategies have been implemented to minimize runoff and maintain pre-construction hydrology. All reasonable opportunities as specified by the NYSDEC Stormwater Design manual have been evaluated.

In order to maintain the existing conditions to the greatest extent possible, the site will use soil restorative measures after final grading. As specified by the NYSDEC manual, a minimum six (6) inches of topsoil with aeration is required to restore the soil to the pre-developed condition. Full soil restoration is specified in areas of existing impervious or heavy construction traffic areas.

#### H. Acreage and Location of Proposed Impervious Areas

The proposed development will add approximately 7.56 acres of impervious cover due to the buildings, parking and an access road.

#### I. Initial Water Quality Volume

A site plan of the development with impervious areas and sub-catchments defined has been developed taking the natural resource preservation into consideration. The initial water quality volume (WQv) is calculated as 0.596 acre feet or 25,692 SF.

#### J. Required Runoff Reduction

Based on the Hydrologic conditions of the site and initial water quality volume, the NYSDEC requires a reduction in runoff volume by using specified Green Infrastructure Techniques and SMPs. Infiltration is proposed to meet 100% of the required RRv. The minimum RRv that must be provided on the site is 0.174 acre feet or 7,579 SF.

### 4. Post-Construction Storm Water Pollution Prevention Plan

#### A. Proposed Development and SWPPP Description

A sizable infiltration basin is proposed to serve the stormwater attenuation needs for the project. Pretreatment will be provided to promote significant pretreatment of the stormwater and to assist with stormwater detention requirements. The flow from the forebay is directed into the infiltration basin via stone berm filter, with overflow bypassing the infiltration basin and discharging toward the wetland. During the 100 year storm event, there is only minimal flow exiting the stormwater system and it has been sized to meet all RRv, WQv, and flood control requirements.

#### B. Proposed Stormwater Management Plan and Drainage Areas

A hydrologic model of the project site was generated using the TR-20 Method along with PondPack by Bentley Systems that creates a synthetic hydrograph using the U.S Natural Resources Conservation Service (NRCS), previously known as the Soil Conservation Service (SCS) Unit Hydrograph Method. The unit hydrograph was developed based on historically measured data that was measured in the field for storm systems that normally occur in this region of the United States known as "Type II Storms". The proposed development was designed to maintain or reduce the existing runoff rates to the aforementioned study points.

**Proposed Conditions**

<b>Watershed</b>	<b>Curve Number</b>	<b>Area (acres)</b>	<b>Tc (hours)</b>
DA-1 POST	90	2.40	0.10
DA-1 BYPASS POST	85	5.46	0.25
DA-1 OFFSITE POST	85	5.05	0.50
DA-2 POST	90	7.86	0.10
DA-2 BYPASS POST	78	0.16	0.167
DA-2 OFFSITE POST	78	108.04	0.60
DA-3 POST	90	1.59	0.083
DA-3 BYPASS POST	85	2.88	0.20
DA-3 OFFSITE POST	78	6.13	0.40

**Provided Runoff Reduction**

It was determined that the large infiltration basin within DA 2 could provide RRv for the entire development. Pretreatment methods will need to be provided to 100% of the WQv prior to that drainage entering the facility. The site layout and grading were designed to transfer the greatest amount of stormwater runoff possible to the infiltration basin. Because the infiltration basin holding volume exceeds the required runoff reduction volume, the requirement is met and one hundred percent (100%) runoff reduction is achieved.

Infiltration Holding Volume = 0.91 ac-ft or 39,500 cf at elev: 967.5  
>> RRv<sub>.28</sub> = 0.170 ac-ft or 7,405 cu-ft

**A. Final Water Quality Treatment Volume**

The Water Quality volume has been reduced by the runoff reduction techniques discussed above; therefore, no additional facilities are required for water quality treatment purposes.

**B. Channel Protection**

To protect the surrounding areas from erosion of conveyance, stream channel protection must be provided. Channel Protection calculations are based on the ability of the system to handle the runoff volume of the 1-year storm event. As the facility holding volume is greater than runoff from the 1-year storm event, reduction of the entire channel protection volume is achieved.

Permanent outlet protection and turf reinforcement matting are proposed on-site to prevent erosion from occurring at critical areas of the stormwater management system.

C. Overbank and Extreme Flood Control Analysis Results

Complete printouts from the hydrologic analysis are provided in the appendices. The following tables summarize the results from that analysis.

**Summary of Stormwater Runoff Rates at Study Points (cfs)**

Study Point	1 Year Storm Event			10 Year – Overbank Flood			100 Year – Extreme Flood		
	PRE	POST	CHANGE	PRE	POST	CHANGE	PRE	POST	CHANGE
St. Pt. 1	6.98	9.39	34.5%	26.86	25.39	-5.5%	54.19	45.58	-15.9%
St. Pt. 2	34.49	9.44	-72.6%	144.52	141.18	-2.3%	298.68	295.31	-1.1%
St. Pt. 3	5.16	5.61	-33%	21.23	17.76	-16.3%	44.06	36.19	-17.9%
Entire Site	46.63	24.44	47.6%	192.61	184.33	-4.3%	396.93	377.08	-5%

As required by the NYSDEC Storm Water Manual for infiltration greater than five (5) inches per hour, pretreatment measures will be utilized to provide minimum required volumes pending outcome of final infiltration testing.

D. Maintenance Agreement

Detrimental impacts to the environment may occur if the stormwater management system is not maintained to perform as it was designed. For this reason, it is important to ensure that these facilities are maintained properly and inspected at regular time intervals. A binding, legal maintenance agreement will be executed between the Town of Dryden and Trinitas Ventures to reflect that the permanent drainage structures will be maintained by Trinitas Ventures or its assignees following project completion. Certain aspects of the system will be inspected and/or cleaned in monthly, annually, and in 5-year increments. See the appendices for the Post Construction Operations and Maintenance Manual.

5. During Construction Storm Water Pollution Prevention Plan

A. Acreage of Disturbed Area

The development of the proposed residential building will disturb 15.7 acres. Disturbance includes clearing and grubbing, excavation, and construction of the proposed improvements as indicated on the engineering drawings.

B. Duration of Construction Activity

It is anticipated that the construction of this project will occur between June 1, 2019 and November 30, 2020.

C. Pollution Prevention Measures

During all phases of earth disturbance, the pollution prevention measures as stipulated in the SWPPP will be followed. Pollution prevention measures such as stockpile stabilization

with cover, dust control, and temporary seeding will be installed to minimize debris and litter from traveling offsite.

Regular maintenance of the sediment and erosion control structures shall be performed. The contractor shall be responsible for the proper removal and cleaning of the affected areas in the event that sediment is conveyed off-site.

#### D. SWPPP Implementation and Inspection

The scope of the SWPPP will be an ongoing process that will include a sequenced construction approach to stormwater management and erosion & sediment control as indicated on the enclosed plans. The SWPPP and amendments to the SWPPP seek to maintain water quality during the construction phase of the project. The purpose of the SWPPP is to ensure that the stormwater management goals of the project design are met during construction activities and prior to final stabilization of disturbed areas.

Trinitas Ventures  
Attn. Kimberly Hansen  
201 Main St  
Lafayette, IN 47901  
Phone: (765) 464-2800

Trinitas Ventures will act as the manager of the entire project with a qualified consultant responsible for SWPPP inspection. The qualified consultant shall provide certifications at regular intervals during construction activities and a permanent certification upon completion of the project.

Site inspections will be completed by a qualified person every seven days. Typical items of inspection will be:

1. Placement of mulch and seeding
2. Sediment traps & basins, silt fences and other erosion and sediment control devices
3. Visible signs of erosion
4. Identify potential pollutants entering or exiting site, such as turbidity in receiving or exiting waters, and signs of mud or dirt transported from the site onto the public road.

#### E. Construction Site Log Book

A Construction Site Log Book with inspection forms are included in Appendices and shall be updated and amended as the project progresses.

#### F. Construction Sequence

A construction sequence has been included in the attached engineering plans.

**APPENDIX A**  
**Location and Soils Mapping**

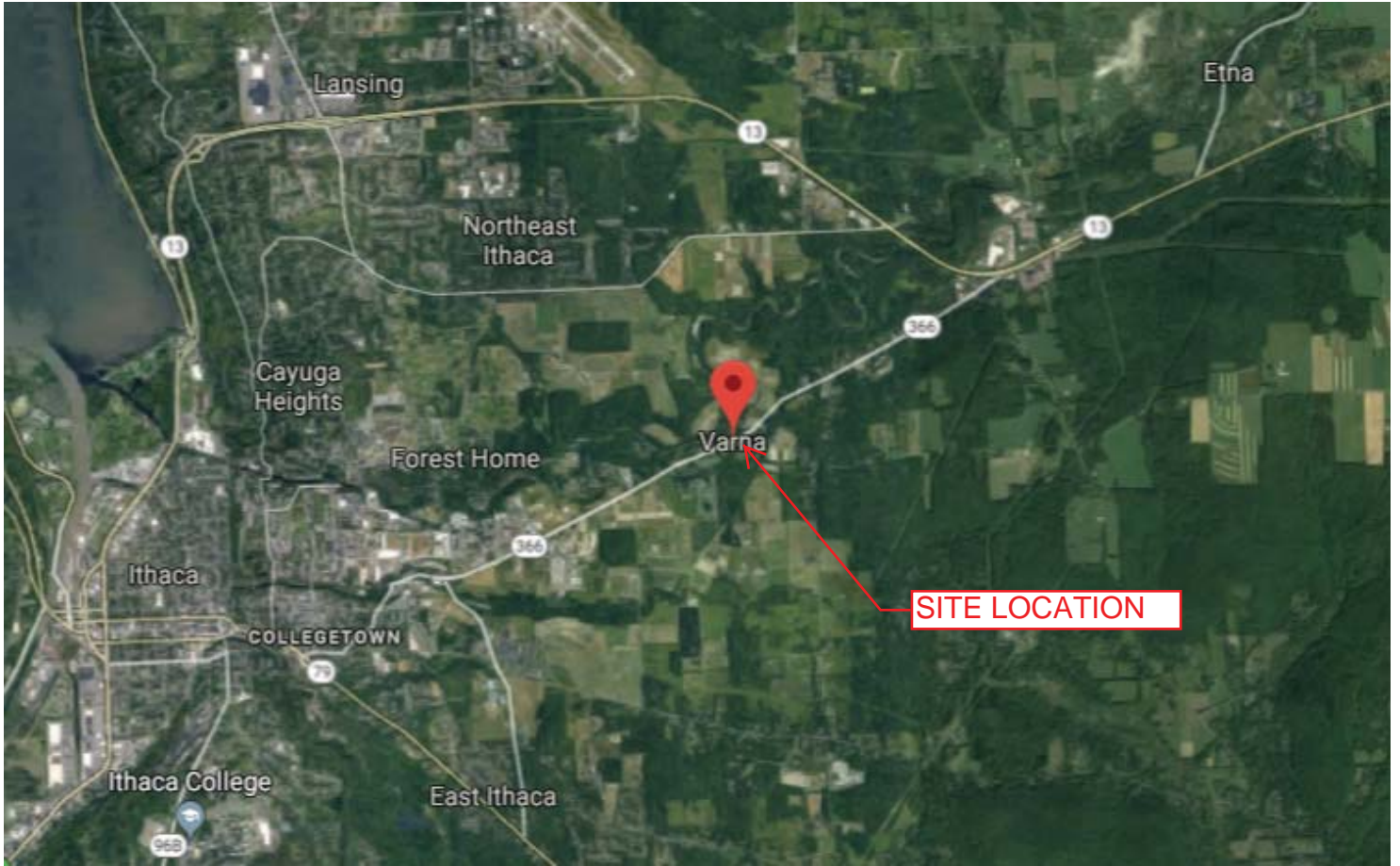

**SITE LOCATION**



**HUNT**  
 ENGINEERS/ARCHITECTS/SURVEYORS

4 COMMERCIAL ST.  
 SUITE 300  
 ROCHESTER, NY 14614  
 585 • 327 • 7950  
 FAX • 327 • 7949

HORSEHEADS, NY      ROCHESTER, NY      TOWANDA, PA

**LOCATION MAP**

TRINITAS VENTURES  
 TOWNHOMES AT DRYDEN  
 366 DRYDEN ROAD, ITHACA, NY 14850

**1**  
 3177.001



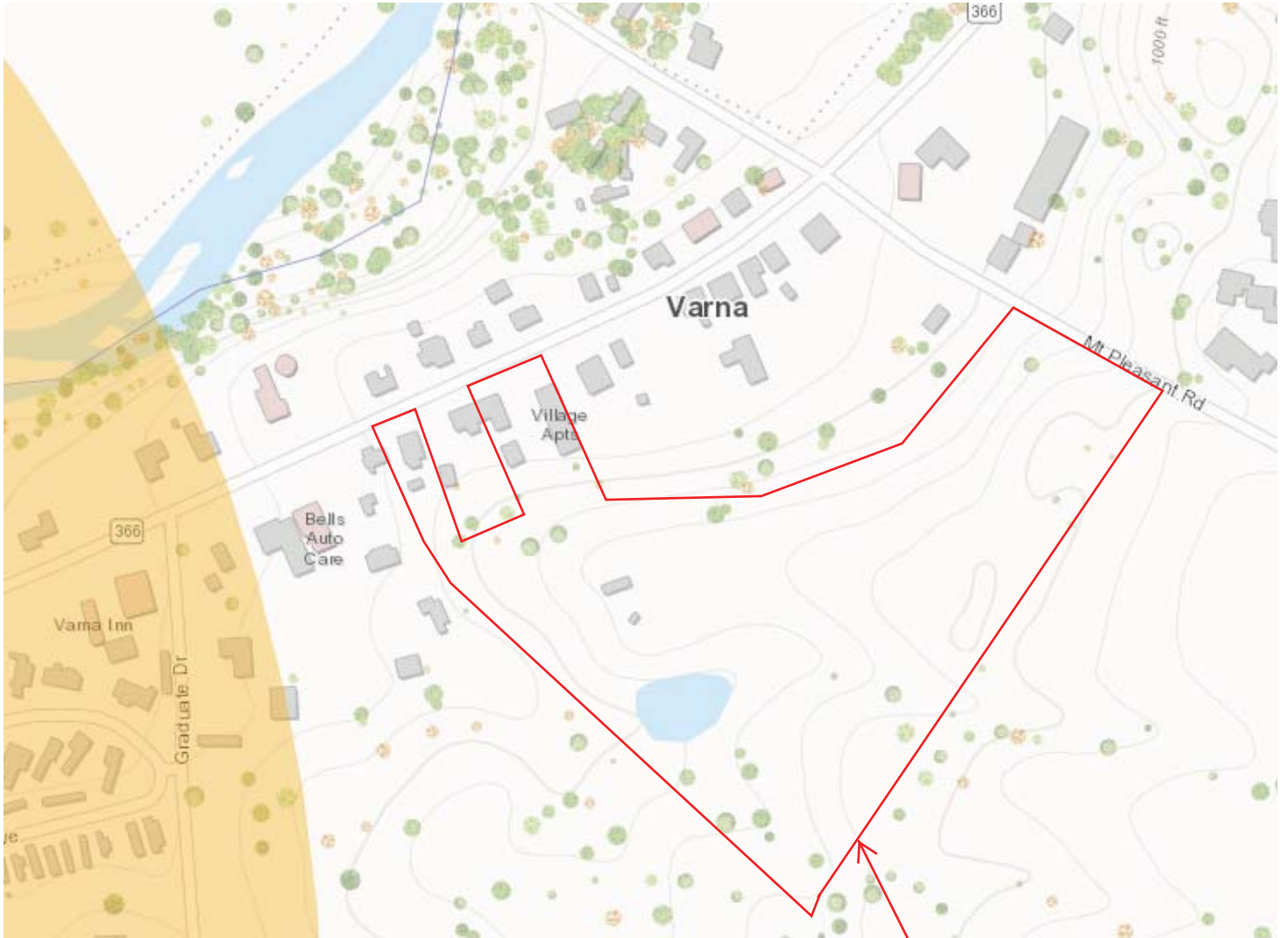

PROJECT SITE



**HUNT**  
 ENGINEERS/ARCHITECTS/SURVEYORS

4 COMMERCIAL ST.  
 SUITE 300  
 ROCHESTER, NY 14614  
 585 • 327 • 7950  
 FAX • 327 • 7949

HORSEHEADS, NY      ROCHESTER, NY      TOWANDA, PA

**ENVIRONMENTAL MAP**

TRINITAS VENTURES  
 TOWNHOMES AT DRYDEN  
 366 DRYDEN ROAD, ITHACA, NY 14850

**2**  
 3177.001



Map unit symbol	Map unit name	Rating	Acres in AOI	Percent of AOI
Ab	Alluvial land	A/D	1.8	11.5%
DgB	Darien gravelly silt loam, 2 to 8 percent slopes	C/D	2.8	17.9%
HdA	Howard gravelly loam, 0 to 5 percent slopes	A	1.4	9.1%
HsD3	Hudson silty clay loam, 12 to 20 percent slopes, eroded	C/D	5.2	32.9%
OcC3	Ovid silty clay loam, 6 to 12 percent slopes eroded	C/D	1.8	11.3%
RkB	Rhinebeck silt loam, 2 to 6 percent slopes	C/D	2.7	17.3%
<b>Totals for Area of Interest</b>			<b>15.9</b>	<b>100.0%</b>



**HUNT** 4 COMMERCIAL ST.  
 SUITE 300  
 ROCHESTER, NY 14614  
 585 • 327 • 7950  
 ENGINEERS/ARCHITECTS/SURVEYORS FAX • 327 • 7949

HORSEHEADS, NY      ROCHESTER, NY      TOWANDA, PA

**SOILS MAP**

TRINITAS VENTURES  
 TOWNHOMES AT DRYDEN  
 366 DRYDEN ROAD, ITHACA, NY 14850

**3**  
3177.001

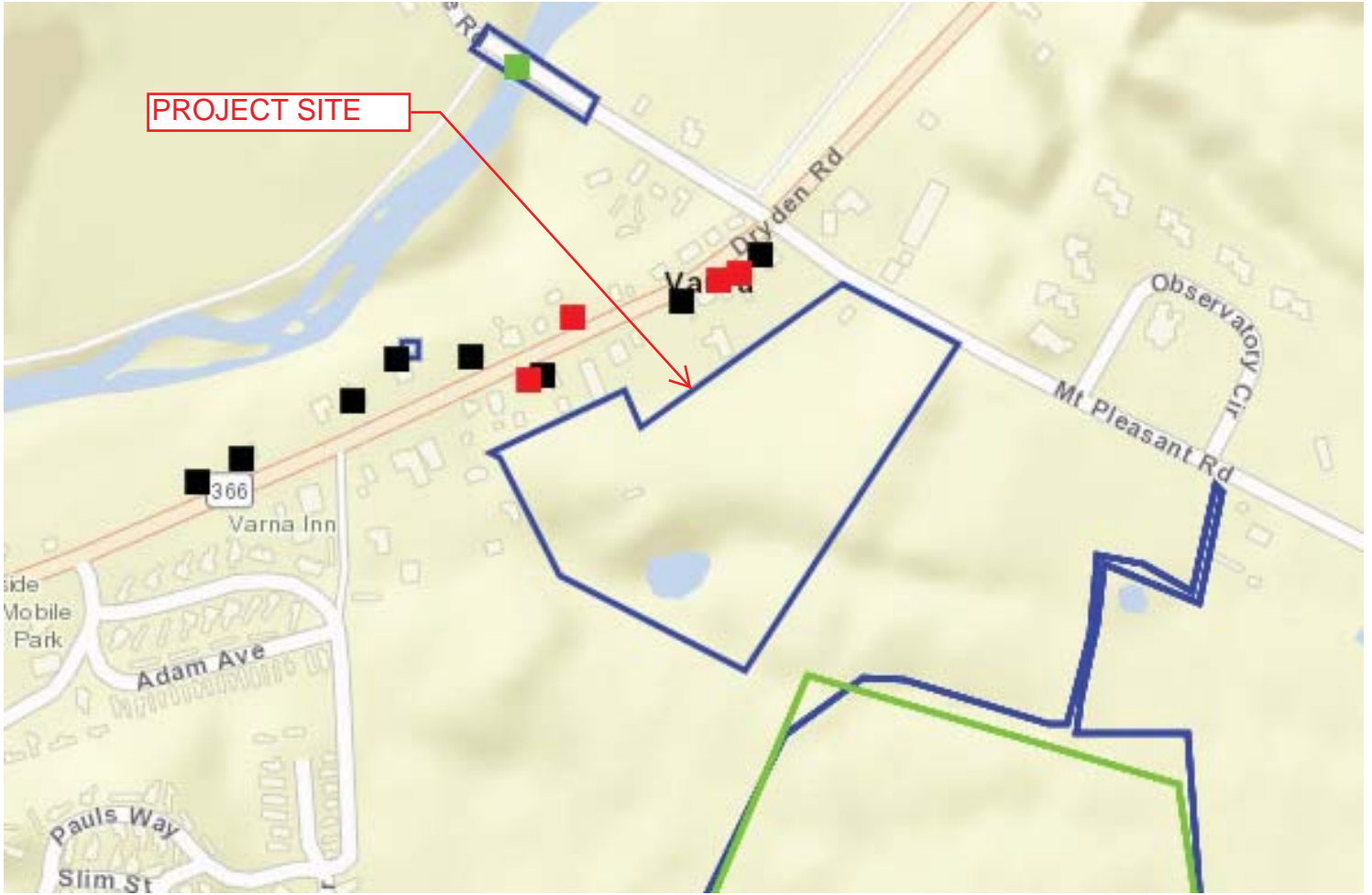

4 COMMERCIAL ST.  
 SUITE 300  
 ROCHESTER, NY 14614  
 585 • 327 • 7950  
 FAX • 327 • 7949

HORSEHEADS, NY

ROCHESTER, NY

TOWANDA, PA

## SHPO MAP

TRINITAS VENTURES  
 TOWNHOMES AT DRYDEN  
 366 DRYDEN ROAD, ITHACA, NY 14850

4  
 3177.001





PROJECT SITE

**Wetlands**

- Estuarine and Marine Deepwater
- Estuarine and Marine Wetland
- Freshwater Emergent Wetland
- Freshwater Forested/Shrub Wetland
- Freshwater Pond
- Lake
- Other
- Riverine



4 COMMERCIAL ST.  
 SUITE 300  
 ROCHESTER, NY 14614  
 585 • 327 • 7950  
 FAX • 327 • 7949

HORSEHEADS, NY      ROCHESTER, NY      TOWANDA, PA

**NATIONAL WETLANDS MAP**

TRINITAS VENTURES  
 TOWNHOMES AT DRYDEN  
 366 DRYDEN ROAD, ITHACA, NY 14850

**5**  
3177.001

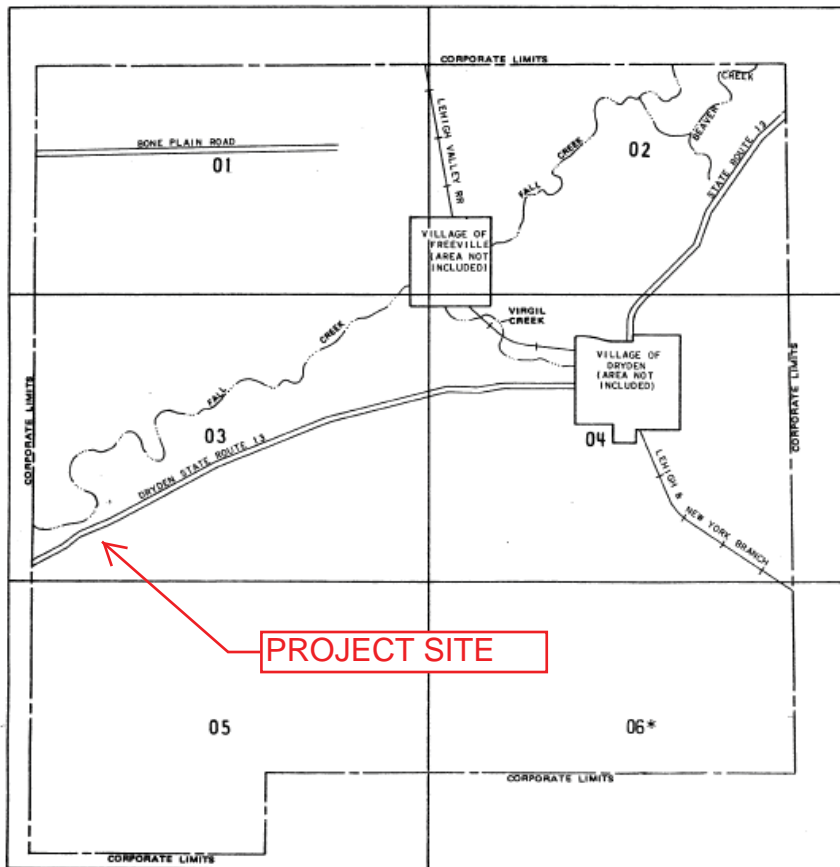

\*PAGE NOT PRINTED - AREA IN ZONE C



**KEY TO SYMBOLS**

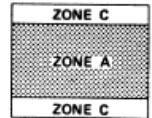

**ZONE DESIGNATIONS\***

Base Flood Elevation Line with elevation in feet ~ 513 ~  
 Base Flood Elevation where uniform within zone (EL 587)  
 Elevation Reference Mark RM7<sub>2</sub>  
 River Mile M1.5

**\*EXPLANATION OF ZONE DESIGNATIONS**

A flood insurance map depicts the zone designations for a community, according to areas of designated flood hazards. The zone designations used by FEMA are:

Zone	Explanation
A	Areas of 100 year flood, base flood elevations and flood hazard factors not determined.
AD	Areas of 100-year shallow flooding, flood depth 1 to 3 feet; product of flood depth (feet) and velocity (feet per second) less than 15.
AO	Areas of 100 year shallow flooding where depths are between one (1) and three (3) feet, base flood elevations are shown, but no flood hazard factors are determined.
A1-A30	Areas of 100 year flood, base flood elevations and flood hazard factors determined.
A99	Areas of 100 year flood to be protected by a flood protection system under construction, base flood elevations and flood hazard factors not determined.
B	Areas between limits of 100-year flood and 500-year flood, areas of 100-year shallow flooding where depths less than 1 foot.
C	Areas outside 500 year flood.
D	Areas of undetermined, but possible, flood hazards.
V	Areas of 100 year coastal flood with velocity (wave action); base flood elevations and flood hazard factors not determined.
V1-V30	Areas of 100-year coastal flood with velocity (wave action); base flood elevations and flood hazard factors determined.

**NOTES TO USER**

Certain areas not in the special flood hazard areas (zones A and V) may be protected by Res. control structures.  
 This map is for flood insurance purposes only, it does not necessarily show all areas subject to flooding in the community or all geomorphic features outside special flood hazard areas.  
 Refer to the FLOOD INSURANCE RATE MAP EFFECTIVE date shown on this map to determine when actual rates apply to situations in the zones where structures or depths have been established.  
 To determine if flood insurance is available in this community, contact your insurance agent, or call the National Flood Insurance Program, at 800-638-6620.  
 INITIAL IDENTIFICATION JULY 19, 1974  
 FLOOD HAZARD BOUNDARY MAP REVISIONS JULY 2, 1976  
 FLOOD INSURANCE RATE MAP EFFECTIVE MAY 16, 1985  
 FLOOD INSURANCE RATE MAP REVISIONS

federal emergency management agency



**FIRM**  
**FLOOD INSURANCE RATE MAP 01-06**  
**MAP INDEX**  
**TOWN OF DRYDEN, NY**  
**(TOMPKINS CO.)**

**COMMUNITY NUMBER 380846 B**



**HUNT** ENGINEERS/ARCHITECTS/SURVEYORS  
 4 COMMERCIAL ST.  
 SUITE 300  
 ROCHESTER, NY 14614  
 585 • 327 • 7950  
 FAX • 327 • 7949

HORSEHEADS, NY      ROCHESTER, NY      TOWANDA, PA

**FEMA FLOOD MAP**

TRINITAS VENTURES  
 TOWNHOMES AT DRYDEN  
 366 DRYDEN ROAD, ITHACA, NY 14850

**6**  
3177.001

**APPENDIX B**

**Notice of Intent (NOI) and Notice of Termination (NOT)**

**New York State Department of Environmental Conservation  
Division of Water  
625 Broadway, 4th Floor  
Albany, New York 12233-3505**

\*(NOTE: Submit completed form to address above)\*

**NOTICE OF TERMINATION for Storm Water Discharges Authorized  
under the SPDES General Permit for Construction Activity**

**Please indicate your permit identification number:** NYR \_\_\_\_\_

**I. Owner or Operator Information**

1. Owner/Operator Name:

2. Street Address:

3. City/State/Zip:

4. Contact Person:

4a. Telephone:

4b. Contact Person E-Mail:

**II. Project Site Information**

5. Project/Site Name:

6. Street Address:

7. City/Zip:

8. County:

**III. Reason for Termination**

9a.  All disturbed areas have achieved final stabilization in accordance with the general permit and SWPPP. \*Date final stabilization completed (month/year): \_\_\_\_\_

9b.  Permit coverage has been transferred to new owner/operator. Indicate new owner/operator's permit identification number: NYR \_\_\_\_\_

(Note: Permit coverage can not be terminated by owner identified in I.1. above until new owner/operator obtains coverage under the general permit)

9c.  Other (Explain on Page 2)

**IV. Final Site Information:**

10a. Did this construction activity require the development of a SWPPP that includes post-construction stormwater management practices?  yes  no (If no, go to question 10f.)

10b. Have all post-construction stormwater management practices included in the final SWPPP been constructed?  yes  no (If no, explain on Page 2)

10c. Identify the entity responsible for long-term operation and maintenance of practice(s)?

\_\_\_\_\_

**NOTICE OF TERMINATION for Storm Water Discharges Authorized under the  
SPDES General Permit for Construction Activity - continued**

10d. Has the entity responsible for long-term operation and maintenance been given a copy of the operation and maintenance plan required by the general permit?     yes     no

10e. Indicate the method used to ensure long-term operation and maintenance of the post-construction stormwater management practice(s):

- Post-construction stormwater management practice(s) and any right-of-way(s) needed to maintain practice(s) have been deeded to the municipality.
- Executed maintenance agreement is in place with the municipality that will maintain the post-construction stormwater management practice(s).
- For post-construction stormwater management practices that are privately owned, a mechanism is in place that requires operation and maintenance of the practice(s) in accordance with the operation and maintenance plan, such as a deed covenant in the owner or operator's deed of record.
- For post-construction stormwater management practices that are owned by a public or private institution (e.g. school, university or hospital), government agency or authority, or public utility; policy and procedures are in place that ensures operation and maintenance of the practice(s) in accordance with the operation and maintenance plan.

10f. Provide the total area of impervious surface (i.e. roof, pavement, concrete, gravel, etc.) constructed within the disturbance area? \_\_\_\_\_  
(acres)

11. Is this project subject to the requirements of a regulated, traditional land use control MS4?     yes  
 no  
(If Yes, complete section VI - "MS4 Acceptance" statement)

**V. Additional Information/Explanation:**  
(Use this section to answer questions 9c. and 10b., if applicable)

**VI. MS4 Acceptance - MS4 Official (principal executive officer or ranking elected official) or Duly Authorized Representative** (Note: Not required when 9b. is checked -transfer of coverage)

I have determined that it is acceptable for the owner or operator of the construction project identified in question 5 to submit the Notice of Termination at this time.

Printed Name:

Title/Position:

Signature:

Date:



**NOTICE OF TERMINATION for Storm Water Discharges Authorized under the  
SPDES General Permit for Construction Activity - continued**

**VII. Qualified Inspector Certification - Final Stabilization:**

I hereby certify that all disturbed areas have achieved final stabilization as defined in the current version of the general permit, and that all temporary, structural erosion and sediment control measures have been removed. Furthermore, I understand that certifying false, incorrect or inaccurate information is a violation of the referenced permit and the laws of the State of New York and could subject me to criminal, civil and/or administrative proceedings.

Printed Name:

Title/Position:

Signature:

Date:

**VIII. Qualified Inspector Certification - Post-construction Stormwater Management Practice(s):**

I hereby certify that all post-construction stormwater management practices have been constructed in conformance with the SWPPP. Furthermore, I understand that certifying false, incorrect or inaccurate information is a violation of the referenced permit and the laws of the State of New York and could subject me to criminal, civil and/or administrative proceedings.

Printed Name:

Title/Position:

Signature:

Date:

**IX. Owner or Operator Certification**

I hereby certify that this document was prepared by me or under my direction or supervision. My determination, based upon my inquiry of the person(s) who managed the construction activity, or those persons directly responsible for gathering the information, is that the information provided in this document is true, accurate and complete. Furthermore, I understand that certifying false, incorrect or inaccurate information is a violation of the referenced permit and the laws of the State of New York and could subject me to criminal, civil and/or administrative proceedings.

Printed Name:

Title/Position:

Signature:

Date:

**APPENDIX C**

**MS4 - SWPPP ACCEPTANCE FORM**



Department of  
Environmental  
Conservation

NYS Department of Environmental Conservation  
Division of Water  
625 Broadway, 4th Floor  
Albany, New York 12233-3505

## MS4 Stormwater Pollution Prevention Plan (SWPPP) Acceptance Form

for

**Construction Activities Seeking Authorization Under SPDES General Permit**

\*(NOTE: Attach Completed Form to Notice Of Intent and Submit to Address Above)

### I. Project Owner/Operator Information

1. Owner/Operator Name:

2. Contact Person:

3. Street Address:

4. City/State/Zip:

### II. Project Site Information

5. Project/Site Name:

6. Street Address:

7. City/State/Zip:

### III. Stormwater Pollution Prevention Plan (SWPPP) Review and Acceptance Information

8. SWPPP Reviewed by:

9. Title/Position:

10. Date Final SWPPP Reviewed and Accepted:

### IV. Regulated MS4 Information

11. Name of MS4:

12. MS4 SPDES Permit Identification Number: NYR20A

13. Contact Person:

14. Street Address:

15. City/State/Zip:

16. Telephone Number:

**APPENDIX Q**  
**Selected Engineering Plans**

**MS4 SWPPP Acceptance Form - continued**

**V. Certification Statement - MS4 Official (principal executive officer or ranking elected official) or Duly Authorized Representative**

I hereby certify that the final Stormwater Pollution Prevention Plan (SWPPP) for the construction project identified in question 5 has been reviewed and meets the substantive requirements in the SPDES General Permit For Stormwater Discharges from Municipal Separate Storm Sewer Systems (MS4s).  
Note: The MS4, through the acceptance of the SWPPP, assumes no responsibility for the accuracy and adequacy of the design included in the SWPPP. In addition, review and acceptance of the SWPPP by the MS4 does not relieve the owner/operator or their SWPPP preparer of responsibility or liability for errors or omissions in the plan.

Printed Name:

Title/Position:

Signature:

Date:

**VI. Additional Information**

## **APPENDIX D**

### **Contractor's Certification**

**Contractor Certification Statement**

I hereby certify that I understand and agree to comply with the terms and conditions of the SWPPP dated October 2018 for the *Trinitas Ventures Townhomes at Dryden* project located in the *Town of Dryden, Tompkins County, NY* and agree to implement any corrective actions identified by the qualified inspector during a site inspection. I also understand that the owner or operator must comply with the terms and conditions of the New York State Pollutant Discharge Elimination System ("SPDES") general permit for stormwater discharges from construction activities and that it is unlawful for any person to cause or contribute to a violation of water quality standards. Furthermore, I understand that certifying false, incorrect or inaccurate information is a violation of the referenced permit and the laws of the State of New York and could subject me to criminal, civil and/or administrative proceedings.

Elements of the SWPPP that are my responsibility include:

---

---

---

---

---

The name and title of the trained individual responsible for the SWPPP implementation is:

---

Signature \_\_\_\_\_

Date \_\_\_\_\_

Printed Name & Title \_\_\_\_\_

Company Name \_\_\_\_\_

Address \_\_\_\_\_

---

Phone \_\_\_\_\_

## **APPENDIX E**

### **Site Planning and Green Infrastructure Matrices**



# Hunt Engineers, Architects, Surveyors

TOWNHOMES AT DRYDEN

TOWN OF DRYDEN, NY

Design By: JFS

Checked By:

Date: 9/28/2018

Revised:

## Site Planning Evaluation

Group	Practice	Implemented	Reason Practice is Infeasible for Site
<b>Preservation of Natural Resources</b>	Preservation of Undisturbed Areas	Yes	Design works around previously undisturbed areas and environmentally sensitive areas to the extent practical.
	Preservation of Buffers	Yes	A 50 foot buffer around the wetland will be preserved to the extent practical.
	Reduction of Clearing and Grading	Yes	Vegetation around the project's perimeter is to be protected and to remain where practical.
	Locating Development in Less Sensitive Areas	Yes	Within the limits of the property certain environmental features are to be preserved and even improved upon. The project meets the intended use of the site per Town zoning.
	Open Space Design	No	Site layout was designed with the minimum amounts of impervious cover while still serving community's needs
	Soil Restoration	Yes	Fill locations will use soil from on-site cut locations to allow soil conditions to remain similar to pre-development conditions, See plans for notes on aeration and deep tilling restoration technique requirements
<b>Reduction of Impervious Cover</b>	Roadway Reduction	Yes	Access road is the minimum width permitted by Town Code.
	Sidewalk Reduction	No	Sidewalk Layout was based on access for residents.
	Driveway Reduction	Yes	The driveway was designed to be as compact as possible and provide the required fire access.
	Cul-de-sac Reduction	No	No cul-de-sac was included on the site
	Building Footprint Reduction	No	Building layout was based on the needs of the facility. Multi-story buildings allow a reduced footprint to the site.
	Parking Reduction	Yes	Parking was provided based on the minimum amount necessary to service the project and meet Town Code.

# Hunt Engineers, Architects, Surveyors

TOWNHOMES AT DRYDEN

TOWN OF DRYDEN, NY

Design By: JFS

Checked By:

Date: 9/28/2018

Revised:

## Water Quality Techniques

Group	Practice	Implemented	Reason Practice is Infeasible for Site
Green Infrastructure	Conservation of Natural Areas	No	While the wetland area has been conserved, it was not included in the GI calculations.
	Sheetflow to Riparian Buffers or Filter Strips	No	Riparian buffers infeasible due to site size
	Vegetated Open Swale	No	N/A no new swales proposed
	Tree Planting/Tree Box	No	Trees will be planted but not included in calculations
	Disconnection of Rooftop Runoff	No	N/A
	Stream Daylighting for Redevelopment Projects	No	No buried streams onsite
	Rain Garden	No	Rain gardens will be considered for use with final design.
	Green Roof	No	Not appropriate for applications of this type and scale.
	Stormwater Planter	No	Required size and maintenance is not economically feasible for site.
	Rain Tank Cistern	No	Required size and maintenance is not economically feasible for site.
	Porous Pavement	No	Potentially feasible, but not preferred to maintenance requirements and installation costs/difficulties.
Standard Management Practices	yes	Infiltration basins and underground infiltration systems will be used to manage stormwater.	

**APPENDIX F**  
**Precipitation Data**



**POINT PRECIPITATION FREQUENCY ESTIMATES**

Sanja Perica, Sandra Pavlovic, Michael St. Laurent, Carl Trypaluk, Dale Unruh, Orlan Wilhite

NOAA, National Weather Service, Silver Spring, Maryland

[PF\\_tabular](#) | [PF\\_graphical](#) | [Maps & aerials](#)

**PF tabular**

<b>PDS-based point precipitation frequency estimates with 90% confidence intervals (in inches)<sup>1</sup></b>										
Duration	Average recurrence interval (years)									
	1	2	5	10	25	50	100	200	500	1000
<b>5-min</b>	<b>0.296</b> (0.240-0.362)	<b>0.362</b> (0.292-0.442)	<b>0.469</b> (0.378-0.576)	<b>0.558</b> (0.446-0.689)	<b>0.681</b> (0.524-0.885)	<b>0.775</b> (0.582-1.03)	<b>0.869</b> (0.632-1.21)	<b>0.994</b> (0.676-1.41)	<b>1.16</b> (0.753-1.71)	<b>1.28</b> (0.811-1.94)
<b>10-min</b>	<b>0.420</b> (0.340-0.512)	<b>0.513</b> (0.414-0.626)	<b>0.665</b> (0.535-0.815)	<b>0.791</b> (0.632-0.976)	<b>0.964</b> (0.742-1.25)	<b>1.10</b> (0.825-1.46)	<b>1.23</b> (0.895-1.71)	<b>1.41</b> (0.958-2.00)	<b>1.64</b> (1.07-2.42)	<b>1.82</b> (1.15-2.75)
<b>15-min</b>	<b>0.494</b> (0.399-0.603)	<b>0.603</b> (0.487-0.737)	<b>0.782</b> (0.629-0.959)	<b>0.930</b> (0.744-1.15)	<b>1.13</b> (0.873-1.47)	<b>1.29</b> (0.971-1.72)	<b>1.45</b> (1.05-2.01)	<b>1.66</b> (1.13-2.36)	<b>1.93</b> (1.25-2.85)	<b>2.14</b> (1.35-3.23)
<b>30-min</b>	<b>0.673</b> (0.544-0.821)	<b>0.821</b> (0.663-1.00)	<b>1.06</b> (0.856-1.30)	<b>1.26</b> (1.01-1.56)	<b>1.54</b> (1.19-2.00)	<b>1.75</b> (1.32-2.34)	<b>1.97</b> (1.43-2.74)	<b>2.25</b> (1.53-3.20)	<b>2.62</b> (1.71-3.87)	<b>2.90</b> (1.84-4.39)
<b>60-min</b>	<b>0.852</b> (0.689-1.04)	<b>1.04</b> (0.839-1.27)	<b>1.34</b> (1.08-1.65)	<b>1.60</b> (1.28-1.97)	<b>1.95</b> (1.50-2.53)	<b>2.22</b> (1.67-2.95)	<b>2.49</b> (1.81-3.46)	<b>2.84</b> (1.93-4.04)	<b>3.31</b> (2.15-4.90)	<b>3.67</b> (2.32-5.54)
<b>2-hr</b>	<b>1.06</b> (0.865-1.29)	<b>1.27</b> (1.03-1.54)	<b>1.61</b> (1.30-1.96)	<b>1.89</b> (1.52-2.32)	<b>2.28</b> (1.76-2.94)	<b>2.57</b> (1.95-3.41)	<b>2.87</b> (2.10-3.98)	<b>3.29</b> (2.25-4.65)	<b>3.84</b> (2.51-5.64)	<b>4.26</b> (2.71-6.40)
<b>3-hr</b>	<b>1.20</b> (0.978-1.45)	<b>1.42</b> (1.16-1.72)	<b>1.79</b> (1.45-2.17)	<b>2.09</b> (1.69-2.56)	<b>2.51</b> (1.95-3.24)	<b>2.84</b> (2.15-3.75)	<b>3.16</b> (2.32-4.37)	<b>3.63</b> (2.48-5.10)	<b>4.24</b> (2.77-6.21)	<b>4.71</b> (3.00-7.04)
<b>6-hr</b>	<b>1.45</b> (1.19-1.74)	<b>1.72</b> (1.42-2.07)	<b>2.18</b> (1.78-2.63)	<b>2.56</b> (2.08-3.10)	<b>3.08</b> (2.41-3.94)	<b>3.48</b> (2.66-4.57)	<b>3.88</b> (2.87-5.34)	<b>4.47</b> (3.07-6.25)	<b>5.26</b> (3.45-7.64)	<b>5.85</b> (3.73-8.69)
<b>12-hr</b>	<b>1.72</b> (1.42-2.05)	<b>2.09</b> (1.73-2.49)	<b>2.69</b> (2.22-3.22)	<b>3.19</b> (2.61-3.85)	<b>3.88</b> (3.05-4.94)	<b>4.41</b> (3.39-5.76)	<b>4.94</b> (3.68-6.76)	<b>5.72</b> (3.94-7.95)	<b>6.75</b> (4.44-9.75)	<b>7.53</b> (4.82-11.1)
<b>24-hr</b>	<b>2.01</b> (1.68-2.38)	<b>2.47</b> (2.06-2.93)	<b>3.22</b> (2.67-3.83)	<b>3.84</b> (3.16-4.60)	<b>4.69</b> (3.72-5.94)	<b>5.35</b> (4.14-6.95)	<b>6.01</b> (4.49-8.17)	<b>6.97</b> (4.83-9.62)	<b>8.24</b> (5.44-11.8)	<b>9.20</b> (5.91-13.5)
<b>2-day</b>	<b>2.33</b> (1.95-2.74)	<b>2.84</b> (2.38-3.35)	<b>3.69</b> (3.07-4.36)	<b>4.38</b> (3.63-5.21)	<b>5.34</b> (4.26-6.71)	<b>6.09</b> (4.73-7.85)	<b>6.83</b> (5.13-9.22)	<b>7.91</b> (5.50-10.8)	<b>9.35</b> (6.19-13.3)	<b>10.4</b> (6.72-15.2)
<b>3-day</b>	<b>2.56</b> (2.15-2.99)	<b>3.10</b> (2.61-3.64)	<b>3.99</b> (3.35-4.70)	<b>4.74</b> (3.94-5.61)	<b>5.76</b> (4.60-7.20)	<b>6.54</b> (5.10-8.40)	<b>7.33</b> (5.52-9.86)	<b>8.49</b> (5.91-11.6)	<b>10.0</b> (6.65-14.2)	<b>11.2</b> (7.21-16.2)
<b>4-day</b>	<b>2.75</b> (2.32-3.21)	<b>3.32</b> (2.80-3.88)	<b>4.25</b> (3.57-4.99)	<b>5.02</b> (4.18-5.93)	<b>6.08</b> (4.87-7.58)	<b>6.90</b> (5.39-8.83)	<b>7.71</b> (5.82-10.3)	<b>8.91</b> (6.22-12.1)	<b>10.5</b> (6.98-14.9)	<b>11.7</b> (7.56-16.9)
<b>7-day</b>	<b>3.29</b> (2.80-3.82)	<b>3.89</b> (3.30-4.53)	<b>4.88</b> (4.12-5.70)	<b>5.70</b> (4.77-6.69)	<b>6.82</b> (5.49-8.44)	<b>7.69</b> (6.03-9.76)	<b>8.56</b> (6.46-11.4)	<b>9.78</b> (6.86-13.2)	<b>11.4</b> (7.61-16.0)	<b>12.6</b> (8.17-18.2)
<b>10-day</b>	<b>3.83</b> (3.26-4.43)	<b>4.45</b> (3.79-5.16)	<b>5.47</b> (4.64-6.37)	<b>6.32</b> (5.31-7.40)	<b>7.48</b> (6.03-9.20)	<b>8.38</b> (6.58-10.6)	<b>9.28</b> (7.00-12.2)	<b>10.5</b> (7.37-14.1)	<b>12.1</b> (8.07-16.9)	<b>13.3</b> (8.60-19.0)
<b>20-day</b>	<b>5.51</b> (4.73-6.34)	<b>6.19</b> (5.30-7.12)	<b>7.30</b> (6.22-8.43)	<b>8.22</b> (6.95-9.55)	<b>9.48</b> (7.67-11.5)	<b>10.5</b> (8.22-13.0)	<b>11.4</b> (8.59-14.7)	<b>12.5</b> (8.85-16.7)	<b>13.9</b> (9.38-19.4)	<b>15.0</b> (9.77-21.4)
<b>30-day</b>	<b>6.93</b> (5.97-7.93)	<b>7.66</b> (6.59-8.78)	<b>8.85</b> (7.58-10.2)	<b>9.84</b> (8.36-11.4)	<b>11.2</b> (9.09-13.5)	<b>12.2</b> (9.64-15.1)	<b>13.3</b> (9.98-16.9)	<b>14.3</b> (10.2-19.0)	<b>15.7</b> (10.6-21.6)	<b>16.7</b> (10.9-23.6)
<b>45-day</b>	<b>8.69</b> (7.52-9.91)	<b>9.50</b> (8.20-10.8)	<b>10.8</b> (9.30-12.4)	<b>11.9</b> (10.2-13.7)	<b>13.4</b> (10.9-16.1)	<b>14.6</b> (11.5-17.8)	<b>15.7</b> (11.8-19.9)	<b>16.7</b> (11.9-22.1)	<b>18.0</b> (12.2-24.8)	<b>19.0</b> (12.4-26.9)
<b>60-day</b>	<b>10.2</b> (8.81-11.5)	<b>11.0</b> (9.56-12.6)	<b>12.5</b> (10.8-14.3)	<b>13.7</b> (11.7-15.7)	<b>15.3</b> (12.5-18.3)	<b>16.6</b> (13.1-20.2)	<b>17.8</b> (13.4-22.4)	<b>18.9</b> (13.5-24.8)	<b>20.2</b> (13.7-27.7)	<b>21.2</b> (13.9-29.9)

<sup>1</sup> Precipitation frequency (PF) estimates in this table are based on frequency analysis of partial duration series (PDS). Numbers in parenthesis are PF estimates at lower and upper bounds of the 90% confidence interval. The probability that precipitation frequency estimates (for a given duration and average recurrence interval) will be greater than the upper bound (or less than the lower bound) is 5%. Estimates at upper bounds are not checked against probable maximum precipitation (PMP) estimates and may be higher than currently valid PMP values. Please refer to NOAA Atlas 14 document for more information.

[Back to Top](#)

**PF graphical**

PDS-based depth-duration-frequency (DDF) curves

Latitude: 42.4552°, Longitude: -76.4362°

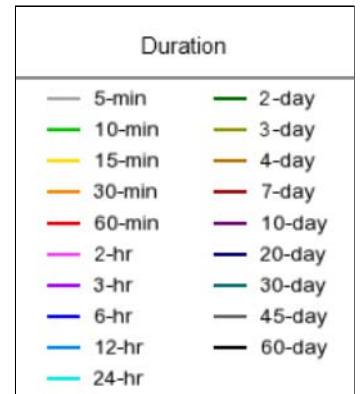
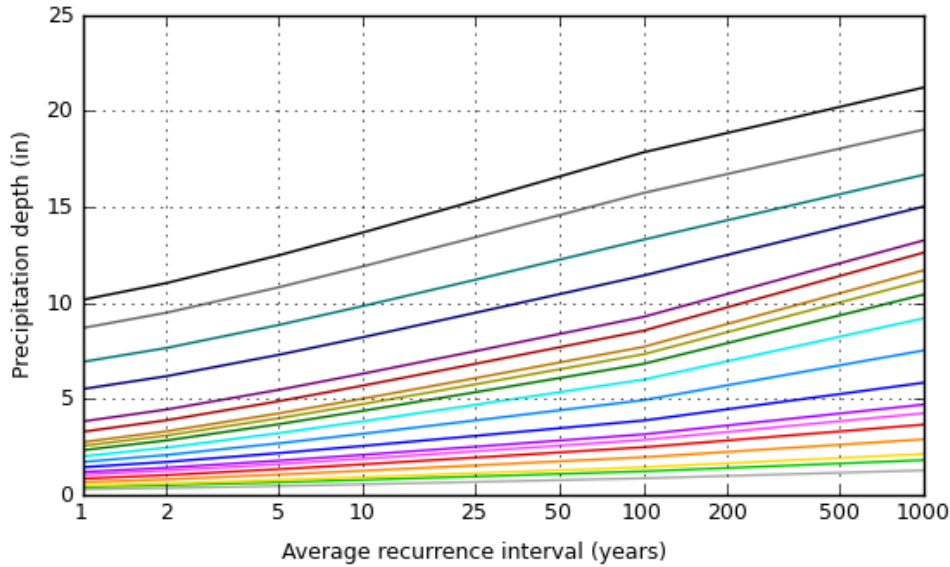
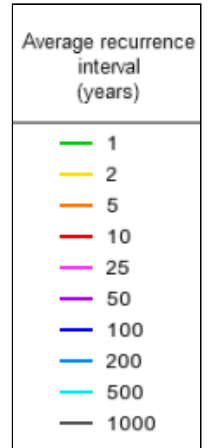
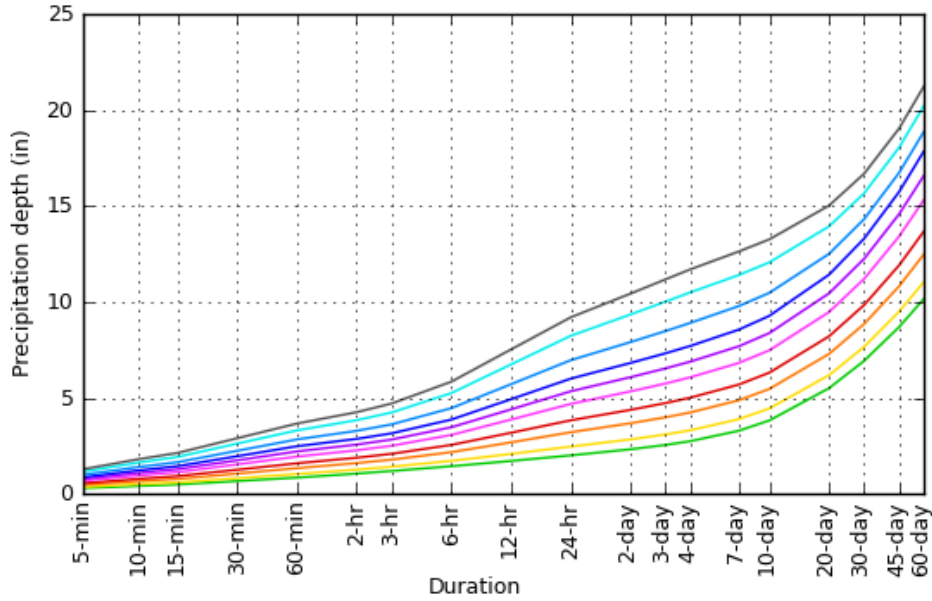

[Back to Top](#)

**Maps & aerials**

**Small scale terrain**

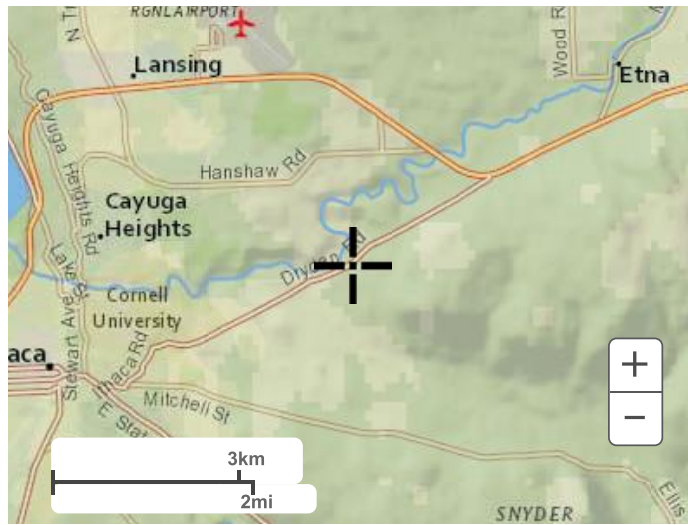

Large scale terrain



Large scale map

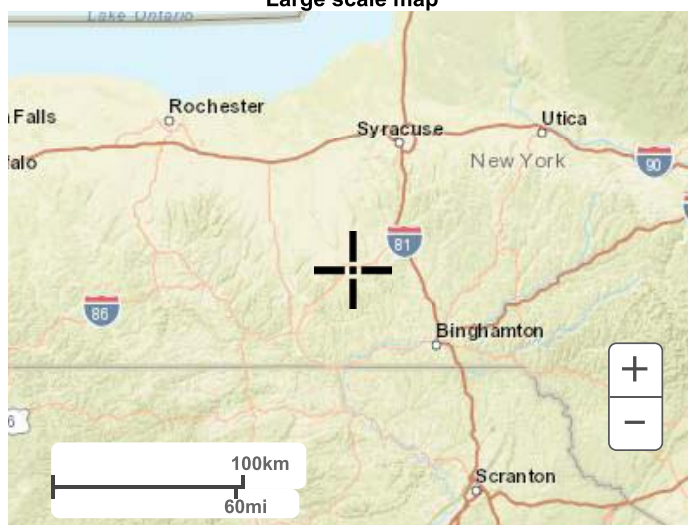

Large scale aerial

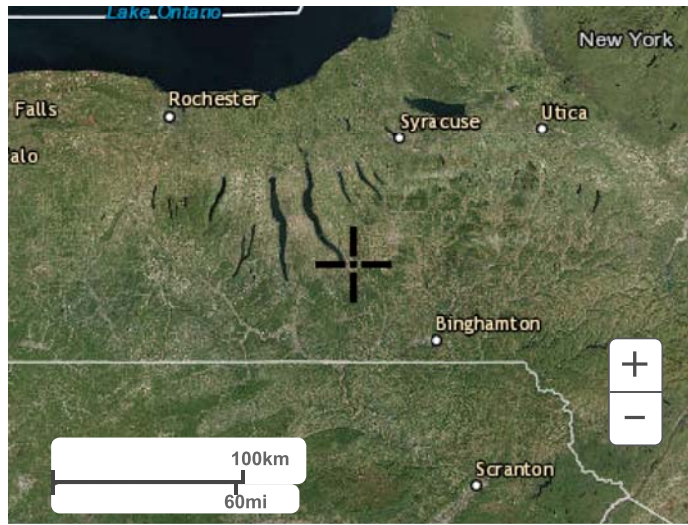

[Back to Top](#)

---

[US Department of Commerce](#)  
[National Oceanic and Atmospheric Administration](#)  
[National Weather Service](#)  
[National Water Center](#)  
1325 East West Highway  
Silver Spring, MD 20910  
Questions?: [HDSC.Questions@noaa.gov](mailto:HDSC.Questions@noaa.gov)

[Disclaimer](#)

**APPENDIX G**  
**Stormwater Calculations**



# Hunt Engineers, Architects, Surveyors

Townhomes at Dryden - (3177-001)

Route 366 Dryden Road, Town of Varna, Tompkins County NY

Design By: JV

Checked By:

Date: 5/9/2018

Revised:

## WATER QUALITY VOLUME CALCULATIONS (WHOLE SITE)

### Required Water Quality Volume Calculations - Proposed Development Only

#### Site Information

Total Project Site:	15.46	acres
Redeveloped Impervious:	0.00	acres
Additional Impervious:	6.87	acres
90% Rainfall Event, Figure 4.1:	1.00	inches

#### Required Water Quality Volume Calculation

<u>WQv for New Impervious</u>		
Project Site Area =	15.46	acres
Effective Impervious Area*** =	6.87	acres
% Impervious =	44%	
WQv from New Imp.* =	0.580	acre-ft      25265 CUFT
Min. Runoff Reduction Volume* =	0.162	acre-ft      7057 CUFT
 <u>WQv for Redeveloped Impervious</u>		
Impervious Area =	0.00	acres
% Impervious =	100%	
WQv from Redev. Imp.** =	0.000	acre-ft      0 CUFT
 Total WQv required (standard SMP)=		
	0.580	acre-ft      25265 CUFT
Total WQv required (other SMP, 25%)=		
	0.000	acre-ft      0 CUFT
<b>Total WQv required =</b>	<b>0.580</b>	<b>acre-ft      25265 CUFT</b>
<b>Total RRv required =</b>	<b>0.162</b>	<b>acre-ft      7057 CUFT</b>

\*NYSDEC regulations require that Green Infrastructure Techniques and Water Quality Treatment be provided for increased impervious areas in accordance with the standard development regulations. Given the soil characteristics of the site, a minimum runoff reduction volume is required.

\*\*NYSDEC regulations require that at least 25% of the water quality volume from redeveloped areas be treated by standard management practices or at least 75% be treated by alternative management practices.

### Minimum Runoff Reduction Volume Factor

	Acres	RRv Factor	
HSG A:	0.00	0.55	
HSG B:	0.00	0.40	
HSG C:	12.26	0.30	
HSG D:	3.20	0.20	
<b>Total Site Area:</b>	<b>15.46</b>	<b>0.28</b>	<b>(Weighted Factor for Project)</b>

FROM NYSDEC STORMWATER MANAGEMENT DESIGN MANUAL:  $WQv=(P)*(Rv)*(A)/12$ ;  $Rv=0.05+0.009*(I)$  (P=90% Rainfall Event, A=Site Area, I=% Impervious Cover)

FROM NYSDEC STORMWATER MANAGEMENT DESIGN MANUAL:  $Equiv. CN = 1000/[10+5*P+10*Q-10*(Q^2+1.25*Q*P)^{0.5}]$ ;  $Q=WQv*12/A$  (P=90% Rainfall Event, A=Site Area)

### Design Water Quality Volume Calculations - By BMP (See separate design sheets for Detention system and Existing infiltration basin)

# Hunt Engineers, Architects, Surveyors

Townhomes at Dryden - (3177-001)

Route 366 Dryden Road, Town of Varna, Tompkins County NY

Design By: JV

Checked By:

Date: 5/9/2018

Revised:

## WATER QUALITY VOLUME CALCULATIONS (WHOLE SITE)

### BMP Drainage Area Information

### Required Water Quality Volume Calculation by Drainage Area

#### SMP - PROPOSED INFILTRATION BASIN-1

Total Drainage Area: 3.29  
 Qualifying Impervious Area: 0.96  
 90 % Rainfall Event, Figure 4.1: 1.05  
 Equivilant CN for TR-55: 89.3

#### SMP - PROPOSED INFILTRATION BASIN-1

Drainage Area = 3.29 acres  
 Impervious Area = 0.96 acres  
 % Impervious = 29%  
 WQv Provided = 0.090 acre-ft 3920 CUFT  
 Runoff Reduction Volume = 0.025 acre-ft 1089 CUFT

#### SMP - PROPOSED INFILTRATION BASIN-2

Total Drainage Area: 9.60  
 Qualifying Impervious Area: 4.96  
 90 % Rainfall Event, Figure 4.1: 1.05  
 Equivilant CN for TR-55: 93.9

#### SMP - PROPOSED INFILTRATION BASIN-2

Drainage Area = 9.60 acres  
 Impervious Area = 4.96 acres  
 % Impervious = 52%  
 WQv Provided = 0.433 acre-ft 18844 CUFT  
 Runoff Reduction Volume = 0.121 acre-ft 5271 CUFT

#### SMP - PROPOSED DETENTION & INFILTRATION

Total Drainage Area: 2.60  
 Qualifying Impervious Area: 0.94  
 90 % Rainfall Event, Figure 4.1: 1.05  
 Equivilant CN for TR-55: 91.0

#### SMP - PROPOSED DETENTION & INFILTRATION

Drainage Area = 2.60 acres  
 Impervious Area = 0.94 acres  
 % Impervious = 36%  
 WQv Provided = 0.085 acre-ft 3720 CUFT  
 Runoff Reduction Volume = 0.024 acre-ft 1045 CUFT

### Provided Runoff Reduction and Water Quality Volume Calculations

	<u>RRv</u>	<u>WQv</u>
SMP - PROPOSED INFILTRATION BASIN-1	3920 CUFT	3920 CUFT
SMP - PROPOSED INFILTRATION BASIN-2	18844 CUFT	18844 CUFT
SMP - PROPOSED DETENTION & INFILTRATION	3720 CUFT	3720 CUFT
Total Provided =	26484 CUFT	26484 CUFT
Total Required =	7057 CUFT	25265 CUFT

FROM NYSDEC STORMWATER MANAGEMENT DESIGN MANUAL:  $WQv=(P)*(Rv)*(A)/12$ ;  $Rv=0.05+0.009*(I)$  (P=90% Rainfall Event, A=Site Area, I=% Impervious Cover)

FROM NYSDEC STORMWATER MANAGEMENT DESIGN MANUAL:  $Equiv. CN = 1000/[10+5*P+10*Q-10*(Q^2+1.25*Q*P)^{0.5}]$ ;  $Q=WQv*12/A$  (P=90% Rainfall Event, A=Site Area)

# Hunt Engineers, Architects, Surveyors

Townhomes at Dryden - (3177-001)

Route 366 Dryden Road, Town of Varna, Tompkins County NY

Design By: JV

Checked By:

Date: 5/9/2018

Revised:

## STORMTECH SC-740 CHAMBER DESIGN

Base Stone Thickness (in) 6

### SC-740 Chamber Info

Length (in) 85.4

Width (in) 51

Height (in) 30

# Rows 9

Chambers per Row 20

Total Length (ft) 145.3

Total Width (ft) 44.3

Total Surface Area (ft<sup>2</sup>) 6431.0

Infiltration Rate (in/hr) 0.10

Infiltration Flow Rate(ft<sup>3</sup>/s) 0.015

12hr inf volume 643.10 13947.05

24hr inf volume 1286.20 14590.15

Bottom of stone under Chamber

Top of stone under Chamber

Top of Chamber

Top of stone above Chamber

Elevation	Depth of water in the system (ft)	Chamber Storage per Chamber (ft <sup>3</sup> )	Chamber Storage (ft <sup>3</sup> )	Stone Storage per chamber (ft <sup>3</sup> )	Stone Storage (ft <sup>3</sup> )	Border Stone Storage (ft <sup>3</sup> )	Cumulative Storage (ft <sup>3</sup> )	Cumulative System storage (Ac-ft)
935.00	0.00	0.00	0.00	0.00	0.00	0.00	0.00	0.000
935.25	0.25	0.00	0.00	3.38	608.40	86.56	694.96	0.016
935.50	0.50	0.00	0.00	6.76	1216.80	173.13	1389.93	0.032
935.75	0.75	6.58	1184.40	14.09	1351.80	259.69	2795.89	0.064
936.00	1.00	12.97	2334.60	21.31	1501.20	346.25	4182.05	0.096
936.25	1.25	19.09	3436.20	28.36	1668.60	432.81	5537.61	0.127
936.50	1.50	24.89	4480.20	35.23	1861.20	519.38	6860.78	0.158
936.75	1.75	30.29	5452.20	41.85	2080.80	605.94	8138.94	0.187
937.00	2.00	35.22	6339.60	48.19	2334.60	692.50	9366.70	0.215
937.25	2.25	39.54	7117.20	54.17	2633.40	779.06	10529.66	0.242
937.50	2.50	43.06	7750.80	59.66	2988.00	865.63	11604.43	0.266
937.75	2.75	45.41	8173.80	64.46	3429.00	952.19	12554.99	0.288
938.00	3.00	45.90	8262.00	68.14	4003.20	1038.75	13303.95	0.305
938.25	3.25	45.90	8262.00	71.52	4611.60	1125.31	13998.91	0.321
938.50	3.50	45.90	8262.00	74.90	5220.00	1211.88	14693.88	0.337
1602.75	3.75	45.90	8262.00	76.03	5423.40	231208.44	244893.84	5.622
939.00	4.00	45.90	8262.00	77.16	5626.80	1385.00	15273.80	0.351
939.50	4.25	45.90	8262.00	78.29	5830.20	1558.13	15650.33	0.359
940.00	4.25	45.90	8262.00	79.42	6033.60	1731.25	16026.85	0.368

# Hunt Engineers, Architects, Surveyors

Townhomes at Dryaden - (3177.001)

Proposed infiltration basin

Design By: JV

Checked By:

Date: 05-2018

Revised:

## Infiltration Basin - WQv and CPv Calculations

### Water Quality Volume Calculations

Type of BMP: Infiltration Basin (I-2)  
 Water Quality Volume to BMP: 11,199 cu-ft  
  
 Pretreatment Volume Required (50%): 5600 cu-ft  
 Pretreatment Method: Treatment Unit  
  
 Bottom of Basin Elevation: 942.00  
 Low Flow Outlet Elevation: 944.50  
 Basin Holding Volume\*\*: 22,910 cu-ft

### Infiltration Basin Volume

Elev.	Area (ac)	Cum. Vol (ac-ft)	Cum. Vol (cf)	Notes
942.0	0.140		0	Infiltration zone
942.5		0.151		
943.0	0.163		6,595	Infiltration zone
943.5		0.175		
944.0	0.187		14,214	Infiltration zone
944.5		0.200		xx" orifice
945.0	0.212		22,910	
945.5		0.226		xx" orifice
946.0	0.239		32,742	
946.5		0.253		
947.0	0.267		43,767	
947.5		0.282		Top of Structure
948.0	0.296		56,040	
948.5		0.312		Em spillway
949.0	0.327		69,615	
949.5		0.343		
950.0	0.359		84,550	Top of Berm

Assumed Infiltration Rate: 0.1 in/hr  
 0.00 ft<sup>3</sup>/S  
 Temporary Ponding Depth: 2.50 ft  
 Time to drain Temporary Ponding: 300.0 hours

\*\*The Basin Holding Volume is the most conservative estimate of the water quality treatment. Additional water quality treatment is provided when the infiltration rate of the basin is taken into account.

### Channel Protection Volume Calculations

Required Channel Protection Volume: 0.063 ac-ft  
 Basin Holding Volume: 0.282 ac-ft

\*\*The Basin Holding Volume is the most conservative estimate of the channel protection volume provided. As allowed in the SWM manual Section 4.4, the CPv requirement can be met by infiltrating the required channel protection volume.

**APPENDIX H**  
**Hydrologic Calculations**

---

Project Summary

---

Title

Engineer

Company

Date 3/7/2019

---

---

Notes

---

## Table of Contents

	Master Network Summary	2
Ithaca	100-Year	
	Time-Depth Curve	4
	Time-Depth Curve	6
	Time-Depth Curve	8
	Time-Depth Curve	10
Pre-Development DA-1a	Time of Concentration Calculations	12
Pre-Development DA-1a	1-Year	
	Runoff CN-Area	14
Pre-Development DA-1b	1-Year	
	Runoff CN-Area	15
Pre-Development DA-2	1-Year	
	Runoff CN-Area	16
Pre-Development DA-3	1-Year	
	Runoff CN-Area	17
Pre-Development DA-1 Offsite	1-Year	
	Unit Hydrograph Summary	18
	Unit Hydrograph Summary	20
	Unit Hydrograph Summary	22
	Unit Hydrograph Summary	24
Pre-Development DA-1a	1-Year	
	Unit Hydrograph Summary	26
	Unit Hydrograph Summary	28
	Unit Hydrograph Summary	30
	Unit Hydrograph Summary	32
Pre-Development DA-1b	1-Year	
	Unit Hydrograph Summary	34
	Unit Hydrograph Summary	36
	Unit Hydrograph Summary	38
	Unit Hydrograph Summary	40
Pre-Development DA-2	1-Year	

## Table of Contents

	Unit Hydrograph Summary	42
	Unit Hydrograph Summary	44
	Unit Hydrograph Summary	46
	Unit Hydrograph Summary	48
Pre-Development DA-2 Offsite	1-Year	
	Unit Hydrograph Summary	50
	Unit Hydrograph Summary	52
	Unit Hydrograph Summary	54
	Unit Hydrograph Summary	56
Pre-Development DA-3	1-Year	
	Unit Hydrograph Summary	58
	Unit Hydrograph Summary	60
	Unit Hydrograph Summary	62
	Unit Hydrograph Summary	64
Pre-Development DA-3 Offsite	1-Year	
	Unit Hydrograph Summary	66
	Unit Hydrograph Summary	68
	Unit Hydrograph Summary	70
	Unit Hydrograph Summary	72



Subsection: Master Network Summary

**Catchments Summary**

Label	Scenario	Return Event (years)	Hydrograph Volume (ac-ft)	Time to Peak (hours)	Peak Flow (ft <sup>3</sup> /s)
Pre-Development DA-1a	Pre-Development 1-Year	1	0.237	12.100	2.93
Pre-Development DA-1a	Pre-Development 10-Year	10	0.884	12.050	12.56
Pre-Development DA-1a	Pre-Development 25-Year	25	1.244	12.050	17.78
Pre-Development DA-1a	Pre-Development 100-Year	100	1.828	12.050	26.09
Pre-Development DA-2	Pre-Development 1-Year	1	0.168	12.000	2.47
Pre-Development DA-2	Pre-Development 10-Year	10	0.624	12.000	10.27
Pre-Development DA-2	Pre-Development 25-Year	25	0.878	12.000	14.46
Pre-Development DA-2	Pre-Development 100-Year	100	1.291	12.000	21.12
Pre-Development DA-3	Pre-Development 1-Year	1	0.218	12.050	2.79
Pre-Development DA-3	Pre-Development 10-Year	10	0.813	12.050	11.81
Pre-Development DA-3	Pre-Development 25-Year	25	1.143	12.050	16.68
Pre-Development DA-3	Pre-Development 100-Year	100	1.680	12.050	24.44
Pre-Development DA-1b	Pre-Development 1-Year	1	0.111	12.150	1.10
Pre-Development DA-1b	Pre-Development 10-Year	10	0.466	12.100	5.81
Pre-Development DA-1b	Pre-Development 25-Year	25	0.670	12.100	8.49
Pre-Development DA-1b	Pre-Development 100-Year	100	1.006	12.100	12.82
Pre-Development DA-1 Offsite	Pre-Development 1-Year	1	0.335	12.200	3.37
Pre-Development DA-1 Offsite	Pre-Development 10-Year	10	0.968	12.200	9.98
Pre-Development DA-1 Offsite	Pre-Development 25-Year	25	1.293	12.200	13.26
Pre-Development DA-1 Offsite	Pre-Development 100-Year	100	1.804	12.200	18.31
Pre-Development DA-2 Offsite	Pre-Development 1-Year	1	4.358	12.300	33.86
Pre-Development DA-2 Offsite	Pre-Development 10-Year	10	15.704	12.250	142.00
Pre-Development DA-2 Offsite	Pre-Development 25-Year	25	21.951	12.250	200.59
Pre-Development DA-2 Offsite	Pre-Development 100-Year	100	32.047	12.250	293.80

Subsection: Master Network Summary

**Catchments Summary**

Label	Scenario	Return Event (years)	Hydrograph Volume (ac-ft)	Time to Peak (hours)	Peak Flow (ft <sup>3</sup> /s)
Pre-Development DA-3 Offsite	Pre-Development 1-Year	1	0.248	12.150	2.54
Pre-Development DA-3 Offsite	Pre-Development 10-Year	10	0.894	12.150	10.30
Pre-Development DA-3 Offsite	Pre-Development 25-Year	25	1.250	12.150	14.46
Pre-Development DA-3 Offsite	Pre-Development 100-Year	100	1.824	12.100	21.18

**Node Summary**

Label	Scenario	Return Event (years)	Hydrograph Volume (ac-ft)	Time to Peak (hours)	Peak Flow (ft <sup>3</sup> /s)
Pre-Development Outfall-1	Pre-Development 1-Year	1	0.683	12.100	6.98
Pre-Development Outfall-1	Pre-Development 10-Year	10	2.318	12.100	26.86
Pre-Development Outfall-1	Pre-Development 25-Year	25	3.207	12.100	37.45
Pre-Development Outfall-1	Pre-Development 100-Year	100	4.638	12.100	54.19
Pre-Development Outfall-2	Pre-Development 1-Year	1	4.525	12.300	34.49
Pre-Development Outfall-2	Pre-Development 10-Year	10	16.328	12.250	144.52
Pre-Development Outfall-2	Pre-Development 25-Year	25	22.829	12.250	204.03
Pre-Development Outfall-2	Pre-Development 100-Year	100	33.338	12.250	298.68
Pre-Development Outfall-3	Pre-Development 1-Year	1	0.466	12.100	5.16
Pre-Development Outfall-3	Pre-Development 10-Year	10	1.707	12.100	21.23
Pre-Development Outfall-3	Pre-Development 25-Year	25	2.393	12.050	29.95
Pre-Development Outfall-3	Pre-Development 100-Year	100	3.504	12.050	44.06

Subsection: Time-Depth Curve  
 Label: Ithaca

Return Event: 100 years  
 Storm Event: 100-Year

---

Time-Depth Curve: 100-Year

---

Label	100-Year
Start Time	0.000 hours
Increment	0.100 hours
End Time	24.000 hours
Return Event	100 years

---

**CUMULATIVE RAINFALL (in)**  
**Output Time Increment = 0.100 hours**  
**Time on left represents time for first value in each row.**

Time (hours)	Depth (in)	Depth (in)	Depth (in)	Depth (in)	Depth (in)
0.000	0.0	0.0	0.0	0.0	0.0
0.500	0.0	0.0	0.0	0.1	0.1
1.000	0.1	0.1	0.1	0.1	0.1
1.500	0.1	0.1	0.1	0.1	0.1
2.000	0.1	0.1	0.1	0.2	0.2
2.500	0.2	0.2	0.2	0.2	0.2
3.000	0.2	0.2	0.2	0.2	0.2
3.500	0.2	0.3	0.3	0.3	0.3
4.000	0.3	0.3	0.3	0.3	0.3
4.500	0.3	0.3	0.4	0.4	0.4
5.000	0.4	0.4	0.4	0.4	0.4
5.500	0.4	0.4	0.4	0.5	0.5
6.000	0.5	0.5	0.5	0.5	0.5
6.500	0.5	0.5	0.6	0.6	0.6
7.000	0.6	0.6	0.6	0.6	0.6
7.500	0.7	0.7	0.7	0.7	0.7
8.000	0.7	0.7	0.7	0.8	0.8
8.500	0.8	0.8	0.8	0.8	0.9
9.000	0.9	0.9	0.9	0.9	1.0
9.500	1.0	1.0	1.0	1.0	1.1
10.000	1.1	1.1	1.1	1.2	1.2
10.500	1.2	1.3	1.3	1.3	1.4
11.000	1.4	1.5	1.5	1.6	1.6
11.500	1.7	1.8	2.1	2.6	3.4
12.000	4.0	4.1	4.2	4.3	4.4
12.500	4.4	4.5	4.5	4.6	4.6
13.000	4.6	4.7	4.7	4.7	4.8
13.500	4.8	4.8	4.9	4.9	4.9
14.000	4.9	5.0	5.0	5.0	5.0
14.500	5.0	5.1	5.1	5.1	5.1
15.000	5.1	5.1	5.2	5.2	5.2
15.500	5.2	5.2	5.2	5.3	5.3
16.000	5.3	5.3	5.3	5.3	5.3
16.500	5.4	5.4	5.4	5.4	5.4
17.000	5.4	5.4	5.4	5.5	5.5
17.500	5.5	5.5	5.5	5.5	5.5

Subsection: Time-Depth Curve  
 Label: Ithaca

Return Event: 100 years  
 Storm Event: 100-Year

**CUMULATIVE RAINFALL (in)**  
**Output Time Increment = 0.100 hours**  
**Time on left represents time for first value in each row.**

Time (hours)	Depth (in)	Depth (in)	Depth (in)	Depth (in)	Depth (in)
18.000	5.5	5.5	5.6	5.6	5.6
18.500	5.6	5.6	5.6	5.6	5.6
19.000	5.6	5.6	5.7	5.7	5.7
19.500	5.7	5.7	5.7	5.7	5.7
20.000	5.7	5.7	5.7	5.7	5.8
20.500	5.8	5.8	5.8	5.8	5.8
21.000	5.8	5.8	5.8	5.8	5.8
21.500	5.8	5.8	5.9	5.9	5.9
22.000	5.9	5.9	5.9	5.9	5.9
22.500	5.9	5.9	5.9	5.9	5.9
23.000	5.9	5.9	6.0	6.0	6.0
23.500	6.0	6.0	6.0	6.0	6.0
24.000	6.0	(N/A)	(N/A)	(N/A)	(N/A)

Subsection: Time-Depth Curve  
 Label: Ithaca

Return Event: 10 years  
 Storm Event: 10-Year

Time-Depth Curve: 10-Year

Label	10-Year
Start Time	0.000 hours
Increment	0.100 hours
End Time	24.000 hours
Return Event	10 years

**CUMULATIVE RAINFALL (in)**

**Output Time Increment = 0.100 hours**

**Time on left represents time for first value in each row.**

Time (hours)	Depth (in)	Depth (in)	Depth (in)	Depth (in)	Depth (in)
0.000	0.0	0.0	0.0	0.0	0.0
0.500	0.0	0.0	0.0	0.0	0.0
1.000	0.0	0.0	0.0	0.1	0.1
1.500	0.1	0.1	0.1	0.1	0.1
2.000	0.1	0.1	0.1	0.1	0.1
2.500	0.1	0.1	0.1	0.1	0.1
3.000	0.1	0.1	0.1	0.1	0.2
3.500	0.2	0.2	0.2	0.2	0.2
4.000	0.2	0.2	0.2	0.2	0.2
4.500	0.2	0.2	0.2	0.2	0.2
5.000	0.2	0.2	0.3	0.3	0.3
5.500	0.3	0.3	0.3	0.3	0.3
6.000	0.3	0.3	0.3	0.3	0.3
6.500	0.3	0.4	0.4	0.4	0.4
7.000	0.4	0.4	0.4	0.4	0.4
7.500	0.4	0.4	0.4	0.4	0.5
8.000	0.5	0.5	0.5	0.5	0.5
8.500	0.5	0.5	0.5	0.5	0.6
9.000	0.6	0.6	0.6	0.6	0.6
9.500	0.6	0.6	0.7	0.7	0.7
10.000	0.7	0.7	0.7	0.7	0.8
10.500	0.8	0.8	0.8	0.9	0.9
11.000	0.9	0.9	1.0	1.0	1.0
11.500	1.1	1.2	1.4	1.7	2.2
12.000	2.5	2.6	2.7	2.7	2.8
12.500	2.8	2.9	2.9	2.9	2.9
13.000	3.0	3.0	3.0	3.0	3.0
13.500	3.1	3.1	3.1	3.1	3.1
14.000	3.1	3.2	3.2	3.2	3.2
14.500	3.2	3.2	3.2	3.3	3.3
15.000	3.3	3.3	3.3	3.3	3.3
15.500	3.3	3.3	3.4	3.4	3.4
16.000	3.4	3.4	3.4	3.4	3.4
16.500	3.4	3.4	3.4	3.4	3.5
17.000	3.5	3.5	3.5	3.5	3.5
17.500	3.5	3.5	3.5	3.5	3.5

Subsection: Time-Depth Curve  
 Label: Ithaca

Return Event: 10 years  
 Storm Event: 10-Year

**CUMULATIVE RAINFALL (in)**  
**Output Time Increment = 0.100 hours**  
**Time on left represents time for first value in each row.**

Time (hours)	Depth (in)	Depth (in)	Depth (in)	Depth (in)	Depth (in)
18.000	3.5	3.5	3.6	3.6	3.6
18.500	3.6	3.6	3.6	3.6	3.6
19.000	3.6	3.6	3.6	3.6	3.6
19.500	3.6	3.6	3.6	3.6	3.7
20.000	3.7	3.7	3.7	3.7	3.7
20.500	3.7	3.7	3.7	3.7	3.7
21.000	3.7	3.7	3.7	3.7	3.7
21.500	3.7	3.7	3.7	3.7	3.7
22.000	3.8	3.8	3.8	3.8	3.8
22.500	3.8	3.8	3.8	3.8	3.8
23.000	3.8	3.8	3.8	3.8	3.8
23.500	3.8	3.8	3.8	3.8	3.8
24.000	3.8	(N/A)	(N/A)	(N/A)	(N/A)

Subsection: Time-Depth Curve  
 Label: Ithaca

Return Event: 1 years  
 Storm Event: 1-Year

---

Time-Depth Curve: 1-Year

---

Label	1-Year
Start Time	0.000 hours
Increment	0.100 hours
End Time	24.000 hours
Return Event	1 years

---

**CUMULATIVE RAINFALL (in)**  
**Output Time Increment = 0.100 hours**  
**Time on left represents time for first value in each row.**

Time (hours)	Depth (in)	Depth (in)	Depth (in)	Depth (in)	Depth (in)
0.000	0.0	0.0	0.0	0.0	0.0
0.500	0.0	0.0	0.0	0.0	0.0
1.000	0.0	0.0	0.0	0.0	0.0
1.500	0.0	0.0	0.0	0.0	0.0
2.000	0.0	0.0	0.0	0.1	0.1
2.500	0.1	0.1	0.1	0.1	0.1
3.000	0.1	0.1	0.1	0.1	0.1
3.500	0.1	0.1	0.1	0.1	0.1
4.000	0.1	0.1	0.1	0.1	0.1
4.500	0.1	0.1	0.1	0.1	0.1
5.000	0.1	0.1	0.1	0.1	0.1
5.500	0.1	0.1	0.2	0.2	0.2
6.000	0.2	0.2	0.2	0.2	0.2
6.500	0.2	0.2	0.2	0.2	0.2
7.000	0.2	0.2	0.2	0.2	0.2
7.500	0.2	0.2	0.2	0.2	0.2
8.000	0.2	0.2	0.3	0.3	0.3
8.500	0.3	0.3	0.3	0.3	0.3
9.000	0.3	0.3	0.3	0.3	0.3
9.500	0.3	0.3	0.3	0.3	0.4
10.000	0.4	0.4	0.4	0.4	0.4
10.500	0.4	0.4	0.4	0.4	0.5
11.000	0.5	0.5	0.5	0.5	0.5
11.500	0.6	0.6	0.7	0.9	1.1
12.000	1.3	1.4	1.4	1.4	1.5
12.500	1.5	1.5	1.5	1.5	1.5
13.000	1.6	1.6	1.6	1.6	1.6
13.500	1.6	1.6	1.6	1.6	1.6
14.000	1.6	1.7	1.7	1.7	1.7
14.500	1.7	1.7	1.7	1.7	1.7
15.000	1.7	1.7	1.7	1.7	1.7
15.500	1.7	1.7	1.8	1.8	1.8
16.000	1.8	1.8	1.8	1.8	1.8
16.500	1.8	1.8	1.8	1.8	1.8
17.000	1.8	1.8	1.8	1.8	1.8
17.500	1.8	1.8	1.8	1.8	1.8

Subsection: Time-Depth Curve  
 Label: Ithaca

Return Event: 1 years  
 Storm Event: 1-Year

**CUMULATIVE RAINFALL (in)**  
**Output Time Increment = 0.100 hours**  
**Time on left represents time for first value in each row.**

Time (hours)	Depth (in)	Depth (in)	Depth (in)	Depth (in)	Depth (in)
18.000	1.9	1.9	1.9	1.9	1.9
18.500	1.9	1.9	1.9	1.9	1.9
19.000	1.9	1.9	1.9	1.9	1.9
19.500	1.9	1.9	1.9	1.9	1.9
20.000	1.9	1.9	1.9	1.9	1.9
20.500	1.9	1.9	1.9	1.9	1.9
21.000	1.9	1.9	1.9	1.9	1.9
21.500	2.0	2.0	2.0	2.0	2.0
22.000	2.0	2.0	2.0	2.0	2.0
22.500	2.0	2.0	2.0	2.0	2.0
23.000	2.0	2.0	2.0	2.0	2.0
23.500	2.0	2.0	2.0	2.0	2.0
24.000	2.0	(N/A)	(N/A)	(N/A)	(N/A)



Subsection: Time-Depth Curve  
 Label: Ithaca

Return Event: 25 years  
 Storm Event: 25-Year

---

Time-Depth Curve: 25-Year

---

Label	25-Year
Start Time	0.000 hours
Increment	0.100 hours
End Time	24.000 hours
Return Event	25 years

---

**CUMULATIVE RAINFALL (in)**  
**Output Time Increment = 0.100 hours**  
**Time on left represents time for first value in each row.**

Time (hours)	Depth (in)	Depth (in)	Depth (in)	Depth (in)	Depth (in)
0.000	0.0	0.0	0.0	0.0	0.0
0.500	0.0	0.0	0.0	0.0	0.0
1.000	0.0	0.1	0.1	0.1	0.1
1.500	0.1	0.1	0.1	0.1	0.1
2.000	0.1	0.1	0.1	0.1	0.1
2.500	0.1	0.1	0.1	0.2	0.2
3.000	0.2	0.2	0.2	0.2	0.2
3.500	0.2	0.2	0.2	0.2	0.2
4.000	0.2	0.2	0.2	0.2	0.3
4.500	0.3	0.3	0.3	0.3	0.3
5.000	0.3	0.3	0.3	0.3	0.3
5.500	0.3	0.3	0.4	0.4	0.4
6.000	0.4	0.4	0.4	0.4	0.4
6.500	0.4	0.4	0.4	0.4	0.5
7.000	0.5	0.5	0.5	0.5	0.5
7.500	0.5	0.5	0.5	0.5	0.6
8.000	0.6	0.6	0.6	0.6	0.6
8.500	0.6	0.6	0.6	0.7	0.7
9.000	0.7	0.7	0.7	0.7	0.8
9.500	0.8	0.8	0.8	0.8	0.8
10.000	0.9	0.9	0.9	0.9	0.9
10.500	1.0	1.0	1.0	1.0	1.1
11.000	1.1	1.1	1.2	1.2	1.3
11.500	1.3	1.4	1.7	2.0	2.7
12.000	3.1	3.2	3.3	3.4	3.4
12.500	3.5	3.5	3.5	3.6	3.6
13.000	3.6	3.7	3.7	3.7	3.7
13.500	3.8	3.8	3.8	3.8	3.8
14.000	3.9	3.9	3.9	3.9	3.9
14.500	3.9	4.0	4.0	4.0	4.0
15.000	4.0	4.0	4.0	4.1	4.1
15.500	4.1	4.1	4.1	4.1	4.1
16.000	4.1	4.1	4.2	4.2	4.2
16.500	4.2	4.2	4.2	4.2	4.2
17.000	4.2	4.2	4.3	4.3	4.3
17.500	4.3	4.3	4.3	4.3	4.3

Subsection: Time-Depth Curve  
 Label: Ithaca

Return Event: 25 years  
 Storm Event: 25-Year

**CUMULATIVE RAINFALL (in)**  
**Output Time Increment = 0.100 hours**  
**Time on left represents time for first value in each row.**

Time (hours)	Depth (in)	Depth (in)	Depth (in)	Depth (in)	Depth (in)
18.000	4.3	4.3	4.3	4.4	4.4
18.500	4.4	4.4	4.4	4.4	4.4
19.000	4.4	4.4	4.4	4.4	4.4
19.500	4.4	4.4	4.5	4.5	4.5
20.000	4.5	4.5	4.5	4.5	4.5
20.500	4.5	4.5	4.5	4.5	4.5
21.000	4.5	4.5	4.5	4.6	4.6
21.500	4.6	4.6	4.6	4.6	4.6
22.000	4.6	4.6	4.6	4.6	4.6
22.500	4.6	4.6	4.6	4.6	4.6
23.000	4.6	4.7	4.7	4.7	4.7
23.500	4.7	4.7	4.7	4.7	4.7
24.000	4.7	(N/A)	(N/A)	(N/A)	(N/A)

Subsection: Time of Concentration Calculations  
Label: Pre-Development DA-1a

Return Event: 1 years  
Storm Event: 1-Year

Time of Concentration Results

---

Segment #1: TR-55 Sheet Flow

---

Hydraulic Length	100.00 ft
Manning's n	0.350
Slope	0.070 ft/ft
2 Year 24 Hour Depth	2.5 in
Average Velocity	0.13 ft/s
Segment Time of Concentration	0.222 hours

---

---

Segment #2: TR-55 Shallow Concentrated Flow

---

Hydraulic Length	630.00 ft
Is Paved?	False
Slope	0.070 ft/ft
Average Velocity	4.27 ft/s
Segment Time of Concentration	0.041 hours

---

---

Time of Concentration (Composite)

---

Time of Concentration (Composite)	0.263 hours
-----------------------------------	-------------

---

Subsection: Time of Concentration Calculations  
Label: Pre-Development DA-1a

Return Event: 1 years  
Storm Event: 1-Year

**==== SCS Channel Flow**

$R = Qa / Wp$   
 $V = (1.49 * (R^{2/3}) * (Sf^{0.5})) / n$   
 $Tc = (Lf / V) / 3600$   
R= Hydraulic radius  
Aq= Flow area, square feet  
Wp= Wetted perimeter, feet  
V= Velocity, ft/sec  
Where: Sf= Slope, ft/ft  
n= Manning's n  
Tc= Time of concentration, hours  
Lf= Flow length, feet

**==== SCS TR-55 Shallow Concentration Flow**

Unpaved surface:  
 $V = 16.1345 * (Sf^{0.5})$   
Tc = Paved Surface:  
 $V = 20.3282 * (Sf^{0.5})$   
 $(Lf / V) / 3600$   
V= Velocity, ft/sec  
Where: Sf= Slope, ft/ft  
Tc= Time of concentration, hours  
Lf= Flow length, feet

Subsection: Runoff CN-Area  
 Label: Pre-Development DA-1a

Return Event: 1 years  
 Storm Event: 1-Year

**Runoff Curve Number Data**

Soil/Surface Description	CN	Area (acres)	C (%)	UC (%)	Adjusted CN
Woods - good - Soil D	77.000	2.840	0.0	0.0	77.000
Woods - grass combination - good - Soil C	72.000	2.840	0.0	0.0	72.000
Impervious Areas - Paved parking lots, roofs, driveways, Streets and roads - Soil D	98.000	0.630	0.0	0.0	98.000
COMPOSITE AREA & WEIGHTED CN --->	(N/A)	6.310	(N/A)	(N/A)	76.846

Subsection: Runoff CN-Area  
Label: Pre-Development DA-1b

Return Event: 1 years  
Storm Event: 1-Year

**Runoff Curve Number Data**

Soil/Surface Description	CN	Area (acres)	C (%)	UC (%)	Adjusted CN
Woods - good - Soil D	77.000	1.900	0.0	0.0	77.000
Woods - grass combination - good - Soil C	72.000	1.900	0.0	0.0	72.000
COMPOSITE AREA & WEIGHTED CN --->	(N/A)	3.800	(N/A)	(N/A)	74.500

Subsection: Runoff CN-Area  
 Label: Pre-Development DA-2

Return Event: 1 years  
 Storm Event: 1-Year

**Runoff Curve Number Data**

Soil/Surface Description	CN	Area (acres)	C (%)	UC (%)	Adjusted CN
Woods - good - Soil D	77.000	2.000	0.0	0.0	77.000
Woods - grass combination - good - Soil C	72.000	2.000	0.0	0.0	72.000
Impervious Areas - Paved parking lots, roofs, driveways, Streets and roads - Soil D	98.000	0.450	0.0	0.0	98.000
COMPOSITE AREA & WEIGHTED CN --->	(N/A)	4.450	(N/A)	(N/A)	76.876

Subsection: Runoff CN-Area  
 Label: Pre-Development DA-3

Return Event: 1 years  
 Storm Event: 1-Year

**Runoff Curve Number Data**

Soil/Surface Description	CN	Area (acres)	C (%)	UC (%)	Adjusted CN
Woods - good - Soil D	77.000	2.610	0.0	0.0	77.000
Woods - grass combination - good - Soil C	72.000	2.610	0.0	0.0	72.000
Impervious Areas - Paved parking lots, roofs, driveways, Streets and roads - Soil D	98.000	0.580	0.0	0.0	98.000
COMPOSITE AREA & WEIGHTED CN --->	(N/A)	5.800	(N/A)	(N/A)	76.850



Subsection: Unit Hydrograph Summary  
 Label: Pre-Development DA-1 Offsite

Return Event: 1 years  
 Storm Event: 1-Year

Storm Event	1-Year
Return Event	1 years
Duration	24.000 hours
Depth	2.0 in
Time of Concentration (Composite)	0.500 hours
Area (User Defined)	5.050 acres

Computational Time Increment	0.067 hours
Time to Peak (Computed)	12.200 hours
Flow (Peak, Computed)	3.37 ft <sup>3</sup> /s
Output Increment	0.050 hours
Time to Flow (Peak Interpolated Output)	12.200 hours
Flow (Peak Interpolated Output)	3.37 ft <sup>3</sup> /s

Drainage Area	
SCS CN (Composite)	85.000
Area (User Defined)	5.050 acres
Maximum Retention (Pervious)	1.8 in
Maximum Retention (Pervious, 20 percent)	0.4 in

Cumulative Runoff	
Cumulative Runoff Depth (Pervious)	0.8 in
Runoff Volume (Pervious)	0.338 ac-ft

Hydrograph Volume (Area under Hydrograph curve)	
Volume	0.335 ac-ft

SCS Unit Hydrograph Parameters	
Time of Concentration (Composite)	0.500 hours
Computational Time Increment	0.067 hours
Unit Hydrograph Shape Factor	483.432
K Factor	0.749
Receding/Rising, Tr/Tp	1.670
Unit peak, qp	11.44 ft <sup>3</sup> /s
Unit peak time, Tp	0.333 hours

Subsection: Unit Hydrograph Summary  
Label: Pre-Development DA-1 Offsite

Return Event: 1 years  
Storm Event: 1-Year

---

SCS Unit Hydrograph Parameters

---

Unit receding limb, Tr	1.333 hours
Total unit time, Tb	1.667 hours

---

Subsection: Unit Hydrograph Summary  
 Label: Pre-Development DA-1 Offsite

Return Event: 10 years  
 Storm Event: 10-Year

Storm Event	10-Year
Return Event	10 years
Duration	24.000 hours
Depth	3.8 in
Time of Concentration (Composite)	0.500 hours
Area (User Defined)	5.050 acres

Computational Time Increment	0.067 hours
Time to Peak (Computed)	12.200 hours
Flow (Peak, Computed)	9.98 ft <sup>3</sup> /s
Output Increment	0.050 hours
Time to Flow (Peak Interpolated Output)	12.200 hours
Flow (Peak Interpolated Output)	9.98 ft <sup>3</sup> /s

Drainage Area	
SCS CN (Composite)	85.000
Area (User Defined)	5.050 acres
Maximum Retention (Pervious)	1.8 in
Maximum Retention (Pervious, 20 percent)	0.4 in

Cumulative Runoff	
Cumulative Runoff Depth (Pervious)	2.3 in
Runoff Volume (Pervious)	0.974 ac-ft

Hydrograph Volume (Area under Hydrograph curve)	
Volume	0.968 ac-ft

SCS Unit Hydrograph Parameters	
Time of Concentration (Composite)	0.500 hours
Computational Time Increment	0.067 hours
Unit Hydrograph Shape Factor	483.432
K Factor	0.749
Receding/Rising, Tr/Tp	1.670
Unit peak, qp	11.44 ft <sup>3</sup> /s
Unit peak time, Tp	0.333 hours

Subsection: Unit Hydrograph Summary  
Label: Pre-Development DA-1 Offsite

Return Event: 10 years  
Storm Event: 10-Year

---

SCS Unit Hydrograph Parameters	
Unit receding limb, Tr	1.333 hours
Total unit time, Tb	1.667 hours

---

Subsection: Unit Hydrograph Summary  
 Label: Pre-Development DA-1 Offsite

Return Event: 25 years  
 Storm Event: 25-Year

Storm Event	25-Year
Return Event	25 years
Duration	24.000 hours
Depth	4.7 in
Time of Concentration (Composite)	0.500 hours
Area (User Defined)	5.050 acres

Computational Time Increment	0.067 hours
Time to Peak (Computed)	12.200 hours
Flow (Peak, Computed)	13.26 ft <sup>3</sup> /s
Output Increment	0.050 hours
Time to Flow (Peak Interpolated Output)	12.200 hours
Flow (Peak Interpolated Output)	13.26 ft <sup>3</sup> /s

Drainage Area	
SCS CN (Composite)	85.000
Area (User Defined)	5.050 acres
Maximum Retention (Pervious)	1.8 in
Maximum Retention (Pervious, 20 percent)	0.4 in

Cumulative Runoff	
Cumulative Runoff Depth (Pervious)	3.1 in
Runoff Volume (Pervious)	1.301 ac-ft

Hydrograph Volume (Area under Hydrograph curve)	
Volume	1.293 ac-ft

SCS Unit Hydrograph Parameters	
Time of Concentration (Composite)	0.500 hours
Computational Time Increment	0.067 hours
Unit Hydrograph Shape Factor	483.432
K Factor	0.749
Receding/Rising, Tr/Tp	1.670
Unit peak, qp	11.44 ft <sup>3</sup> /s
Unit peak time, Tp	0.333 hours

Subsection: Unit Hydrograph Summary  
Label: Pre-Development DA-1 Offsite

Return Event: 25 years  
Storm Event: 25-Year

---

SCS Unit Hydrograph Parameters

---

Unit receding limb, Tr	1.333 hours
Total unit time, Tb	1.667 hours

---

Subsection: Unit Hydrograph Summary  
 Label: Pre-Development DA-1 Offsite

Return Event: 100 years  
 Storm Event: 100-Year

Storm Event	100-Year
Return Event	100 years
Duration	24.000 hours
Depth	6.0 in
Time of Concentration (Composite)	0.500 hours
Area (User Defined)	5.050 acres

Computational Time Increment	0.067 hours
Time to Peak (Computed)	12.200 hours
Flow (Peak, Computed)	18.31 ft <sup>3</sup> /s
Output Increment	0.050 hours
Time to Flow (Peak Interpolated Output)	12.200 hours
Flow (Peak Interpolated Output)	18.31 ft <sup>3</sup> /s

Drainage Area	
SCS CN (Composite)	85.000
Area (User Defined)	5.050 acres
Maximum Retention (Pervious)	1.8 in
Maximum Retention (Pervious, 20 percent)	0.4 in

Cumulative Runoff	
Cumulative Runoff Depth (Pervious)	4.3 in
Runoff Volume (Pervious)	1.815 ac-ft

Hydrograph Volume (Area under Hydrograph curve)	
Volume	1.804 ac-ft

SCS Unit Hydrograph Parameters	
Time of Concentration (Composite)	0.500 hours
Computational Time Increment	0.067 hours
Unit Hydrograph Shape Factor	483.432
K Factor	0.749
Receding/Rising, Tr/Tp	1.670
Unit peak, qp	11.44 ft <sup>3</sup> /s
Unit peak time, Tp	0.333 hours

Subsection: Unit Hydrograph Summary  
Label: Pre-Development DA-1 Offsite

Return Event: 100 years  
Storm Event: 100-Year

---

SCS Unit Hydrograph Parameters

---

Unit receding limb, Tr	1.333 hours
Total unit time, Tb	1.667 hours

---



Subsection: Unit Hydrograph Summary  
 Label: Pre-Development DA-1a

Return Event: 1 years  
 Storm Event: 1-Year

Storm Event	1-Year
Return Event	1 years
Duration	24.000 hours
Depth	2.0 in
Time of Concentration (Composite)	0.263 hours
Area (User Defined)	6.310 acres

Computational Time Increment	0.035 hours
Time to Peak (Computed)	12.089 hours
Flow (Peak, Computed)	2.99 ft <sup>3</sup> /s
Output Increment	0.050 hours
Time to Flow (Peak Interpolated Output)	12.100 hours
Flow (Peak Interpolated Output)	2.93 ft <sup>3</sup> /s

Drainage Area	
SCS CN (Composite)	77.000
Area (User Defined)	6.310 acres
Maximum Retention (Pervious)	3.0 in
Maximum Retention (Pervious, 20 percent)	0.6 in

Cumulative Runoff	
Cumulative Runoff Depth (Pervious)	0.5 in
Runoff Volume (Pervious)	0.238 ac-ft

Hydrograph Volume (Area under Hydrograph curve)	
Volume	0.237 ac-ft

SCS Unit Hydrograph Parameters	
Time of Concentration (Composite)	0.263 hours
Computational Time Increment	0.035 hours
Unit Hydrograph Shape Factor	483.432
K Factor	0.749
Receding/Rising, Tr/Tp	1.670
Unit peak, qp	27.21 ft <sup>3</sup> /s
Unit peak time, Tp	0.175 hours

Subsection: Unit Hydrograph Summary  
Label: Pre-Development DA-1a

Return Event: 1 years  
Storm Event: 1-Year

---

SCS Unit Hydrograph Parameters	
Unit receding limb, Tr	0.701 hours
Total unit time, Tb	0.876 hours

---

Subsection: Unit Hydrograph Summary  
 Label: Pre-Development DA-1a

Return Event: 10 years  
 Storm Event: 10-Year

Storm Event	10-Year
Return Event	10 years
Duration	24.000 hours
Depth	3.8 in
Time of Concentration (Composite)	0.263 hours
Area (User Defined)	6.310 acres

Computational Time Increment	0.035 hours
Time to Peak (Computed)	12.054 hours
Flow (Peak, Computed)	12.61 ft <sup>3</sup> /s
Output Increment	0.050 hours
Time to Flow (Peak Interpolated Output)	12.050 hours
Flow (Peak Interpolated Output)	12.56 ft <sup>3</sup> /s

Drainage Area	
SCS CN (Composite)	77.000
Area (User Defined)	6.310 acres
Maximum Retention (Pervious)	3.0 in
Maximum Retention (Pervious, 20 percent)	0.6 in

Cumulative Runoff	
Cumulative Runoff Depth (Pervious)	1.7 in
Runoff Volume (Pervious)	0.888 ac-ft

Hydrograph Volume (Area under Hydrograph curve)	
Volume	0.884 ac-ft

SCS Unit Hydrograph Parameters	
Time of Concentration (Composite)	0.263 hours
Computational Time Increment	0.035 hours
Unit Hydrograph Shape Factor	483.432
K Factor	0.749
Receding/Rising, Tr/Tp	1.670
Unit peak, qp	27.21 ft <sup>3</sup> /s
Unit peak time, Tp	0.175 hours

Subsection: Unit Hydrograph Summary  
Label: Pre-Development DA-1a

Return Event: 10 years  
Storm Event: 10-Year

---

SCS Unit Hydrograph Parameters	
Unit receding limb, Tr	0.701 hours
Total unit time, Tb	0.876 hours

---

Subsection: Unit Hydrograph Summary  
 Label: Pre-Development DA-1a

Return Event: 25 years  
 Storm Event: 25-Year

Storm Event	25-Year
Return Event	25 years
Duration	24.000 hours
Depth	4.7 in
Time of Concentration (Composite)	0.263 hours
Area (User Defined)	6.310 acres

Computational Time Increment	0.035 hours
Time to Peak (Computed)	12.054 hours
Flow (Peak, Computed)	17.83 ft <sup>3</sup> /s
Output Increment	0.050 hours
Time to Flow (Peak Interpolated Output)	12.050 hours
Flow (Peak Interpolated Output)	17.78 ft <sup>3</sup> /s

Drainage Area	
SCS CN (Composite)	77.000
Area (User Defined)	6.310 acres
Maximum Retention (Pervious)	3.0 in
Maximum Retention (Pervious, 20 percent)	0.6 in

Cumulative Runoff	
Cumulative Runoff Depth (Pervious)	2.4 in
Runoff Volume (Pervious)	1.248 ac-ft

Hydrograph Volume (Area under Hydrograph curve)	
Volume	1.244 ac-ft

SCS Unit Hydrograph Parameters	
Time of Concentration (Composite)	0.263 hours
Computational Time Increment	0.035 hours
Unit Hydrograph Shape Factor	483.432
K Factor	0.749
Receding/Rising, Tr/Tp	1.670
Unit peak, qp	27.21 ft <sup>3</sup> /s
Unit peak time, Tp	0.175 hours

Subsection: Unit Hydrograph Summary  
Label: Pre-Development DA-1a

Return Event: 25 years  
Storm Event: 25-Year

---

SCS Unit Hydrograph Parameters	
Unit receding limb, Tr	0.701 hours
Total unit time, Tb	0.876 hours

---

Subsection: Unit Hydrograph Summary  
 Label: Pre-Development DA-1a

Return Event: 100 years  
 Storm Event: 100-Year

Storm Event	100-Year
Return Event	100 years
Duration	24.000 hours
Depth	6.0 in
Time of Concentration (Composite)	0.263 hours
Area (User Defined)	6.310 acres

Computational Time Increment	0.035 hours
Time to Peak (Computed)	12.054 hours
Flow (Peak, Computed)	26.15 ft <sup>3</sup> /s
Output Increment	0.050 hours
Time to Flow (Peak Interpolated Output)	12.050 hours
Flow (Peak Interpolated Output)	26.09 ft <sup>3</sup> /s

Drainage Area	
SCS CN (Composite)	77.000
Area (User Defined)	6.310 acres
Maximum Retention (Pervious)	3.0 in
Maximum Retention (Pervious, 20 percent)	0.6 in

Cumulative Runoff	
Cumulative Runoff Depth (Pervious)	3.5 in
Runoff Volume (Pervious)	1.834 ac-ft

Hydrograph Volume (Area under Hydrograph curve)	
Volume	1.828 ac-ft

SCS Unit Hydrograph Parameters	
Time of Concentration (Composite)	0.263 hours
Computational Time Increment	0.035 hours
Unit Hydrograph Shape Factor	483.432
K Factor	0.749
Receding/Rising, Tr/Tp	1.670
Unit peak, qp	27.21 ft <sup>3</sup> /s
Unit peak time, Tp	0.175 hours

Subsection: Unit Hydrograph Summary  
Label: Pre-Development DA-1a

Return Event: 100 years  
Storm Event: 100-Year

---

SCS Unit Hydrograph Parameters

---

Unit receding limb, Tr	0.701 hours
Total unit time, Tb	0.876 hours

---



Subsection: Unit Hydrograph Summary  
 Label: Pre-Development DA-1b

Return Event: 1 years  
 Storm Event: 1-Year

Storm Event	1-Year
Return Event	1 years
Duration	24.000 hours
Depth	2.0 in
Time of Concentration (Composite)	0.333 hours
Area (User Defined)	3.800 acres

Computational Time Increment	0.044 hours
Time to Peak (Computed)	12.121 hours
Flow (Peak, Computed)	1.12 ft <sup>3</sup> /s
Output Increment	0.050 hours
Time to Flow (Peak Interpolated Output)	12.150 hours
Flow (Peak Interpolated Output)	1.10 ft <sup>3</sup> /s

Drainage Area	
SCS CN (Composite)	74.000
Area (User Defined)	3.800 acres
Maximum Retention (Pervious)	3.5 in
Maximum Retention (Pervious, 20 percent)	0.7 in

Cumulative Runoff	
Cumulative Runoff Depth (Pervious)	0.4 in
Runoff Volume (Pervious)	0.112 ac-ft

Hydrograph Volume (Area under Hydrograph curve)	
Volume	0.111 ac-ft

SCS Unit Hydrograph Parameters	
Time of Concentration (Composite)	0.333 hours
Computational Time Increment	0.044 hours
Unit Hydrograph Shape Factor	483.432
K Factor	0.749
Receding/Rising, Tr/Tp	1.670
Unit peak, qp	12.93 ft <sup>3</sup> /s
Unit peak time, Tp	0.222 hours

Subsection: Unit Hydrograph Summary  
Label: Pre-Development DA-1b

Return Event: 1 years  
Storm Event: 1-Year

---

SCS Unit Hydrograph Parameters	
Unit receding limb, Tr	0.888 hours
Total unit time, Tb	1.110 hours

---

Subsection: Unit Hydrograph Summary  
 Label: Pre-Development DA-1b

Return Event: 10 years  
 Storm Event: 10-Year

Storm Event	10-Year
Return Event	10 years
Duration	24.000 hours
Depth	3.8 in
Time of Concentration (Composite)	0.333 hours
Area (User Defined)	3.800 acres

Computational Time Increment	0.044 hours
Time to Peak (Computed)	12.077 hours
Flow (Peak, Computed)	5.82 ft <sup>3</sup> /s
Output Increment	0.050 hours
Time to Flow (Peak Interpolated Output)	12.100 hours
Flow (Peak Interpolated Output)	5.81 ft <sup>3</sup> /s

Drainage Area	
SCS CN (Composite)	74.000
Area (User Defined)	3.800 acres
Maximum Retention (Pervious)	3.5 in
Maximum Retention (Pervious, 20 percent)	0.7 in

Cumulative Runoff	
Cumulative Runoff Depth (Pervious)	1.5 in
Runoff Volume (Pervious)	0.469 ac-ft

Hydrograph Volume (Area under Hydrograph curve)	
Volume	0.466 ac-ft

SCS Unit Hydrograph Parameters	
Time of Concentration (Composite)	0.333 hours
Computational Time Increment	0.044 hours
Unit Hydrograph Shape Factor	483.432
K Factor	0.749
Receding/Rising, Tr/Tp	1.670
Unit peak, qp	12.93 ft <sup>3</sup> /s
Unit peak time, Tp	0.222 hours

Subsection: Unit Hydrograph Summary  
Label: Pre-Development DA-1b

Return Event: 10 years  
Storm Event: 10-Year

---

SCS Unit Hydrograph Parameters	
Unit receding limb, Tr	0.888 hours
Total unit time, Tb	1.110 hours

---

Subsection: Unit Hydrograph Summary  
 Label: Pre-Development DA-1b

Return Event: 25 years  
 Storm Event: 25-Year

Storm Event	25-Year
Return Event	25 years
Duration	24.000 hours
Depth	4.7 in
Time of Concentration (Composite)	0.333 hours
Area (User Defined)	3.800 acres

Computational Time Increment	0.044 hours
Time to Peak (Computed)	12.077 hours
Flow (Peak, Computed)	8.53 ft <sup>3</sup> /s
Output Increment	0.050 hours
Time to Flow (Peak Interpolated Output)	12.100 hours
Flow (Peak Interpolated Output)	8.49 ft <sup>3</sup> /s

Drainage Area	
SCS CN (Composite)	74.000
Area (User Defined)	3.800 acres
Maximum Retention (Pervious)	3.5 in
Maximum Retention (Pervious, 20 percent)	0.7 in

Cumulative Runoff	
Cumulative Runoff Depth (Pervious)	2.1 in
Runoff Volume (Pervious)	0.674 ac-ft

Hydrograph Volume (Area under Hydrograph curve)	
Volume	0.670 ac-ft

SCS Unit Hydrograph Parameters	
Time of Concentration (Composite)	0.333 hours
Computational Time Increment	0.044 hours
Unit Hydrograph Shape Factor	483.432
K Factor	0.749
Receding/Rising, Tr/Tp	1.670
Unit peak, qp	12.93 ft <sup>3</sup> /s
Unit peak time, Tp	0.222 hours

Subsection: Unit Hydrograph Summary  
Label: Pre-Development DA-1b

Return Event: 25 years  
Storm Event: 25-Year

---

SCS Unit Hydrograph Parameters	
Unit receding limb, Tr	0.888 hours
Total unit time, Tb	1.110 hours

---

Subsection: Unit Hydrograph Summary  
 Label: Pre-Development DA-1b

Return Event: 100 years  
 Storm Event: 100-Year

Storm Event	100-Year
Return Event	100 years
Duration	24.000 hours
Depth	6.0 in
Time of Concentration (Composite)	0.333 hours
Area (User Defined)	3.800 acres

Computational Time Increment	0.044 hours
Time to Peak (Computed)	12.077 hours
Flow (Peak, Computed)	12.94 ft <sup>3</sup> /s
Output Increment	0.050 hours
Time to Flow (Peak Interpolated Output)	12.100 hours
Flow (Peak Interpolated Output)	12.82 ft <sup>3</sup> /s

Drainage Area	
SCS CN (Composite)	74.000
Area (User Defined)	3.800 acres
Maximum Retention (Pervious)	3.5 in
Maximum Retention (Pervious, 20 percent)	0.7 in

Cumulative Runoff	
Cumulative Runoff Depth (Pervious)	3.2 in
Runoff Volume (Pervious)	1.011 ac-ft

Hydrograph Volume (Area under Hydrograph curve)	
Volume	1.006 ac-ft

SCS Unit Hydrograph Parameters	
Time of Concentration (Composite)	0.333 hours
Computational Time Increment	0.044 hours
Unit Hydrograph Shape Factor	483.432
K Factor	0.749
Receding/Rising, Tr/Tp	1.670
Unit peak, qp	12.93 ft <sup>3</sup> /s
Unit peak time, Tp	0.222 hours

Subsection: Unit Hydrograph Summary  
Label: Pre-Development DA-1b

Return Event: 100 years  
Storm Event: 100-Year

---

SCS Unit Hydrograph Parameters	
Unit receding limb, Tr	0.888 hours
Total unit time, Tb	1.110 hours

---



Subsection: Unit Hydrograph Summary  
 Label: Pre-Development DA-2

Return Event: 1 years  
 Storm Event: 1-Year

Storm Event	1-Year
Return Event	1 years
Duration	24.000 hours
Depth	2.0 in
Time of Concentration (Composite)	0.167 hours
Area (User Defined)	4.450 acres

Computational Time Increment	0.022 hours
Time to Peak (Computed)	12.024 hours
Flow (Peak, Computed)	2.54 ft <sup>3</sup> /s
Output Increment	0.050 hours
Time to Flow (Peak Interpolated Output)	12.000 hours
Flow (Peak Interpolated Output)	2.47 ft <sup>3</sup> /s

Drainage Area	
SCS CN (Composite)	77.000
Area (User Defined)	4.450 acres
Maximum Retention (Pervious)	3.0 in
Maximum Retention (Pervious, 20 percent)	0.6 in

Cumulative Runoff	
Cumulative Runoff Depth (Pervious)	0.5 in
Runoff Volume (Pervious)	0.168 ac-ft

Hydrograph Volume (Area under Hydrograph curve)	
Volume	0.168 ac-ft

SCS Unit Hydrograph Parameters	
Time of Concentration (Composite)	0.167 hours
Computational Time Increment	0.022 hours
Unit Hydrograph Shape Factor	483.432
K Factor	0.749
Receding/Rising, Tr/Tp	1.670
Unit peak, qp	30.19 ft <sup>3</sup> /s
Unit peak time, Tp	0.111 hours

Subsection: Unit Hydrograph Summary  
Label: Pre-Development DA-2

Return Event: 1 years  
Storm Event: 1-Year

---

SCS Unit Hydrograph Parameters	
Unit receding limb, Tr	0.445 hours
Total unit time, Tb	0.557 hours

---

Subsection: Unit Hydrograph Summary  
 Label: Pre-Development DA-2

Return Event: 10 years  
 Storm Event: 10-Year

Storm Event	10-Year
Return Event	10 years
Duration	24.000 hours
Depth	3.8 in
Time of Concentration (Composite)	0.167 hours
Area (User Defined)	4.450 acres

Computational Time Increment	0.022 hours
Time to Peak (Computed)	12.002 hours
Flow (Peak, Computed)	10.28 ft <sup>3</sup> /s
Output Increment	0.050 hours
Time to Flow (Peak Interpolated Output)	12.000 hours
Flow (Peak Interpolated Output)	10.27 ft <sup>3</sup> /s

Drainage Area	
SCS CN (Composite)	77.000
Area (User Defined)	4.450 acres
Maximum Retention (Pervious)	3.0 in
Maximum Retention (Pervious, 20 percent)	0.6 in

Cumulative Runoff	
Cumulative Runoff Depth (Pervious)	1.7 in
Runoff Volume (Pervious)	0.626 ac-ft

Hydrograph Volume (Area under Hydrograph curve)	
Volume	0.624 ac-ft

SCS Unit Hydrograph Parameters	
Time of Concentration (Composite)	0.167 hours
Computational Time Increment	0.022 hours
Unit Hydrograph Shape Factor	483.432
K Factor	0.749
Receding/Rising, Tr/Tp	1.670
Unit peak, qp	30.19 ft <sup>3</sup> /s
Unit peak time, Tp	0.111 hours

Subsection: Unit Hydrograph Summary  
Label: Pre-Development DA-2

Return Event: 10 years  
Storm Event: 10-Year

---

SCS Unit Hydrograph Parameters	
Unit receding limb, Tr	0.445 hours
Total unit time, Tb	0.557 hours

---

Subsection: Unit Hydrograph Summary  
 Label: Pre-Development DA-2

Return Event: 25 years  
 Storm Event: 25-Year

Storm Event	25-Year
Return Event	25 years
Duration	24.000 hours
Depth	4.7 in
Time of Concentration (Composite)	0.167 hours
Area (User Defined)	4.450 acres

Computational Time Increment	0.022 hours
Time to Peak (Computed)	12.002 hours
Flow (Peak, Computed)	14.47 ft <sup>3</sup> /s
Output Increment	0.050 hours
Time to Flow (Peak Interpolated Output)	12.000 hours
Flow (Peak Interpolated Output)	14.46 ft <sup>3</sup> /s

Drainage Area	
SCS CN (Composite)	77.000
Area (User Defined)	4.450 acres
Maximum Retention (Pervious)	3.0 in
Maximum Retention (Pervious, 20 percent)	0.6 in

Cumulative Runoff	
Cumulative Runoff Depth (Pervious)	2.4 in
Runoff Volume (Pervious)	0.880 ac-ft

Hydrograph Volume (Area under Hydrograph curve)	
Volume	0.878 ac-ft

SCS Unit Hydrograph Parameters	
Time of Concentration (Composite)	0.167 hours
Computational Time Increment	0.022 hours
Unit Hydrograph Shape Factor	483.432
K Factor	0.749
Receding/Rising, Tr/Tp	1.670
Unit peak, qp	30.19 ft <sup>3</sup> /s
Unit peak time, Tp	0.111 hours

Subsection: Unit Hydrograph Summary  
Label: Pre-Development DA-2

Return Event: 25 years  
Storm Event: 25-Year

---

SCS Unit Hydrograph Parameters	
Unit receding limb, Tr	0.445 hours
Total unit time, Tb	0.557 hours

---

Subsection: Unit Hydrograph Summary  
 Label: Pre-Development DA-2

Return Event: 100 years  
 Storm Event: 100-Year

Storm Event	100-Year
Return Event	100 years
Duration	24.000 hours
Depth	6.0 in
Time of Concentration (Composite)	0.167 hours
Area (User Defined)	4.450 acres
<hr/>	
Computational Time Increment	0.022 hours
Time to Peak (Computed)	11.979 hours
Flow (Peak, Computed)	21.15 ft <sup>3</sup> /s
Output Increment	0.050 hours
Time to Flow (Peak Interpolated Output)	12.000 hours
Flow (Peak Interpolated Output)	21.12 ft <sup>3</sup> /s
<hr/>	
Drainage Area	
SCS CN (Composite)	77.000
Area (User Defined)	4.450 acres
Maximum Retention (Pervious)	3.0 in
Maximum Retention (Pervious, 20 percent)	0.6 in
<hr/>	
Cumulative Runoff	
Cumulative Runoff Depth (Pervious)	3.5 in
Runoff Volume (Pervious)	1.293 ac-ft
<hr/>	
Hydrograph Volume (Area under Hydrograph curve)	
Volume	1.291 ac-ft
<hr/>	
SCS Unit Hydrograph Parameters	
Time of Concentration (Composite)	0.167 hours
Computational Time Increment	0.022 hours
Unit Hydrograph Shape Factor	483.432
K Factor	0.749
Receding/Rising, Tr/Tp	1.670
Unit peak, qp	30.19 ft <sup>3</sup> /s
Unit peak time, Tp	0.111 hours

Subsection: Unit Hydrograph Summary  
Label: Pre-Development DA-2

Return Event: 100 years  
Storm Event: 100-Year

---

SCS Unit Hydrograph Parameters	
Unit receding limb, Tr	0.445 hours
Total unit time, Tb	0.557 hours

---



Subsection: Unit Hydrograph Summary  
 Label: Pre-Development DA-2 Offsite

Return Event: 1 years  
 Storm Event: 1-Year

Storm Event	1-Year
Return Event	1 years
Duration	24.000 hours
Depth	2.0 in
Time of Concentration (Composite)	0.600 hours
Area (User Defined)	108.040 acres

Computational Time Increment	0.080 hours
Time to Peak (Computed)	12.320 hours
Flow (Peak, Computed)	33.91 ft <sup>3</sup> /s
Output Increment	0.050 hours
Time to Flow (Peak Interpolated Output)	12.300 hours
Flow (Peak Interpolated Output)	33.86 ft <sup>3</sup> /s

Drainage Area	
SCS CN (Composite)	78.000
Area (User Defined)	108.040 acres
Maximum Retention (Pervious)	2.8 in
Maximum Retention (Pervious, 20 percent)	0.6 in

Cumulative Runoff	
Cumulative Runoff Depth (Pervious)	0.5 in
Runoff Volume (Pervious)	4.412 ac-ft

Hydrograph Volume (Area under Hydrograph curve)	
Volume	4.358 ac-ft

SCS Unit Hydrograph Parameters	
Time of Concentration (Composite)	0.600 hours
Computational Time Increment	0.080 hours
Unit Hydrograph Shape Factor	483.432
K Factor	0.749
Receding/Rising, Tr/Tp	1.670
Unit peak, qp	204.02 ft <sup>3</sup> /s
Unit peak time, Tp	0.400 hours

Subsection: Unit Hydrograph Summary  
Label: Pre-Development DA-2 Offsite

Return Event: 1 years  
Storm Event: 1-Year

---

SCS Unit Hydrograph Parameters	
Unit receding limb, Tr	1.600 hours
Total unit time, Tb	2.000 hours

---

Subsection: Unit Hydrograph Summary  
 Label: Pre-Development DA-2 Offsite

Return Event: 10 years  
 Storm Event: 10-Year

Storm Event	10-Year
Return Event	10 years
Duration	24.000 hours
Depth	3.8 in
Time of Concentration (Composite)	0.600 hours
Area (User Defined)	108.040 acres

Computational Time Increment	0.080 hours
Time to Peak (Computed)	12.240 hours
Flow (Peak, Computed)	142.70 ft <sup>3</sup> /s
Output Increment	0.050 hours
Time to Flow (Peak Interpolated Output)	12.250 hours
Flow (Peak Interpolated Output)	142.00 ft <sup>3</sup> /s

Drainage Area	
SCS CN (Composite)	78.000
Area (User Defined)	108.040 acres
Maximum Retention (Pervious)	2.8 in
Maximum Retention (Pervious, 20 percent)	0.6 in

Cumulative Runoff	
Cumulative Runoff Depth (Pervious)	1.8 in
Runoff Volume (Pervious)	15.849 ac-ft

Hydrograph Volume (Area under Hydrograph curve)	
Volume	15.704 ac-ft

SCS Unit Hydrograph Parameters	
Time of Concentration (Composite)	0.600 hours
Computational Time Increment	0.080 hours
Unit Hydrograph Shape Factor	483.432
K Factor	0.749
Receding/Rising, Tr/Tp	1.670
Unit peak, qp	204.02 ft <sup>3</sup> /s
Unit peak time, Tp	0.400 hours

Subsection: Unit Hydrograph Summary  
Label: Pre-Development DA-2 Offsite

Return Event: 10 years  
Storm Event: 10-Year

---

SCS Unit Hydrograph Parameters	
Unit receding limb, Tr	1.600 hours
Total unit time, Tb	2.000 hours

---

Subsection: Unit Hydrograph Summary  
 Label: Pre-Development DA-2 Offsite

Return Event: 25 years  
 Storm Event: 25-Year

Storm Event	25-Year
Return Event	25 years
Duration	24.000 hours
Depth	4.7 in
Time of Concentration (Composite)	0.600 hours
Area (User Defined)	108.040 acres

Computational Time Increment	0.080 hours
Time to Peak (Computed)	12.240 hours
Flow (Peak, Computed)	201.74 ft <sup>3</sup> /s
Output Increment	0.050 hours
Time to Flow (Peak Interpolated Output)	12.250 hours
Flow (Peak Interpolated Output)	200.59 ft <sup>3</sup> /s

Drainage Area	
SCS CN (Composite)	78.000
Area (User Defined)	108.040 acres
Maximum Retention (Pervious)	2.8 in
Maximum Retention (Pervious, 20 percent)	0.6 in

Cumulative Runoff	
Cumulative Runoff Depth (Pervious)	2.5 in
Runoff Volume (Pervious)	22.139 ac-ft

Hydrograph Volume (Area under Hydrograph curve)	
Volume	21.951 ac-ft

SCS Unit Hydrograph Parameters	
Time of Concentration (Composite)	0.600 hours
Computational Time Increment	0.080 hours
Unit Hydrograph Shape Factor	483.432
K Factor	0.749
Receding/Rising, Tr/Tp	1.670
Unit peak, qp	204.02 ft <sup>3</sup> /s
Unit peak time, Tp	0.400 hours

Subsection: Unit Hydrograph Summary  
Label: Pre-Development DA-2 Offsite

Return Event: 25 years  
Storm Event: 25-Year

---

SCS Unit Hydrograph Parameters	
Unit receding limb, Tr	1.600 hours
Total unit time, Tb	2.000 hours

---

Subsection: Unit Hydrograph Summary  
 Label: Pre-Development DA-2 Offsite

Return Event: 100 years  
 Storm Event: 100-Year

Storm Event	100-Year
Return Event	100 years
Duration	24.000 hours
Depth	6.0 in
Time of Concentration (Composite)	0.600 hours
Area (User Defined)	108.040 acres

Computational Time Increment	0.080 hours
Time to Peak (Computed)	12.240 hours
Flow (Peak, Computed)	295.74 ft <sup>3</sup> /s
Output Increment	0.050 hours
Time to Flow (Peak Interpolated Output)	12.250 hours
Flow (Peak Interpolated Output)	293.80 ft <sup>3</sup> /s

Drainage Area	
SCS CN (Composite)	78.000
Area (User Defined)	108.040 acres
Maximum Retention (Pervious)	2.8 in
Maximum Retention (Pervious, 20 percent)	0.6 in

Cumulative Runoff	
Cumulative Runoff Depth (Pervious)	3.6 in
Runoff Volume (Pervious)	32.302 ac-ft

Hydrograph Volume (Area under Hydrograph curve)	
Volume	32.047 ac-ft

SCS Unit Hydrograph Parameters	
Time of Concentration (Composite)	0.600 hours
Computational Time Increment	0.080 hours
Unit Hydrograph Shape Factor	483.432
K Factor	0.749
Receding/Rising, Tr/Tp	1.670
Unit peak, qp	204.02 ft <sup>3</sup> /s
Unit peak time, Tp	0.400 hours

Subsection: Unit Hydrograph Summary  
Label: Pre-Development DA-2 Offsite

Return Event: 100 years  
Storm Event: 100-Year

---

SCS Unit Hydrograph Parameters	
Unit receding limb, Tr	1.600 hours
Total unit time, Tb	2.000 hours

---



Subsection: Unit Hydrograph Summary  
 Label: Pre-Development DA-3

Return Event: 1 years  
 Storm Event: 1-Year

Storm Event	1-Year
Return Event	1 years
Duration	24.000 hours
Depth	2.0 in
Time of Concentration (Composite)	0.250 hours
Area (User Defined)	5.800 acres
<hr/>	
Computational Time Increment	0.033 hours
Time to Peak (Computed)	12.067 hours
Flow (Peak, Computed)	2.85 ft <sup>3</sup> /s
Output Increment	0.050 hours
Time to Flow (Peak Interpolated Output)	12.050 hours
Flow (Peak Interpolated Output)	2.79 ft <sup>3</sup> /s
<hr/>	
Drainage Area	
SCS CN (Composite)	77.000
Area (User Defined)	5.800 acres
Maximum Retention (Pervious)	3.0 in
Maximum Retention (Pervious, 20 percent)	0.6 in
<hr/>	
Cumulative Runoff	
Cumulative Runoff Depth (Pervious)	0.5 in
Runoff Volume (Pervious)	0.219 ac-ft
<hr/>	
Hydrograph Volume (Area under Hydrograph curve)	
Volume	0.218 ac-ft
<hr/>	
SCS Unit Hydrograph Parameters	
Time of Concentration (Composite)	0.250 hours
Computational Time Increment	0.033 hours
Unit Hydrograph Shape Factor	483.432
K Factor	0.749
Receding/Rising, Tr/Tp	1.670
Unit peak, qp	26.29 ft <sup>3</sup> /s
Unit peak time, Tp	0.167 hours

Subsection: Unit Hydrograph Summary  
Label: Pre-Development DA-3

Return Event: 1 years  
Storm Event: 1-Year

---

SCS Unit Hydrograph Parameters	
Unit receding limb, Tr	0.667 hours
Total unit time, Tb	0.833 hours

---

Subsection: Unit Hydrograph Summary  
 Label: Pre-Development DA-3

Return Event: 10 years  
 Storm Event: 10-Year

Storm Event	10-Year
Return Event	10 years
Duration	24.000 hours
Depth	3.8 in
Time of Concentration (Composite)	0.250 hours
Area (User Defined)	5.800 acres

Computational Time Increment	0.033 hours
Time to Peak (Computed)	12.033 hours
Flow (Peak, Computed)	11.81 ft <sup>3</sup> /s
Output Increment	0.050 hours
Time to Flow (Peak Interpolated Output)	12.050 hours
Flow (Peak Interpolated Output)	11.81 ft <sup>3</sup> /s

Drainage Area	
SCS CN (Composite)	77.000
Area (User Defined)	5.800 acres
Maximum Retention (Pervious)	3.0 in
Maximum Retention (Pervious, 20 percent)	0.6 in

Cumulative Runoff	
Cumulative Runoff Depth (Pervious)	1.7 in
Runoff Volume (Pervious)	0.816 ac-ft

Hydrograph Volume (Area under Hydrograph curve)	
Volume	0.813 ac-ft

SCS Unit Hydrograph Parameters	
Time of Concentration (Composite)	0.250 hours
Computational Time Increment	0.033 hours
Unit Hydrograph Shape Factor	483.432
K Factor	0.749
Receding/Rising, Tr/Tp	1.670
Unit peak, qp	26.29 ft <sup>3</sup> /s
Unit peak time, Tp	0.167 hours

Subsection: Unit Hydrograph Summary  
Label: Pre-Development DA-3

Return Event: 10 years  
Storm Event: 10-Year

---

SCS Unit Hydrograph Parameters	
Unit receding limb, Tr	0.667 hours
Total unit time, Tb	0.833 hours

---

Subsection: Unit Hydrograph Summary  
 Label: Pre-Development DA-3

Return Event: 25 years  
 Storm Event: 25-Year

Storm Event	25-Year
Return Event	25 years
Duration	24.000 hours
Depth	4.7 in
Time of Concentration (Composite)	0.250 hours
Area (User Defined)	5.800 acres
<hr/>	
Computational Time Increment	0.033 hours
Time to Peak (Computed)	12.033 hours
Flow (Peak, Computed)	16.75 ft <sup>3</sup> /s
Output Increment	0.050 hours
Time to Flow (Peak Interpolated Output)	12.050 hours
Flow (Peak Interpolated Output)	16.68 ft <sup>3</sup> /s
<hr/>	
Drainage Area	
SCS CN (Composite)	77.000
Area (User Defined)	5.800 acres
Maximum Retention (Pervious)	3.0 in
Maximum Retention (Pervious, 20 percent)	0.6 in
<hr/>	
Cumulative Runoff	
Cumulative Runoff Depth (Pervious)	2.4 in
Runoff Volume (Pervious)	1.147 ac-ft
<hr/>	
Hydrograph Volume (Area under Hydrograph curve)	
Volume	1.143 ac-ft
<hr/>	
SCS Unit Hydrograph Parameters	
Time of Concentration (Composite)	0.250 hours
Computational Time Increment	0.033 hours
Unit Hydrograph Shape Factor	483.432
K Factor	0.749
Receding/Rising, Tr/Tp	1.670
Unit peak, qp	26.29 ft <sup>3</sup> /s
Unit peak time, Tp	0.167 hours

Subsection: Unit Hydrograph Summary  
Label: Pre-Development DA-3

Return Event: 25 years  
Storm Event: 25-Year

---

SCS Unit Hydrograph Parameters	
Unit receding limb, Tr	0.667 hours
Total unit time, Tb	0.833 hours

---

Subsection: Unit Hydrograph Summary  
 Label: Pre-Development DA-3

Return Event: 100 years  
 Storm Event: 100-Year

Storm Event	100-Year
Return Event	100 years
Duration	24.000 hours
Depth	6.0 in
Time of Concentration (Composite)	0.250 hours
Area (User Defined)	5.800 acres
<hr/>	
Computational Time Increment	0.033 hours
Time to Peak (Computed)	12.033 hours
Flow (Peak, Computed)	24.61 ft <sup>3</sup> /s
Output Increment	0.050 hours
Time to Flow (Peak Interpolated Output)	12.050 hours
Flow (Peak Interpolated Output)	24.44 ft <sup>3</sup> /s
<hr/>	
Drainage Area	
SCS CN (Composite)	77.000
Area (User Defined)	5.800 acres
Maximum Retention (Pervious)	3.0 in
Maximum Retention (Pervious, 20 percent)	0.6 in
<hr/>	
Cumulative Runoff	
Cumulative Runoff Depth (Pervious)	3.5 in
Runoff Volume (Pervious)	1.686 ac-ft
<hr/>	
Hydrograph Volume (Area under Hydrograph curve)	
Volume	1.680 ac-ft
<hr/>	
SCS Unit Hydrograph Parameters	
Time of Concentration (Composite)	0.250 hours
Computational Time Increment	0.033 hours
Unit Hydrograph Shape Factor	483.432
K Factor	0.749
Receding/Rising, Tr/Tp	1.670
Unit peak, qp	26.29 ft <sup>3</sup> /s
Unit peak time, Tp	0.167 hours

Subsection: Unit Hydrograph Summary  
Label: Pre-Development DA-3

Return Event: 100 years  
Storm Event: 100-Year

---

SCS Unit Hydrograph Parameters	
Unit receding limb, Tr	0.667 hours
Total unit time, Tb	0.833 hours

---



Subsection: Unit Hydrograph Summary  
 Label: Pre-Development DA-3 Offsite

Return Event: 1 years  
 Storm Event: 1-Year

Storm Event	1-Year
Return Event	1 years
Duration	24.000 hours
Depth	2.0 in
Time of Concentration (Composite)	0.400 hours
Area (User Defined)	6.130 acres

Computational Time Increment	0.053 hours
Time to Peak (Computed)	12.160 hours
Flow (Peak, Computed)	2.56 ft <sup>3</sup> /s
Output Increment	0.050 hours
Time to Flow (Peak Interpolated Output)	12.150 hours
Flow (Peak Interpolated Output)	2.54 ft <sup>3</sup> /s

Drainage Area	
SCS CN (Composite)	78.000
Area (User Defined)	6.130 acres
Maximum Retention (Pervious)	2.8 in
Maximum Retention (Pervious, 20 percent)	0.6 in

Cumulative Runoff	
Cumulative Runoff Depth (Pervious)	0.5 in
Runoff Volume (Pervious)	0.250 ac-ft

Hydrograph Volume (Area under Hydrograph curve)	
Volume	0.248 ac-ft

SCS Unit Hydrograph Parameters	
Time of Concentration (Composite)	0.400 hours
Computational Time Increment	0.053 hours
Unit Hydrograph Shape Factor	483.432
K Factor	0.749
Receding/Rising, Tr/Tp	1.670
Unit peak, qp	17.36 ft <sup>3</sup> /s
Unit peak time, Tp	0.267 hours

Subsection: Unit Hydrograph Summary  
Label: Pre-Development DA-3 Offsite

Return Event: 1 years  
Storm Event: 1-Year

---

SCS Unit Hydrograph Parameters	
Unit receding limb, Tr	1.067 hours
Total unit time, Tb	1.333 hours

---

Subsection: Unit Hydrograph Summary  
 Label: Pre-Development DA-3 Offsite

Return Event: 10 years  
 Storm Event: 10-Year

Storm Event	10-Year
Return Event	10 years
Duration	24.000 hours
Depth	3.8 in
Time of Concentration (Composite)	0.400 hours
Area (User Defined)	6.130 acres

Computational Time Increment	0.053 hours
Time to Peak (Computed)	12.107 hours
Flow (Peak, Computed)	10.34 ft <sup>3</sup> /s
Output Increment	0.050 hours
Time to Flow (Peak Interpolated Output)	12.150 hours
Flow (Peak Interpolated Output)	10.30 ft <sup>3</sup> /s

Drainage Area	
SCS CN (Composite)	78.000
Area (User Defined)	6.130 acres
Maximum Retention (Pervious)	2.8 in
Maximum Retention (Pervious, 20 percent)	0.6 in

Cumulative Runoff	
Cumulative Runoff Depth (Pervious)	1.8 in
Runoff Volume (Pervious)	0.899 ac-ft

Hydrograph Volume (Area under Hydrograph curve)	
Volume	0.894 ac-ft

SCS Unit Hydrograph Parameters	
Time of Concentration (Composite)	0.400 hours
Computational Time Increment	0.053 hours
Unit Hydrograph Shape Factor	483.432
K Factor	0.749
Receding/Rising, Tr/Tp	1.670
Unit peak, qp	17.36 ft <sup>3</sup> /s
Unit peak time, Tp	0.267 hours

Subsection: Unit Hydrograph Summary  
Label: Pre-Development DA-3 Offsite

Return Event: 10 years  
Storm Event: 10-Year

---

SCS Unit Hydrograph Parameters	
Unit receding limb, Tr	1.067 hours
Total unit time, Tb	1.333 hours

---

Subsection: Unit Hydrograph Summary  
 Label: Pre-Development DA-3 Offsite

Return Event: 25 years  
 Storm Event: 25-Year

Storm Event	25-Year
Return Event	25 years
Duration	24.000 hours
Depth	4.7 in
Time of Concentration (Composite)	0.400 hours
Area (User Defined)	6.130 acres
<hr/>	
Computational Time Increment	0.053 hours
Time to Peak (Computed)	12.107 hours
Flow (Peak, Computed)	14.60 ft <sup>3</sup> /s
Output Increment	0.050 hours
Time to Flow (Peak Interpolated Output)	12.150 hours
Flow (Peak Interpolated Output)	14.46 ft <sup>3</sup> /s
<hr/>	
Drainage Area	
SCS CN (Composite)	78.000
Area (User Defined)	6.130 acres
Maximum Retention (Pervious)	2.8 in
Maximum Retention (Pervious, 20 percent)	0.6 in
<hr/>	
Cumulative Runoff	
Cumulative Runoff Depth (Pervious)	2.5 in
Runoff Volume (Pervious)	1.256 ac-ft
<hr/>	
Hydrograph Volume (Area under Hydrograph curve)	
Volume	1.250 ac-ft
<hr/>	
SCS Unit Hydrograph Parameters	
Time of Concentration (Composite)	0.400 hours
Computational Time Increment	0.053 hours
Unit Hydrograph Shape Factor	483.432
K Factor	0.749
Receding/Rising, Tr/Tp	1.670
Unit peak, qp	17.36 ft <sup>3</sup> /s
Unit peak time, Tp	0.267 hours

Subsection: Unit Hydrograph Summary  
Label: Pre-Development DA-3 Offsite

Return Event: 25 years  
Storm Event: 25-Year

---

SCS Unit Hydrograph Parameters

---

Unit receding limb, Tr	1.067 hours
Total unit time, Tb	1.333 hours

---

Subsection: Unit Hydrograph Summary  
 Label: Pre-Development DA-3 Offsite

Return Event: 100 years  
 Storm Event: 100-Year

Storm Event	100-Year
Return Event	100 years
Duration	24.000 hours
Depth	6.0 in
Time of Concentration (Composite)	0.400 hours
Area (User Defined)	6.130 acres

Computational Time Increment	0.053 hours
Time to Peak (Computed)	12.107 hours
Flow (Peak, Computed)	21.38 ft <sup>3</sup> /s
Output Increment	0.050 hours
Time to Flow (Peak Interpolated Output)	12.100 hours
Flow (Peak Interpolated Output)	21.18 ft <sup>3</sup> /s

Drainage Area	
SCS CN (Composite)	78.000
Area (User Defined)	6.130 acres
Maximum Retention (Pervious)	2.8 in
Maximum Retention (Pervious, 20 percent)	0.6 in

Cumulative Runoff	
Cumulative Runoff Depth (Pervious)	3.6 in
Runoff Volume (Pervious)	1.833 ac-ft

Hydrograph Volume (Area under Hydrograph curve)	
Volume	1.824 ac-ft

SCS Unit Hydrograph Parameters	
Time of Concentration (Composite)	0.400 hours
Computational Time Increment	0.053 hours
Unit Hydrograph Shape Factor	483.432
K Factor	0.749
Receding/Rising, Tr/Tp	1.670
Unit peak, qp	17.36 ft <sup>3</sup> /s
Unit peak time, Tp	0.267 hours

Subsection: Unit Hydrograph Summary  
Label: Pre-Development DA-3 Offsite

Return Event: 100 years  
Storm Event: 100-Year

---

SCS Unit Hydrograph Parameters	
Unit receding limb, Tr	1.067 hours
Total unit time, Tb	1.333 hours

---



# Index

## I

- Ithaca (Time-Depth Curve, 1 years)...8, 9
- Ithaca (Time-Depth Curve, 10 years)...6, 7
- Ithaca (Time-Depth Curve, 100 years)...4, 5
- Ithaca (Time-Depth Curve, 25 years)...10, 11

## M

- Master Network Summary...2, 3

## P

- Pre-Development DA-1 Offsite (Unit Hydrograph Summary, 1 years)...18, 19
- Pre-Development DA-1 Offsite (Unit Hydrograph Summary, 10 years)...20, 21
- Pre-Development DA-1 Offsite (Unit Hydrograph Summary, 100 years)...24, 25
- Pre-Development DA-1 Offsite (Unit Hydrograph Summary, 25 years)...22, 23
- Pre-Development DA-1a (Runoff CN-Area, 1 years)...14
- Pre-Development DA-1a (Time of Concentration Calculations, 1 years)...12, 13
- Pre-Development DA-1a (Unit Hydrograph Summary, 1 years)...26, 27
- Pre-Development DA-1a (Unit Hydrograph Summary, 10 years)...28, 29
- Pre-Development DA-1a (Unit Hydrograph Summary, 100 years)...32, 33
- Pre-Development DA-1a (Unit Hydrograph Summary, 25 years)...30, 31
- Pre-Development DA-1b (Runoff CN-Area, 1 years)...15
- Pre-Development DA-1b (Unit Hydrograph Summary, 1 years)...34, 35
- Pre-Development DA-1b (Unit Hydrograph Summary, 10 years)...36, 37
- Pre-Development DA-1b (Unit Hydrograph Summary, 100 years)...40, 41
- Pre-Development DA-1b (Unit Hydrograph Summary, 25 years)...38, 39
- Pre-Development DA-2 (Runoff CN-Area, 1 years)...16
- Pre-Development DA-2 (Unit Hydrograph Summary, 1 years)...42, 43
- Pre-Development DA-2 (Unit Hydrograph Summary, 10 years)...44, 45
- Pre-Development DA-2 (Unit Hydrograph Summary, 100 years)...48, 49
- Pre-Development DA-2 (Unit Hydrograph Summary, 25 years)...46, 47
- Pre-Development DA-2 Offsite (Unit Hydrograph Summary, 1 years)...50, 51
- Pre-Development DA-2 Offsite (Unit Hydrograph Summary, 10 years)...52, 53
- Pre-Development DA-2 Offsite (Unit Hydrograph Summary, 100 years)...56, 57

Pre-Development DA-2 Offsite (Unit Hydrograph Summary, 25 years)...54, 55  
Pre-Development DA-3 (Runoff CN-Area, 1 years)...17  
Pre-Development DA-3 (Unit Hydrograph Summary, 1 years)...58, 59  
Pre-Development DA-3 (Unit Hydrograph Summary, 10 years)...60, 61  
Pre-Development DA-3 (Unit Hydrograph Summary, 100 years)...64, 65  
Pre-Development DA-3 (Unit Hydrograph Summary, 25 years)...62, 63  
Pre-Development DA-3 Offsite (Unit Hydrograph Summary, 1 years)...66, 67  
Pre-Development DA-3 Offsite (Unit Hydrograph Summary, 10 years)...68, 69  
Pre-Development DA-3 Offsite (Unit Hydrograph Summary, 100 years)...72, 73  
Pre-Development DA-3 Offsite (Unit Hydrograph Summary, 25 years)...70, 71

---

Project Summary

---

Title

Engineer

Company

Date 3/8/2019

---

---

Notes

---

## Table of Contents

	Master Network Summary	2
Ithaca	100-Year	
	Time-Depth Curve	6
	Time-Depth Curve	8
	Time-Depth Curve	10
	Time-Depth Curve	12
	Unit Hydrograph Equations	14
Post-Development DA-1	1-Year	
	Unit Hydrograph Summary	16
	Unit Hydrograph Summary	18
	Unit Hydrograph Summary	20
	Unit Hydrograph Summary	22
Post-Development DA-1 Bypass	1-Year	
	Unit Hydrograph Summary	24
	Unit Hydrograph Summary	26
	Unit Hydrograph Summary	28
	Unit Hydrograph Summary	30
Post-Development DA-1 Offsite	1-Year	
	Unit Hydrograph Summary	32
	Unit Hydrograph Summary	34
	Unit Hydrograph Summary	36
	Unit Hydrograph Summary	38
Post-Development DA-2	1-Year	
	Unit Hydrograph Summary	40
	Unit Hydrograph Summary	42
	Unit Hydrograph Summary	44
	Unit Hydrograph Summary	46
Post-Development DA-2 Bypass	1-Year	
	Unit Hydrograph Summary	48

## Table of Contents

	Unit Hydrograph Summary	50
	Unit Hydrograph Summary	52
	Unit Hydrograph Summary	54
Post-Development DA-2 Offsite	1-Year	
	Unit Hydrograph Summary	56
	Unit Hydrograph Summary	58
	Unit Hydrograph Summary	60
	Unit Hydrograph Summary	62
Post-Development DA-3	1-Year	
	Unit Hydrograph Summary	64
	Unit Hydrograph Summary	66
	Unit Hydrograph Summary	68
	Unit Hydrograph Summary	70
Post-Development DA-3 Bypass	1-Year	
	Unit Hydrograph Summary	72
	Unit Hydrograph Summary	74
	Unit Hydrograph Summary	76
	Unit Hydrograph Summary	78
Post-Development DA-3 Offsite	1-Year	
	Unit Hydrograph Summary	80
	Unit Hydrograph Summary	82
	Unit Hydrograph Summary	84
	Unit Hydrograph Summary	86

Subsection: Master Network Summary

**Catchments Summary**

Label	Scenario	Return Event (years)	Hydrograph Volume (ac-ft)	Time to Peak (hours)	Peak Flow (ft <sup>3</sup> /s)
Post-Development DA-2	Post-Development 1-Year	1	0.721	11.950	12.99
Post-Development DA-2	Post-Development 10-Year	10	1.811	11.950	31.48
Post-Development DA-2	Post-Development 25-Year	25	2.347	11.950	40.20
Post-Development DA-2	Post-Development 100-Year	100	3.183	11.950	53.49
Post-Development DA-3	Post-Development 1-Year	1	0.146	11.900	2.65
Post-Development DA-3	Post-Development 10-Year	10	0.366	11.900	6.57
Post-Development DA-3	Post-Development 25-Year	25	0.475	11.900	8.43
Post-Development DA-3	Post-Development 100-Year	100	0.644	11.900	11.27
Post-Development DA-1	Post-Development 1-Year	1	0.220	11.950	3.97
Post-Development DA-1	Post-Development 10-Year	10	0.553	11.950	9.61
Post-Development DA-1	Post-Development 25-Year	25	0.717	11.950	12.27
Post-Development DA-1	Post-Development 100-Year	100	0.972	11.950	16.33
Post-Development DA-1 Bypass	Post-Development 1-Year	1	0.364	12.050	5.25
Post-Development DA-1 Bypass	Post-Development 10-Year	10	1.050	12.050	15.23
Post-Development DA-1 Bypass	Post-Development 25-Year	25	1.403	12.050	20.17
Post-Development DA-1 Bypass	Post-Development 100-Year	100	1.961	12.050	27.79
Post-Development DA-2 Bypass	Post-Development 1-Year	1	0.007	12.000	0.10
Post-Development DA-2 Bypass	Post-Development 10-Year	10	0.023	12.000	0.39
Post-Development DA-2 Bypass	Post-Development 25-Year	25	0.033	12.000	0.54
Post-Development DA-2 Bypass	Post-Development 100-Year	100	0.048	12.000	0.78
Post-Development DA-3 Bypass	Post-Development 1-Year	1	0.192	12.000	2.96
Post-Development DA-3 Bypass	Post-Development 10-Year	10	0.555	12.000	8.66
Post-Development DA-3 Bypass	Post-Development 25-Year	25	0.741	12.000	11.49
Post-Development DA-3 Bypass	Post-Development 100-Year	100	1.035	12.000	15.86

Subsection: Master Network Summary

**Catchments Summary**

Label	Scenario	Return Event (years)	Hydrograph Volume (ac-ft)	Time to Peak (hours)	Peak Flow (ft <sup>3</sup> /s)
Post-Development DA-1 Offsite	Post-Development 1-Year	1	0.335	12.200	3.37
Post-Development DA-1 Offsite	Post-Development 10-Year	10	0.968	12.200	9.98
Post-Development DA-1 Offsite	Post-Development 25-Year	25	1.293	12.200	13.26
Post-Development DA-1 Offsite	Post-Development 100-Year	100	1.808	12.200	18.35
Post-Development DA-2 Offsite	Post-Development 1-Year	1	4.358	12.300	33.86
Post-Development DA-2 Offsite	Post-Development 10-Year	10	15.704	12.250	142.00
Post-Development DA-2 Offsite	Post-Development 25-Year	25	21.951	12.250	200.59
Post-Development DA-2 Offsite	Post-Development 100-Year	100	32.126	12.250	294.53
Post-Development DA-3 Offsite	Post-Development 1-Year	1	0.248	12.150	2.54
Post-Development DA-3 Offsite	Post-Development 10-Year	10	0.894	12.150	10.30
Post-Development DA-3 Offsite	Post-Development 25-Year	25	1.250	12.150	14.46
Post-Development DA-3 Offsite	Post-Development 100-Year	100	1.829	12.100	21.24

**Node Summary**

Label	Scenario	Return Event (years)	Hydrograph Volume (ac-ft)	Time to Peak (hours)	Peak Flow (ft <sup>3</sup> /s)
Post-Development Outfall-3	Post-Development 1-Year	1	0.560	12.050	5.61
Post-Development Outfall-3	Post-Development 10-Year	10	1.763	12.050	18.76
Post-Development Outfall-3	Post-Development 25-Year	25	2.402	12.050	25.53
Post-Development Outfall-3	Post-Development 100-Year	100	3.430	12.050	36.19
Post-Development Outfall-1&2	Post-Development 1-Year	1	0.918	12.100	9.39
Post-Development Outfall-1&2	Post-Development 10-Year	10	2.570	12.050	25.39
Post-Development Outfall-1&2	Post-Development 25-Year	25	3.411	12.050	33.32
Post-Development Outfall-1&2	Post-Development 100-Year	100	4.739	12.050	45.58
Post-Development Outfall-2	Post-Development 1-Year	1	3.486	13.150	9.44

Subsection: Master Network Summary

**Node Summary**

Label	Scenario	Return Event (years)	Hydrograph Volume (ac-ft)	Time to Peak (hours)	Peak Flow (ft <sup>3</sup> /s)
Post-Development Outfall-2	Post-Development 10-Year	10	15.564	12.300	141.18
Post-Development Outfall-2	Post-Development 25-Year	25	22.137	12.300	200.42
Post-Development Outfall-2	Post-Development 100-Year	100	33.055	12.300	295.07

**Pond Summary**

Label	Scenario	Return Event (years)	Hydrograph Volume (ac-ft)	Time to Peak (hours)	Peak Flow (ft <sup>3</sup> /s)	Maximum Water Surface Elevation (ft)	Maximum Pond Storage (ac-ft)
Pond-2 (IN)	Post-Development 1-Year	1	5.079	12.250	35.75	(N/A)	(N/A)
Pond-2 (OUT)	Post-Development 1-Year	1	3.479	13.150	9.43	969.58	2.197
Pond-2 (IN)	Post-Development 10-Year	10	17.515	12.250	146.56	(N/A)	(N/A)
Pond-2 (OUT)	Post-Development 10-Year	10	15.540	12.300	141.10	971.03	3.100
Pond-2 (IN)	Post-Development 25-Year	25	24.298	12.250	206.34	(N/A)	(N/A)
Pond-2 (OUT)	Post-Development 25-Year	25	22.104	12.300	200.32	971.49	3.411
Pond-2 (IN)	Post-Development 100-Year	100	35.310	12.250	302.08	(N/A)	(N/A)
Pond-2 (OUT)	Post-Development 100-Year	100	33.007	12.300	294.92	972.15	3.866
Pond-3 (IN)	Post-Development 1-Year	1	0.146	11.900	2.65	(N/A)	(N/A)
Pond-3 (OUT)	Post-Development 1-Year	1	0.120	12.100	0.63	939.73	0.051
Pond-3 (IN)	Post-Development 10-Year	10	0.366	11.900	6.57	(N/A)	(N/A)



Subsection: Master Network Summary

**Pond Summary**

Label	Scenario	Return Event (years)	Hydrograph Volume (ac-ft)	Time to Peak (hours)	Peak Flow (ft <sup>3</sup> /s)	Maximum Water Surface Elevation (ft)	Maximum Pond Storage (ac-ft)
Pond-3 (OUT)	Post-Development 10-Year	10	0.314	12.150	1.16	940.77	0.141
Pond-3 (IN)	Post-Development 25-Year	25	0.475	11.900	8.43	(N/A)	(N/A)
Pond-3 (OUT)	Post-Development 25-Year	25	0.412	12.150	1.32	941.21	0.188
Pond-3 (IN)	Post-Development 100-Year	100	0.644	11.900	11.27	(N/A)	(N/A)
Pond-3 (OUT)	Post-Development 100-Year	100	0.566	12.200	1.52	941.84	0.262
Pond-1 (IN)	Post-Development 1-Year	1	0.220	11.950	3.97	(N/A)	(N/A)
Pond-1 (OUT)	Post-Development 1-Year	1	0.220	12.100	1.50	932.15	0.054
Pond-1 (IN)	Post-Development 10-Year	10	0.553	11.950	9.61	(N/A)	(N/A)
Pond-1 (OUT)	Post-Development 10-Year	10	0.552	12.150	2.12	932.94	0.182
Pond-1 (IN)	Post-Development 25-Year	25	0.717	11.950	12.27	(N/A)	(N/A)
Pond-1 (OUT)	Post-Development 25-Year	25	0.715	12.150	2.31	933.23	0.247
Pond-1 (IN)	Post-Development 100-Year	100	0.972	11.950	16.33	(N/A)	(N/A)
Pond-1 (OUT)	Post-Development 100-Year	100	0.970	12.200	2.55	933.65	0.357

Subsection: Time-Depth Curve  
 Label: Ithaca

Return Event: 100 years  
 Storm Event: 100-Year

---

Time-Depth Curve: 100-Year

---

Label	100-Year
Start Time	0.000 hours
Increment	0.100 hours
End Time	24.000 hours
Return Event	100 years

---

**CUMULATIVE RAINFALL (in)**  
**Output Time Increment = 0.100 hours**  
**Time on left represents time for first value in each row.**

Time (hours)	Depth (in)	Depth (in)	Depth (in)	Depth (in)	Depth (in)
0.000	0.0	0.0	0.0	0.0	0.0
0.500	0.0	0.0	0.0	0.1	0.1
1.000	0.1	0.1	0.1	0.1	0.1
1.500	0.1	0.1	0.1	0.1	0.1
2.000	0.1	0.1	0.1	0.2	0.2
2.500	0.2	0.2	0.2	0.2	0.2
3.000	0.2	0.2	0.2	0.2	0.2
3.500	0.2	0.3	0.3	0.3	0.3
4.000	0.3	0.3	0.3	0.3	0.3
4.500	0.3	0.3	0.4	0.4	0.4
5.000	0.4	0.4	0.4	0.4	0.4
5.500	0.4	0.4	0.4	0.5	0.5
6.000	0.5	0.5	0.5	0.5	0.5
6.500	0.5	0.5	0.6	0.6	0.6
7.000	0.6	0.6	0.6	0.6	0.6
7.500	0.7	0.7	0.7	0.7	0.7
8.000	0.7	0.7	0.8	0.8	0.8
8.500	0.8	0.8	0.8	0.8	0.9
9.000	0.9	0.9	0.9	0.9	1.0
9.500	1.0	1.0	1.0	1.0	1.1
10.000	1.1	1.1	1.1	1.2	1.2
10.500	1.2	1.3	1.3	1.3	1.4
11.000	1.4	1.5	1.5	1.6	1.6
11.500	1.7	1.8	2.1	2.6	3.4
12.000	4.0	4.1	4.2	4.3	4.4
12.500	4.4	4.5	4.5	4.6	4.6
13.000	4.6	4.7	4.7	4.8	4.8
13.500	4.8	4.8	4.9	4.9	4.9
14.000	4.9	5.0	5.0	5.0	5.0
14.500	5.0	5.1	5.1	5.1	5.1
15.000	5.1	5.2	5.2	5.2	5.2
15.500	5.2	5.2	5.3	5.3	5.3
16.000	5.3	5.3	5.3	5.3	5.4
16.500	5.4	5.4	5.4	5.4	5.4
17.000	5.4	5.4	5.5	5.5	5.5
17.500	5.5	5.5	5.5	5.5	5.5

Subsection: Time-Depth Curve  
 Label: Ithaca

Return Event: 100 years  
 Storm Event: 100-Year

**CUMULATIVE RAINFALL (in)**  
**Output Time Increment = 0.100 hours**  
**Time on left represents time for first value in each row.**

Time (hours)	Depth (in)	Depth (in)	Depth (in)	Depth (in)	Depth (in)
18.000	5.5	5.6	5.6	5.6	5.6
18.500	5.6	5.6	5.6	5.6	5.6
19.000	5.6	5.7	5.7	5.7	5.7
19.500	5.7	5.7	5.7	5.7	5.7
20.000	5.7	5.7	5.7	5.8	5.8
20.500	5.8	5.8	5.8	5.8	5.8
21.000	5.8	5.8	5.8	5.8	5.8
21.500	5.8	5.9	5.9	5.9	5.9
22.000	5.9	5.9	5.9	5.9	5.9
22.500	5.9	5.9	5.9	5.9	5.9
23.000	6.0	6.0	6.0	6.0	6.0
23.500	6.0	6.0	6.0	6.0	6.0
24.000	6.0	(N/A)	(N/A)	(N/A)	(N/A)

Subsection: Time-Depth Curve  
 Label: Ithaca

Return Event: 10 years  
 Storm Event: 10-Year

---

Time-Depth Curve: 10-Year

---

Label	10-Year
Start Time	0.000 hours
Increment	0.100 hours
End Time	24.000 hours
Return Event	10 years

---

**CUMULATIVE RAINFALL (in)**  
**Output Time Increment = 0.100 hours**  
**Time on left represents time for first value in each row.**

Time (hours)	Depth (in)	Depth (in)	Depth (in)	Depth (in)	Depth (in)
0.000	0.0	0.0	0.0	0.0	0.0
0.500	0.0	0.0	0.0	0.0	0.0
1.000	0.0	0.0	0.0	0.1	0.1
1.500	0.1	0.1	0.1	0.1	0.1
2.000	0.1	0.1	0.1	0.1	0.1
2.500	0.1	0.1	0.1	0.1	0.1
3.000	0.1	0.1	0.1	0.1	0.2
3.500	0.2	0.2	0.2	0.2	0.2
4.000	0.2	0.2	0.2	0.2	0.2
4.500	0.2	0.2	0.2	0.2	0.2
5.000	0.2	0.2	0.3	0.3	0.3
5.500	0.3	0.3	0.3	0.3	0.3
6.000	0.3	0.3	0.3	0.3	0.3
6.500	0.3	0.4	0.4	0.4	0.4
7.000	0.4	0.4	0.4	0.4	0.4
7.500	0.4	0.4	0.4	0.4	0.5
8.000	0.5	0.5	0.5	0.5	0.5
8.500	0.5	0.5	0.5	0.5	0.6
9.000	0.6	0.6	0.6	0.6	0.6
9.500	0.6	0.6	0.7	0.7	0.7
10.000	0.7	0.7	0.7	0.7	0.8
10.500	0.8	0.8	0.8	0.9	0.9
11.000	0.9	0.9	1.0	1.0	1.0
11.500	1.1	1.2	1.4	1.7	2.2
12.000	2.5	2.6	2.7	2.7	2.8
12.500	2.8	2.9	2.9	2.9	2.9
13.000	3.0	3.0	3.0	3.0	3.0
13.500	3.1	3.1	3.1	3.1	3.1
14.000	3.1	3.2	3.2	3.2	3.2
14.500	3.2	3.2	3.2	3.3	3.3
15.000	3.3	3.3	3.3	3.3	3.3
15.500	3.3	3.3	3.4	3.4	3.4
16.000	3.4	3.4	3.4	3.4	3.4
16.500	3.4	3.4	3.4	3.4	3.5
17.000	3.5	3.5	3.5	3.5	3.5
17.500	3.5	3.5	3.5	3.5	3.5

Subsection: Time-Depth Curve  
 Label: Ithaca

Return Event: 10 years  
 Storm Event: 10-Year

**CUMULATIVE RAINFALL (in)**  
**Output Time Increment = 0.100 hours**  
**Time on left represents time for first value in each row.**

Time (hours)	Depth (in)	Depth (in)	Depth (in)	Depth (in)	Depth (in)
18.000	3.5	3.5	3.6	3.6	3.6
18.500	3.6	3.6	3.6	3.6	3.6
19.000	3.6	3.6	3.6	3.6	3.6
19.500	3.6	3.6	3.6	3.6	3.7
20.000	3.7	3.7	3.7	3.7	3.7
20.500	3.7	3.7	3.7	3.7	3.7
21.000	3.7	3.7	3.7	3.7	3.7
21.500	3.7	3.7	3.7	3.7	3.7
22.000	3.8	3.8	3.8	3.8	3.8
22.500	3.8	3.8	3.8	3.8	3.8
23.000	3.8	3.8	3.8	3.8	3.8
23.500	3.8	3.8	3.8	3.8	3.8
24.000	3.8	(N/A)	(N/A)	(N/A)	(N/A)

Subsection: Time-Depth Curve  
 Label: Ithaca

Return Event: 1 years  
 Storm Event: 1-Year

---

Time-Depth Curve: 1-Year

---

Label	1-Year
Start Time	0.000 hours
Increment	0.100 hours
End Time	24.000 hours
Return Event	1 years

---

**CUMULATIVE RAINFALL (in)**  
**Output Time Increment = 0.100 hours**  
**Time on left represents time for first value in each row.**

Time (hours)	Depth (in)	Depth (in)	Depth (in)	Depth (in)	Depth (in)
0.000	0.0	0.0	0.0	0.0	0.0
0.500	0.0	0.0	0.0	0.0	0.0
1.000	0.0	0.0	0.0	0.0	0.0
1.500	0.0	0.0	0.0	0.0	0.0
2.000	0.0	0.0	0.0	0.1	0.1
2.500	0.1	0.1	0.1	0.1	0.1
3.000	0.1	0.1	0.1	0.1	0.1
3.500	0.1	0.1	0.1	0.1	0.1
4.000	0.1	0.1	0.1	0.1	0.1
4.500	0.1	0.1	0.1	0.1	0.1
5.000	0.1	0.1	0.1	0.1	0.1
5.500	0.1	0.1	0.2	0.2	0.2
6.000	0.2	0.2	0.2	0.2	0.2
6.500	0.2	0.2	0.2	0.2	0.2
7.000	0.2	0.2	0.2	0.2	0.2
7.500	0.2	0.2	0.2	0.2	0.2
8.000	0.2	0.2	0.3	0.3	0.3
8.500	0.3	0.3	0.3	0.3	0.3
9.000	0.3	0.3	0.3	0.3	0.3
9.500	0.3	0.3	0.3	0.3	0.4
10.000	0.4	0.4	0.4	0.4	0.4
10.500	0.4	0.4	0.4	0.4	0.5
11.000	0.5	0.5	0.5	0.5	0.5
11.500	0.6	0.6	0.7	0.9	1.1
12.000	1.3	1.4	1.4	1.4	1.5
12.500	1.5	1.5	1.5	1.5	1.5
13.000	1.6	1.6	1.6	1.6	1.6
13.500	1.6	1.6	1.6	1.6	1.6
14.000	1.6	1.7	1.7	1.7	1.7
14.500	1.7	1.7	1.7	1.7	1.7
15.000	1.7	1.7	1.7	1.7	1.7
15.500	1.7	1.7	1.8	1.8	1.8
16.000	1.8	1.8	1.8	1.8	1.8
16.500	1.8	1.8	1.8	1.8	1.8
17.000	1.8	1.8	1.8	1.8	1.8
17.500	1.8	1.8	1.8	1.8	1.8

Subsection: Time-Depth Curve  
 Label: Ithaca

Return Event: 1 years  
 Storm Event: 1-Year

**CUMULATIVE RAINFALL (in)**  
**Output Time Increment = 0.100 hours**  
**Time on left represents time for first value in each row.**

Time (hours)	Depth (in)	Depth (in)	Depth (in)	Depth (in)	Depth (in)
18.000	1.9	1.9	1.9	1.9	1.9
18.500	1.9	1.9	1.9	1.9	1.9
19.000	1.9	1.9	1.9	1.9	1.9
19.500	1.9	1.9	1.9	1.9	1.9
20.000	1.9	1.9	1.9	1.9	1.9
20.500	1.9	1.9	1.9	1.9	1.9
21.000	1.9	1.9	1.9	1.9	1.9
21.500	2.0	2.0	2.0	2.0	2.0
22.000	2.0	2.0	2.0	2.0	2.0
22.500	2.0	2.0	2.0	2.0	2.0
23.000	2.0	2.0	2.0	2.0	2.0
23.500	2.0	2.0	2.0	2.0	2.0
24.000	2.0	(N/A)	(N/A)	(N/A)	(N/A)

Subsection: Time-Depth Curve  
 Label: Ithaca

Return Event: 25 years  
 Storm Event: 25-Year

---

Time-Depth Curve: 25-Year

---

Label	25-Year
Start Time	0.000 hours
Increment	0.100 hours
End Time	24.000 hours
Return Event	25 years

---

**CUMULATIVE RAINFALL (in)**  
**Output Time Increment = 0.100 hours**  
**Time on left represents time for first value in each row.**

Time (hours)	Depth (in)	Depth (in)	Depth (in)	Depth (in)	Depth (in)
0.000	0.0	0.0	0.0	0.0	0.0
0.500	0.0	0.0	0.0	0.0	0.0
1.000	0.0	0.1	0.1	0.1	0.1
1.500	0.1	0.1	0.1	0.1	0.1
2.000	0.1	0.1	0.1	0.1	0.1
2.500	0.1	0.1	0.1	0.2	0.2
3.000	0.2	0.2	0.2	0.2	0.2
3.500	0.2	0.2	0.2	0.2	0.2
4.000	0.2	0.2	0.2	0.2	0.3
4.500	0.3	0.3	0.3	0.3	0.3
5.000	0.3	0.3	0.3	0.3	0.3
5.500	0.3	0.3	0.4	0.4	0.4
6.000	0.4	0.4	0.4	0.4	0.4
6.500	0.4	0.4	0.4	0.4	0.5
7.000	0.5	0.5	0.5	0.5	0.5
7.500	0.5	0.5	0.5	0.5	0.6
8.000	0.6	0.6	0.6	0.6	0.6
8.500	0.6	0.6	0.6	0.7	0.7
9.000	0.7	0.7	0.7	0.7	0.8
9.500	0.8	0.8	0.8	0.8	0.8
10.000	0.9	0.9	0.9	0.9	0.9
10.500	1.0	1.0	1.0	1.0	1.1
11.000	1.1	1.1	1.2	1.2	1.3
11.500	1.3	1.4	1.7	2.0	2.7
12.000	3.1	3.2	3.3	3.4	3.4
12.500	3.5	3.5	3.5	3.6	3.6
13.000	3.6	3.7	3.7	3.7	3.7
13.500	3.8	3.8	3.8	3.8	3.8
14.000	3.9	3.9	3.9	3.9	3.9
14.500	3.9	4.0	4.0	4.0	4.0
15.000	4.0	4.0	4.0	4.1	4.1
15.500	4.1	4.1	4.1	4.1	4.1
16.000	4.1	4.1	4.2	4.2	4.2
16.500	4.2	4.2	4.2	4.2	4.2
17.000	4.2	4.2	4.3	4.3	4.3
17.500	4.3	4.3	4.3	4.3	4.3



Subsection: Time-Depth Curve  
 Label: Ithaca

Return Event: 25 years  
 Storm Event: 25-Year

**CUMULATIVE RAINFALL (in)**  
**Output Time Increment = 0.100 hours**  
**Time on left represents time for first value in each row.**

Time (hours)	Depth (in)	Depth (in)	Depth (in)	Depth (in)	Depth (in)
18.000	4.3	4.3	4.3	4.4	4.4
18.500	4.4	4.4	4.4	4.4	4.4
19.000	4.4	4.4	4.4	4.4	4.4
19.500	4.4	4.4	4.5	4.5	4.5
20.000	4.5	4.5	4.5	4.5	4.5
20.500	4.5	4.5	4.5	4.5	4.5
21.000	4.5	4.5	4.5	4.6	4.6
21.500	4.6	4.6	4.6	4.6	4.6
22.000	4.6	4.6	4.6	4.6	4.6
22.500	4.6	4.6	4.6	4.6	4.6
23.000	4.6	4.7	4.7	4.7	4.7
23.500	4.7	4.7	4.7	4.7	4.7
24.000	4.7	(N/A)	(N/A)	(N/A)	(N/A)

Subsection: Unit Hydrograph Equations

**Unit Hydrograph Method (Computational Notes)**

**Definition of Terms**

At	Total area (acres): $A_t = A_i + A_p$
Ai	Impervious area (acres)
Ap	Pervious area (acres)
CNi	Runoff curve number for impervious area
CNp	Runoff curve number for pervious area
fLoss	f loss constant infiltration (depth/time)
gKs	Saturated Hydraulic Conductivity (depth/time)
Md	Volumetric Moisture Deficit
Psi	Capillary Suction (length)
hK	Horton Infiltration Decay Rate ( $\text{time}^{-1}$ )
fo	Initial Infiltration Rate (depth/time)
fc	Ultimate(capacity)Infiltration Rate (depth/time)
Ia	Initial Abstraction (length)
dt	Computational increment (duration of unit excess rainfall) Default dt is smallest value of $0.1333T_c$ , $r_{tm}$ , and $t_h$ (Smallest dt is then adjusted to match up with $T_p$ )
UDdt	User specified override computational main time increment (only used if UDdt is $\Rightarrow .1333T_c$ )
D(t)	Point on distribution curve (fraction of P) for time step t
K	$2 / (1 + (T_r/T_p))$ : default K = 0.75: (for $T_r/T_p = 1.67$ )
Ks	Hydrograph shape factor = Unit Conversions * K: = $((1\text{hr}/3600\text{sec}) * (1\text{ft}/12\text{in}) * ((5280\text{ft})^2/\text{sq.mi})) * K$ Default $K_s = 645.333 * 0.75 = 484$
Lag	Lag time from center of excess runoff (dt) to $T_p$ : $\text{Lag} = 0.6T_c$
P	Total precipitation depth, inches
Pa(t)	Accumulated rainfall at time step t
Pi(t)	Incremental rainfall at time step t
qp	Peak discharge (cfs) for 1in. runoff, for 1hr, for 1 sq.mi. = $(K_s * A * Q) / T_p$ (where $Q = 1\text{in. runoff}$ , $A = \text{sq.mi.}$ )
Qu(t)	Unit hydrograph ordinate (cfs) at time step t
Q(t)	Final hydrograph ordinate (cfs) at time step t
Rai(t)	Accumulated runoff (inches) at time step t for impervious area
Rap(t)	Accumulated runoff (inches) at time step t for pervious area
Rii(t)	Incremental runoff (inches) at time step t for impervious area
Rip(t)	Incremental runoff (inches) at time step t for pervious area
R(t)	Incremental weighted total runoff (inches)
Rtm	Time increment for rainfall table
Si	S for impervious area: $S_i = (1000/CN_i) - 10$
Sp	S for pervious area: $S_p = (1000/CN_p) - 10$
t	Time step (row) number
Tc	Time of concentration
Tb	Time (hrs) of entire unit hydrograph: $T_b = T_p + T_r$
Tp	Time (hrs) to peak of a unit hydrograph: $T_p = (dt/2) + \text{Lag}$
Tr	Time (hrs) of receding limb of unit hydrograph: $T_r = \text{ratio of } T_p$

Subsection: Unit Hydrograph Equations

## Unit Hydrograph Method

### Computational Notes

#### Precipitation

Column (1)	Time for time step t
Column (2)	$D(t)$ = Point on distribution curve for time step t
Column (3)	$P_i(t) = P_a(t) - P_a(t-1)$ : Col.(4) - Preceding Col.(4)
Column (4)	$P_a(t) = D(t) \times P$ : Col.(2) x P

#### Pervious Area Runoff (using SCS Runoff CN Method)

Column (5)	$R_{ap}(t)$ = Accumulated pervious runoff for time step t If $(P_a(t))$ is $\leq 0.2S_p$ then use: $R_{ap}(t) = 0.0$ If $(P_a(t))$ is $> 0.2S_p$ then use:  $R_{ap}(t) = (Col.(4) - 0.2S_p) \times 2 / (Col.(4) + 0.8S_p)$
Column (6)	$R_{ip}(t)$ = Incremental pervious runoff for time step t $R_{ip}(t) = R_{ap}(t) - R_{ap}(t-1)$ $R_{ip}(t) = Col.(5)$ for current row - $Col.(5)$ for preceding row.

#### Impervious Area Runoff

Column (7 & 8)...	Did not specify to use impervious areas.
-------------------	--

#### Incremental Weighted Runoff

Column (9)	$R(t) = (A_p/A_t) \times R_{ip}(t) + (A_i/A_t) \times R_{ii}(t)$ $R(t) = (A_p/A_t) \times Col.(6) + (A_i/A_t) \times Col.(8)$
------------	--

#### SCS Unit Hydrograph Method

Column (10)	$Q(t)$ is computed with the SCS unit hydrograph method using $R(t)$ and $Q_u(t)$ .
-------------	--

Subsection: Unit Hydrograph Summary  
 Label: Post-Development DA-1

Return Event: 1 years  
 Storm Event: 1-Year

Storm Event	1-Year
Return Event	1 years
Duration	24.000 hours
Depth	2.0 in
Time of Concentration (Composite)	0.100 hours
Area (User Defined)	2.400 acres
<hr/>	
Computational Time Increment	0.013 hours
Time to Peak (Computed)	11.933 hours
Flow (Peak, Computed)	4.03 ft <sup>3</sup> /s
Output Increment	0.050 hours
Time to Flow (Peak Interpolated Output)	11.950 hours
Flow (Peak Interpolated Output)	3.97 ft <sup>3</sup> /s
<hr/>	
Drainage Area	
SCS CN (Composite)	90.000
Area (User Defined)	2.400 acres
Maximum Retention (Pervious)	1.1 in
Maximum Retention (Pervious, 20 percent)	0.2 in
<hr/>	
Cumulative Runoff	
Cumulative Runoff Depth (Pervious)	1.1 in
Runoff Volume (Pervious)	0.221 ac-ft
<hr/>	
Hydrograph Volume (Area under Hydrograph curve)	
Volume	0.220 ac-ft
<hr/>	
SCS Unit Hydrograph Parameters	
Time of Concentration (Composite)	0.100 hours
Computational Time Increment	0.013 hours
Unit Hydrograph Shape Factor	483.432
K Factor	0.749
Receding/Rising, Tr/Tp	1.670
Unit peak, qp	27.19 ft <sup>3</sup> /s
Unit peak time, Tp	0.067 hours

Subsection: Unit Hydrograph Summary  
Label: Post-Development DA-1

Return Event: 1 years  
Storm Event: 1-Year

---

SCS Unit Hydrograph Parameters	
Unit receding limb, Tr	0.267 hours
Total unit time, Tb	0.333 hours

---

Subsection: Unit Hydrograph Summary  
 Label: Post-Development DA-1

Return Event: 10 years  
 Storm Event: 10-Year

Storm Event	10-Year
Return Event	10 years
Duration	24.000 hours
Depth	3.8 in
Time of Concentration (Composite)	0.100 hours
Area (User Defined)	2.400 acres

Computational Time Increment	0.013 hours
Time to Peak (Computed)	11.933 hours
Flow (Peak, Computed)	9.87 ft <sup>3</sup> /s
Output Increment	0.050 hours
Time to Flow (Peak Interpolated Output)	11.950 hours
Flow (Peak Interpolated Output)	9.61 ft <sup>3</sup> /s

Drainage Area	
SCS CN (Composite)	90.000
Area (User Defined)	2.400 acres
Maximum Retention (Pervious)	1.1 in
Maximum Retention (Pervious, 20 percent)	0.2 in

Cumulative Runoff	
Cumulative Runoff Depth (Pervious)	2.8 in
Runoff Volume (Pervious)	0.554 ac-ft

Hydrograph Volume (Area under Hydrograph curve)	
Volume	0.553 ac-ft

SCS Unit Hydrograph Parameters	
Time of Concentration (Composite)	0.100 hours
Computational Time Increment	0.013 hours
Unit Hydrograph Shape Factor	483.432
K Factor	0.749
Receding/Rising, Tr/Tp	1.670
Unit peak, qp	27.19 ft <sup>3</sup> /s
Unit peak time, Tp	0.067 hours

Subsection: Unit Hydrograph Summary  
Label: Post-Development DA-1

Return Event: 10 years  
Storm Event: 10-Year

---

SCS Unit Hydrograph Parameters	
Unit receding limb, Tr	0.267 hours
Total unit time, Tb	0.333 hours

---

Subsection: Unit Hydrograph Summary  
 Label: Post-Development DA-1

Return Event: 25 years  
 Storm Event: 25-Year

Storm Event	25-Year
Return Event	25 years
Duration	24.000 hours
Depth	4.7 in
Time of Concentration (Composite)	0.100 hours
Area (User Defined)	2.400 acres
<hr/>	
Computational Time Increment	0.013 hours
Time to Peak (Computed)	11.933 hours
Flow (Peak, Computed)	12.62 ft <sup>3</sup> /s
Output Increment	0.050 hours
Time to Flow (Peak Interpolated Output)	11.950 hours
Flow (Peak Interpolated Output)	12.27 ft <sup>3</sup> /s
<hr/>	
Drainage Area	
SCS CN (Composite)	90.000
Area (User Defined)	2.400 acres
Maximum Retention (Pervious)	1.1 in
Maximum Retention (Pervious, 20 percent)	0.2 in
<hr/>	
Cumulative Runoff	
Cumulative Runoff Depth (Pervious)	3.6 in
Runoff Volume (Pervious)	0.718 ac-ft
<hr/>	
Hydrograph Volume (Area under Hydrograph curve)	
Volume	0.717 ac-ft
<hr/>	
SCS Unit Hydrograph Parameters	
Time of Concentration (Composite)	0.100 hours
Computational Time Increment	0.013 hours
Unit Hydrograph Shape Factor	483.432
K Factor	0.749
Receding/Rising, Tr/Tp	1.670
Unit peak, qp	27.19 ft <sup>3</sup> /s
Unit peak time, Tp	0.067 hours



Subsection: Unit Hydrograph Summary  
Label: Post-Development DA-1

Return Event: 25 years  
Storm Event: 25-Year

---

SCS Unit Hydrograph Parameters	
Unit receding limb, Tr	0.267 hours
Total unit time, Tb	0.333 hours

---

Subsection: Unit Hydrograph Summary  
 Label: Post-Development DA-1

Return Event: 100 years  
 Storm Event: 100-Year

Storm Event	100-Year
Return Event	100 years
Duration	24.000 hours
Depth	6.0 in
Time of Concentration (Composite)	0.100 hours
Area (User Defined)	2.400 acres

Computational Time Increment	0.013 hours
Time to Peak (Computed)	11.933 hours
Flow (Peak, Computed)	16.83 ft <sup>3</sup> /s
Output Increment	0.050 hours
Time to Flow (Peak Interpolated Output)	11.950 hours
Flow (Peak Interpolated Output)	16.33 ft <sup>3</sup> /s

Drainage Area	
SCS CN (Composite)	90.000
Area (User Defined)	2.400 acres
Maximum Retention (Pervious)	1.1 in
Maximum Retention (Pervious, 20 percent)	0.2 in

Cumulative Runoff	
Cumulative Runoff Depth (Pervious)	4.9 in
Runoff Volume (Pervious)	0.973 ac-ft

Hydrograph Volume (Area under Hydrograph curve)	
Volume	0.972 ac-ft

SCS Unit Hydrograph Parameters	
Time of Concentration (Composite)	0.100 hours
Computational Time Increment	0.013 hours
Unit Hydrograph Shape Factor	483.432
K Factor	0.749
Receding/Rising, Tr/Tp	1.670
Unit peak, qp	27.19 ft <sup>3</sup> /s
Unit peak time, Tp	0.067 hours

Subsection: Unit Hydrograph Summary  
Label: Post-Development DA-1

Return Event: 100 years  
Storm Event: 100-Year

---

SCS Unit Hydrograph Parameters	
Unit receding limb, Tr	0.267 hours
Total unit time, Tb	0.333 hours

---

Subsection: Unit Hydrograph Summary  
 Label: Post-Development DA-1 Bypass

Return Event: 1 years  
 Storm Event: 1-Year

Storm Event	1-Year
Return Event	1 years
Duration	24.000 hours
Depth	2.0 in
Time of Concentration (Composite)	0.250 hours
Area (User Defined)	5.460 acres

Computational Time Increment	0.033 hours
Time to Peak (Computed)	12.067 hours
Flow (Peak, Computed)	5.26 ft <sup>3</sup> /s
Output Increment	0.050 hours
Time to Flow (Peak Interpolated Output)	12.050 hours
Flow (Peak Interpolated Output)	5.25 ft <sup>3</sup> /s

Drainage Area	
SCS CN (Composite)	85.000
Area (User Defined)	5.460 acres
Maximum Retention (Pervious)	1.8 in
Maximum Retention (Pervious, 20 percent)	0.4 in

Cumulative Runoff	
Cumulative Runoff Depth (Pervious)	0.8 in
Runoff Volume (Pervious)	0.365 ac-ft

Hydrograph Volume (Area under Hydrograph curve)	
Volume	0.364 ac-ft

SCS Unit Hydrograph Parameters	
Time of Concentration (Composite)	0.250 hours
Computational Time Increment	0.033 hours
Unit Hydrograph Shape Factor	483.432
K Factor	0.749
Receding/Rising, Tr/Tp	1.670
Unit peak, qp	24.75 ft <sup>3</sup> /s
Unit peak time, Tp	0.167 hours

Subsection: Unit Hydrograph Summary  
Label: Post-Development DA-1 Bypass

Return Event: 1 years  
Storm Event: 1-Year

---

SCS Unit Hydrograph Parameters	
Unit receding limb, Tr	0.667 hours
Total unit time, Tb	0.833 hours

---

Subsection: Unit Hydrograph Summary  
 Label: Post-Development DA-1 Bypass

Return Event: 10 years  
 Storm Event: 10-Year

Storm Event	10-Year
Return Event	10 years
Duration	24.000 hours
Depth	3.8 in
Time of Concentration (Composite)	0.250 hours
Area (User Defined)	5.460 acres
<hr/>	
Computational Time Increment	0.033 hours
Time to Peak (Computed)	12.033 hours
Flow (Peak, Computed)	15.36 ft <sup>3</sup> /s
Output Increment	0.050 hours
Time to Flow (Peak Interpolated Output)	12.050 hours
Flow (Peak Interpolated Output)	15.23 ft <sup>3</sup> /s
<hr/>	
Drainage Area	
SCS CN (Composite)	85.000
Area (User Defined)	5.460 acres
Maximum Retention (Pervious)	1.8 in
Maximum Retention (Pervious, 20 percent)	0.4 in
<hr/>	
Cumulative Runoff	
Cumulative Runoff Depth (Pervious)	2.3 in
Runoff Volume (Pervious)	1.053 ac-ft
<hr/>	
Hydrograph Volume (Area under Hydrograph curve)	
Volume	1.050 ac-ft
<hr/>	
SCS Unit Hydrograph Parameters	
Time of Concentration (Composite)	0.250 hours
Computational Time Increment	0.033 hours
Unit Hydrograph Shape Factor	483.432
K Factor	0.749
Receding/Rising, Tr/Tp	1.670
Unit peak, qp	24.75 ft <sup>3</sup> /s
Unit peak time, Tp	0.167 hours

Subsection: Unit Hydrograph Summary  
Label: Post-Development DA-1 Bypass

Return Event: 10 years  
Storm Event: 10-Year

---

SCS Unit Hydrograph Parameters

---

Unit receding limb, Tr	0.667 hours
Total unit time, Tb	0.833 hours

---

Subsection: Unit Hydrograph Summary  
 Label: Post-Development DA-1 Bypass

Return Event: 25 years  
 Storm Event: 25-Year

Storm Event	25-Year
Return Event	25 years
Duration	24.000 hours
Depth	4.7 in
Time of Concentration (Composite)	0.250 hours
Area (User Defined)	5.460 acres
<hr/>	
Computational Time Increment	0.033 hours
Time to Peak (Computed)	12.033 hours
Flow (Peak, Computed)	20.37 ft <sup>3</sup> /s
Output Increment	0.050 hours
Time to Flow (Peak Interpolated Output)	12.050 hours
Flow (Peak Interpolated Output)	20.17 ft <sup>3</sup> /s
<hr/>	
Drainage Area	
SCS CN (Composite)	85.000
Area (User Defined)	5.460 acres
Maximum Retention (Pervious)	1.8 in
Maximum Retention (Pervious, 20 percent)	0.4 in
<hr/>	
Cumulative Runoff	
Cumulative Runoff Depth (Pervious)	3.1 in
Runoff Volume (Pervious)	1.407 ac-ft
<hr/>	
Hydrograph Volume (Area under Hydrograph curve)	
Volume	1.403 ac-ft
<hr/>	
SCS Unit Hydrograph Parameters	
Time of Concentration (Composite)	0.250 hours
Computational Time Increment	0.033 hours
Unit Hydrograph Shape Factor	483.432
K Factor	0.749
Receding/Rising, Tr/Tp	1.670
Unit peak, qp	24.75 ft <sup>3</sup> /s
Unit peak time, Tp	0.167 hours



Subsection: Unit Hydrograph Summary  
Label: Post-Development DA-1 Bypass

Return Event: 25 years  
Storm Event: 25-Year

---

SCS Unit Hydrograph Parameters

---

Unit receding limb, Tr	0.667 hours
Total unit time, Tb	0.833 hours

---

Subsection: Unit Hydrograph Summary  
 Label: Post-Development DA-1 Bypass

Return Event: 100 years  
 Storm Event: 100-Year

Storm Event	100-Year
Return Event	100 years
Duration	24.000 hours
Depth	6.0 in
Time of Concentration (Composite)	0.250 hours
Area (User Defined)	5.460 acres

Computational Time Increment	0.033 hours
Time to Peak (Computed)	12.033 hours
Flow (Peak, Computed)	28.13 ft <sup>3</sup> /s
Output Increment	0.050 hours
Time to Flow (Peak Interpolated Output)	12.050 hours
Flow (Peak Interpolated Output)	27.79 ft <sup>3</sup> /s

Drainage Area	
SCS CN (Composite)	85.000
Area (User Defined)	5.460 acres
Maximum Retention (Pervious)	1.8 in
Maximum Retention (Pervious, 20 percent)	0.4 in

Cumulative Runoff	
Cumulative Runoff Depth (Pervious)	4.3 in
Runoff Volume (Pervious)	1.966 ac-ft

Hydrograph Volume (Area under Hydrograph curve)	
Volume	1.961 ac-ft

SCS Unit Hydrograph Parameters	
Time of Concentration (Composite)	0.250 hours
Computational Time Increment	0.033 hours
Unit Hydrograph Shape Factor	483.432
K Factor	0.749
Receding/Rising, Tr/Tp	1.670
Unit peak, qp	24.75 ft <sup>3</sup> /s
Unit peak time, Tp	0.167 hours

Subsection: Unit Hydrograph Summary  
Label: Post-Development DA-1 Bypass

Return Event: 100 years  
Storm Event: 100-Year

---

SCS Unit Hydrograph Parameters	
Unit receding limb, Tr	0.667 hours
Total unit time, Tb	0.833 hours

---

Subsection: Unit Hydrograph Summary  
 Label: Post-Development DA-1 Offsite

Return Event: 1 years  
 Storm Event: 1-Year

Storm Event	1-Year
Return Event	1 years
Duration	24.000 hours
Depth	2.0 in
Time of Concentration (Composite)	0.500 hours
Area (User Defined)	5.050 acres

Computational Time Increment	0.067 hours
Time to Peak (Computed)	12.200 hours
Flow (Peak, Computed)	3.37 ft <sup>3</sup> /s
Output Increment	0.050 hours
Time to Flow (Peak Interpolated Output)	12.200 hours
Flow (Peak Interpolated Output)	3.37 ft <sup>3</sup> /s

Drainage Area	
SCS CN (Composite)	85.000
Area (User Defined)	5.050 acres
Maximum Retention (Pervious)	1.8 in
Maximum Retention (Pervious, 20 percent)	0.4 in

Cumulative Runoff	
Cumulative Runoff Depth (Pervious)	0.8 in
Runoff Volume (Pervious)	0.338 ac-ft

Hydrograph Volume (Area under Hydrograph curve)	
Volume	0.335 ac-ft

SCS Unit Hydrograph Parameters	
Time of Concentration (Composite)	0.500 hours
Computational Time Increment	0.067 hours
Unit Hydrograph Shape Factor	483.432
K Factor	0.749
Receding/Rising, Tr/Tp	1.670
Unit peak, qp	11.44 ft <sup>3</sup> /s
Unit peak time, Tp	0.333 hours

Subsection: Unit Hydrograph Summary  
Label: Post-Development DA-1 Offsite

Return Event: 1 years  
Storm Event: 1-Year

---

SCS Unit Hydrograph Parameters

---

Unit receding limb, Tr	1.333 hours
Total unit time, Tb	1.667 hours

---

Subsection: Unit Hydrograph Summary  
 Label: Post-Development DA-1 Offsite

Return Event: 10 years  
 Storm Event: 10-Year

Storm Event	10-Year
Return Event	10 years
Duration	24.000 hours
Depth	3.8 in
Time of Concentration (Composite)	0.500 hours
Area (User Defined)	5.050 acres

Computational Time Increment	0.067 hours
Time to Peak (Computed)	12.200 hours
Flow (Peak, Computed)	9.98 ft <sup>3</sup> /s
Output Increment	0.050 hours
Time to Flow (Peak Interpolated Output)	12.200 hours
Flow (Peak Interpolated Output)	9.98 ft <sup>3</sup> /s

Drainage Area	
SCS CN (Composite)	85.000
Area (User Defined)	5.050 acres
Maximum Retention (Pervious)	1.8 in
Maximum Retention (Pervious, 20 percent)	0.4 in

Cumulative Runoff	
Cumulative Runoff Depth (Pervious)	2.3 in
Runoff Volume (Pervious)	0.974 ac-ft

Hydrograph Volume (Area under Hydrograph curve)	
Volume	0.968 ac-ft

SCS Unit Hydrograph Parameters	
Time of Concentration (Composite)	0.500 hours
Computational Time Increment	0.067 hours
Unit Hydrograph Shape Factor	483.432
K Factor	0.749
Receding/Rising, Tr/Tp	1.670
Unit peak, qp	11.44 ft <sup>3</sup> /s
Unit peak time, Tp	0.333 hours

Subsection: Unit Hydrograph Summary  
Label: Post-Development DA-1 Offsite

Return Event: 10 years  
Storm Event: 10-Year

---

SCS Unit Hydrograph Parameters	
Unit receding limb, Tr	1.333 hours
Total unit time, Tb	1.667 hours

---

Subsection: Unit Hydrograph Summary  
 Label: Post-Development DA-1 Offsite

Return Event: 25 years  
 Storm Event: 25-Year

Storm Event	25-Year
Return Event	25 years
Duration	24.000 hours
Depth	4.7 in
Time of Concentration (Composite)	0.500 hours
Area (User Defined)	5.050 acres

Computational Time Increment	0.067 hours
Time to Peak (Computed)	12.200 hours
Flow (Peak, Computed)	13.26 ft <sup>3</sup> /s
Output Increment	0.050 hours
Time to Flow (Peak Interpolated Output)	12.200 hours
Flow (Peak Interpolated Output)	13.26 ft <sup>3</sup> /s

Drainage Area	
SCS CN (Composite)	85.000
Area (User Defined)	5.050 acres
Maximum Retention (Pervious)	1.8 in
Maximum Retention (Pervious, 20 percent)	0.4 in

Cumulative Runoff	
Cumulative Runoff Depth (Pervious)	3.1 in
Runoff Volume (Pervious)	1.301 ac-ft

Hydrograph Volume (Area under Hydrograph curve)	
Volume	1.293 ac-ft

SCS Unit Hydrograph Parameters	
Time of Concentration (Composite)	0.500 hours
Computational Time Increment	0.067 hours
Unit Hydrograph Shape Factor	483.432
K Factor	0.749
Receding/Rising, Tr/Tp	1.670
Unit peak, qp	11.44 ft <sup>3</sup> /s
Unit peak time, Tp	0.333 hours



Subsection: Unit Hydrograph Summary  
Label: Post-Development DA-1 Offsite

Return Event: 25 years  
Storm Event: 25-Year

---

SCS Unit Hydrograph Parameters	
Unit receding limb, Tr	1.333 hours
Total unit time, Tb	1.667 hours

---

Subsection: Unit Hydrograph Summary  
 Label: Post-Development DA-1 Offsite

Return Event: 100 years  
 Storm Event: 100-Year

Storm Event	100-Year
Return Event	100 years
Duration	24.000 hours
Depth	6.0 in
Time of Concentration (Composite)	0.500 hours
Area (User Defined)	5.050 acres

Computational Time Increment	0.067 hours
Time to Peak (Computed)	12.200 hours
Flow (Peak, Computed)	18.35 ft <sup>3</sup> /s
Output Increment	0.050 hours
Time to Flow (Peak Interpolated Output)	12.200 hours
Flow (Peak Interpolated Output)	18.35 ft <sup>3</sup> /s

Drainage Area	
SCS CN (Composite)	85.000
Area (User Defined)	5.050 acres
Maximum Retention (Pervious)	1.8 in
Maximum Retention (Pervious, 20 percent)	0.4 in

Cumulative Runoff	
Cumulative Runoff Depth (Pervious)	4.3 in
Runoff Volume (Pervious)	1.819 ac-ft

Hydrograph Volume (Area under Hydrograph curve)	
Volume	1.808 ac-ft

SCS Unit Hydrograph Parameters	
Time of Concentration (Composite)	0.500 hours
Computational Time Increment	0.067 hours
Unit Hydrograph Shape Factor	483.432
K Factor	0.749
Receding/Rising, Tr/Tp	1.670
Unit peak, qp	11.44 ft <sup>3</sup> /s
Unit peak time, Tp	0.333 hours

Subsection: Unit Hydrograph Summary  
Label: Post-Development DA-1 Offsite

Return Event: 100 years  
Storm Event: 100-Year

---

SCS Unit Hydrograph Parameters	
Unit receding limb, Tr	1.333 hours
Total unit time, Tb	1.667 hours

---

Subsection: Unit Hydrograph Summary  
 Label: Post-Development DA-2

Return Event: 1 years  
 Storm Event: 1-Year

Storm Event	1-Year
Return Event	1 years
Duration	24.000 hours
Depth	2.0 in
Time of Concentration (Composite)	0.100 hours
Area (User Defined)	7.860 acres

Computational Time Increment	0.013 hours
Time to Peak (Computed)	11.933 hours
Flow (Peak, Computed)	13.21 ft <sup>3</sup> /s
Output Increment	0.050 hours
Time to Flow (Peak Interpolated Output)	11.950 hours
Flow (Peak Interpolated Output)	12.99 ft <sup>3</sup> /s

Drainage Area	
SCS CN (Composite)	90.000
Area (User Defined)	7.860 acres
Maximum Retention (Pervious)	1.1 in
Maximum Retention (Pervious, 20 percent)	0.2 in

Cumulative Runoff	
Cumulative Runoff Depth (Pervious)	1.1 in
Runoff Volume (Pervious)	0.722 ac-ft

Hydrograph Volume (Area under Hydrograph curve)	
Volume	0.721 ac-ft

SCS Unit Hydrograph Parameters	
Time of Concentration (Composite)	0.100 hours
Computational Time Increment	0.013 hours
Unit Hydrograph Shape Factor	483.432
K Factor	0.749
Receding/Rising, Tr/Tp	1.670
Unit peak, qp	89.06 ft <sup>3</sup> /s
Unit peak time, Tp	0.067 hours

Subsection: Unit Hydrograph Summary  
Label: Post-Development DA-2

Return Event: 1 years  
Storm Event: 1-Year

---

SCS Unit Hydrograph Parameters	
Unit receding limb, Tr	0.267 hours
Total unit time, Tb	0.333 hours

---

Subsection: Unit Hydrograph Summary  
 Label: Post-Development DA-2

Return Event: 10 years  
 Storm Event: 10-Year

Storm Event	10-Year
Return Event	10 years
Duration	24.000 hours
Depth	3.8 in
Time of Concentration (Composite)	0.100 hours
Area (User Defined)	7.860 acres
<hr/>	
Computational Time Increment	0.013 hours
Time to Peak (Computed)	11.933 hours
Flow (Peak, Computed)	32.32 ft <sup>3</sup> /s
Output Increment	0.050 hours
Time to Flow (Peak Interpolated Output)	11.950 hours
Flow (Peak Interpolated Output)	31.48 ft <sup>3</sup> /s
<hr/>	
Drainage Area	
SCS CN (Composite)	90.000
Area (User Defined)	7.860 acres
Maximum Retention (Pervious)	1.1 in
Maximum Retention (Pervious, 20 percent)	0.2 in
<hr/>	
Cumulative Runoff	
Cumulative Runoff Depth (Pervious)	2.8 in
Runoff Volume (Pervious)	1.813 ac-ft
<hr/>	
Hydrograph Volume (Area under Hydrograph curve)	
Volume	1.811 ac-ft
<hr/>	
SCS Unit Hydrograph Parameters	
Time of Concentration (Composite)	0.100 hours
Computational Time Increment	0.013 hours
Unit Hydrograph Shape Factor	483.432
K Factor	0.749
Receding/Rising, Tr/Tp	1.670
Unit peak, qp	89.06 ft <sup>3</sup> /s
Unit peak time, Tp	0.067 hours

Subsection: Unit Hydrograph Summary  
Label: Post-Development DA-2

Return Event: 10 years  
Storm Event: 10-Year

---

SCS Unit Hydrograph Parameters	
Unit receding limb, Tr	0.267 hours
Total unit time, Tb	0.333 hours

---

Subsection: Unit Hydrograph Summary  
 Label: Post-Development DA-2

Return Event: 25 years  
 Storm Event: 25-Year

Storm Event	25-Year
Return Event	25 years
Duration	24.000 hours
Depth	4.7 in
Time of Concentration (Composite)	0.100 hours
Area (User Defined)	7.860 acres
<hr/>	
Computational Time Increment	0.013 hours
Time to Peak (Computed)	11.933 hours
Flow (Peak, Computed)	41.34 ft <sup>3</sup> /s
Output Increment	0.050 hours
Time to Flow (Peak Interpolated Output)	11.950 hours
Flow (Peak Interpolated Output)	40.20 ft <sup>3</sup> /s
<hr/>	
Drainage Area	
SCS CN (Composite)	90.000
Area (User Defined)	7.860 acres
Maximum Retention (Pervious)	1.1 in
Maximum Retention (Pervious, 20 percent)	0.2 in
<hr/>	
Cumulative Runoff	
Cumulative Runoff Depth (Pervious)	3.6 in
Runoff Volume (Pervious)	2.350 ac-ft
<hr/>	
Hydrograph Volume (Area under Hydrograph curve)	
Volume	2.347 ac-ft
<hr/>	
SCS Unit Hydrograph Parameters	
Time of Concentration (Composite)	0.100 hours
Computational Time Increment	0.013 hours
Unit Hydrograph Shape Factor	483.432
K Factor	0.749
Receding/Rising, Tr/Tp	1.670
Unit peak, qp	89.06 ft <sup>3</sup> /s
Unit peak time, Tp	0.067 hours



Subsection: Unit Hydrograph Summary  
Label: Post-Development DA-2

Return Event: 25 years  
Storm Event: 25-Year

---

SCS Unit Hydrograph Parameters	
Unit receding limb, Tr	0.267 hours
Total unit time, Tb	0.333 hours

---

Subsection: Unit Hydrograph Summary  
 Label: Post-Development DA-2

Return Event: 100 years  
 Storm Event: 100-Year

Storm Event	100-Year
Return Event	100 years
Duration	24.000 hours
Depth	6.0 in
Time of Concentration (Composite)	0.100 hours
Area (User Defined)	7.860 acres

Computational Time Increment	0.013 hours
Time to Peak (Computed)	11.933 hours
Flow (Peak, Computed)	55.10 ft <sup>3</sup> /s
Output Increment	0.050 hours
Time to Flow (Peak Interpolated Output)	11.950 hours
Flow (Peak Interpolated Output)	53.49 ft <sup>3</sup> /s

Drainage Area	
SCS CN (Composite)	90.000
Area (User Defined)	7.860 acres
Maximum Retention (Pervious)	1.1 in
Maximum Retention (Pervious, 20 percent)	0.2 in

Cumulative Runoff	
Cumulative Runoff Depth (Pervious)	4.9 in
Runoff Volume (Pervious)	3.187 ac-ft

Hydrograph Volume (Area under Hydrograph curve)	
Volume	3.183 ac-ft

SCS Unit Hydrograph Parameters	
Time of Concentration (Composite)	0.100 hours
Computational Time Increment	0.013 hours
Unit Hydrograph Shape Factor	483.432
K Factor	0.749
Receding/Rising, Tr/Tp	1.670
Unit peak, qp	89.06 ft <sup>3</sup> /s
Unit peak time, Tp	0.067 hours

Subsection: Unit Hydrograph Summary  
Label: Post-Development DA-2

Return Event: 100 years  
Storm Event: 100-Year

---

SCS Unit Hydrograph Parameters	
Unit receding limb, Tr	0.267 hours
Total unit time, Tb	0.333 hours

---

Subsection: Unit Hydrograph Summary  
 Label: Post-Development DA-2 Bypass

Return Event: 1 years  
 Storm Event: 1-Year

Storm Event	1-Year
Return Event	1 years
Duration	24.000 hours
Depth	2.0 in
Time of Concentration (Composite)	0.167 hours
Area (User Defined)	0.160 acres

Computational Time Increment	0.022 hours
Time to Peak (Computed)	12.022 hours
Flow (Peak, Computed)	0.10 ft <sup>3</sup> /s
Output Increment	0.050 hours
Time to Flow (Peak Interpolated Output)	12.000 hours
Flow (Peak Interpolated Output)	0.10 ft <sup>3</sup> /s

Drainage Area	
SCS CN (Composite)	78.000
Area (User Defined)	0.160 acres
Maximum Retention (Pervious)	2.8 in
Maximum Retention (Pervious, 20 percent)	0.6 in

Cumulative Runoff	
Cumulative Runoff Depth (Pervious)	0.5 in
Runoff Volume (Pervious)	0.007 ac-ft

Hydrograph Volume (Area under Hydrograph curve)	
Volume	0.007 ac-ft

SCS Unit Hydrograph Parameters	
Time of Concentration (Composite)	0.167 hours
Computational Time Increment	0.022 hours
Unit Hydrograph Shape Factor	483.432
K Factor	0.749
Receding/Rising, Tr/Tp	1.670
Unit peak, qp	1.09 ft <sup>3</sup> /s
Unit peak time, Tp	0.111 hours

Subsection: Unit Hydrograph Summary  
Label: Post-Development DA-2 Bypass

Return Event: 1 years  
Storm Event: 1-Year

---

SCS Unit Hydrograph Parameters

---

Unit receding limb, Tr	0.444 hours
Total unit time, Tb	0.556 hours

---

Subsection: Unit Hydrograph Summary  
 Label: Post-Development DA-2 Bypass

Return Event: 10 years  
 Storm Event: 10-Year

Storm Event	10-Year
Return Event	10 years
Duration	24.000 hours
Depth	3.8 in
Time of Concentration (Composite)	0.167 hours
Area (User Defined)	0.160 acres

Computational Time Increment	0.022 hours
Time to Peak (Computed)	12.000 hours
Flow (Peak, Computed)	0.39 ft <sup>3</sup> /s
Output Increment	0.050 hours
Time to Flow (Peak Interpolated Output)	12.000 hours
Flow (Peak Interpolated Output)	0.39 ft <sup>3</sup> /s

Drainage Area	
SCS CN (Composite)	78.000
Area (User Defined)	0.160 acres
Maximum Retention (Pervious)	2.8 in
Maximum Retention (Pervious, 20 percent)	0.6 in

Cumulative Runoff	
Cumulative Runoff Depth (Pervious)	1.8 in
Runoff Volume (Pervious)	0.023 ac-ft

Hydrograph Volume (Area under Hydrograph curve)	
Volume	0.023 ac-ft

SCS Unit Hydrograph Parameters	
Time of Concentration (Composite)	0.167 hours
Computational Time Increment	0.022 hours
Unit Hydrograph Shape Factor	483.432
K Factor	0.749
Receding/Rising, Tr/Tp	1.670
Unit peak, qp	1.09 ft <sup>3</sup> /s
Unit peak time, Tp	0.111 hours

Subsection: Unit Hydrograph Summary  
Label: Post-Development DA-2 Bypass

Return Event: 10 years  
Storm Event: 10-Year

---

SCS Unit Hydrograph Parameters

---

Unit receding limb, Tr	0.444 hours
Total unit time, Tb	0.556 hours

---

Subsection: Unit Hydrograph Summary  
 Label: Post-Development DA-2 Bypass

Return Event: 25 years  
 Storm Event: 25-Year

Storm Event	25-Year
Return Event	25 years
Duration	24.000 hours
Depth	4.7 in
Time of Concentration (Composite)	0.167 hours
Area (User Defined)	0.160 acres

Computational Time Increment	0.022 hours
Time to Peak (Computed)	12.000 hours
Flow (Peak, Computed)	0.54 ft <sup>3</sup> /s
Output Increment	0.050 hours
Time to Flow (Peak Interpolated Output)	12.000 hours
Flow (Peak Interpolated Output)	0.54 ft <sup>3</sup> /s

Drainage Area	
SCS CN (Composite)	78.000
Area (User Defined)	0.160 acres
Maximum Retention (Pervious)	2.8 in
Maximum Retention (Pervious, 20 percent)	0.6 in

Cumulative Runoff	
Cumulative Runoff Depth (Pervious)	2.5 in
Runoff Volume (Pervious)	0.033 ac-ft

Hydrograph Volume (Area under Hydrograph curve)	
Volume	0.033 ac-ft

SCS Unit Hydrograph Parameters	
Time of Concentration (Composite)	0.167 hours
Computational Time Increment	0.022 hours
Unit Hydrograph Shape Factor	483.432
K Factor	0.749
Receding/Rising, Tr/Tp	1.670
Unit peak, qp	1.09 ft <sup>3</sup> /s
Unit peak time, Tp	0.111 hours



Subsection: Unit Hydrograph Summary  
Label: Post-Development DA-2 Bypass

Return Event: 25 years  
Storm Event: 25-Year

---

SCS Unit Hydrograph Parameters

---

Unit receding limb, Tr	0.444 hours
Total unit time, Tb	0.556 hours

---

Subsection: Unit Hydrograph Summary  
 Label: Post-Development DA-2 Bypass

Return Event: 100 years  
 Storm Event: 100-Year

Storm Event	100-Year
Return Event	100 years
Duration	24.000 hours
Depth	6.0 in
Time of Concentration (Composite)	0.167 hours
Area (User Defined)	0.160 acres

Computational Time Increment	0.022 hours
Time to Peak (Computed)	11.978 hours
Flow (Peak, Computed)	0.78 ft <sup>3</sup> /s
Output Increment	0.050 hours
Time to Flow (Peak Interpolated Output)	12.000 hours
Flow (Peak Interpolated Output)	0.78 ft <sup>3</sup> /s

Drainage Area	
SCS CN (Composite)	78.000
Area (User Defined)	0.160 acres
Maximum Retention (Pervious)	2.8 in
Maximum Retention (Pervious, 20 percent)	0.6 in

Cumulative Runoff	
Cumulative Runoff Depth (Pervious)	3.6 in
Runoff Volume (Pervious)	0.048 ac-ft

Hydrograph Volume (Area under Hydrograph curve)	
Volume	0.048 ac-ft

SCS Unit Hydrograph Parameters	
Time of Concentration (Composite)	0.167 hours
Computational Time Increment	0.022 hours
Unit Hydrograph Shape Factor	483.432
K Factor	0.749
Receding/Rising, Tr/Tp	1.670
Unit peak, qp	1.09 ft <sup>3</sup> /s
Unit peak time, Tp	0.111 hours

Subsection: Unit Hydrograph Summary  
Label: Post-Development DA-2 Bypass

Return Event: 100 years  
Storm Event: 100-Year

---

SCS Unit Hydrograph Parameters

---

Unit receding limb, Tr	0.444 hours
Total unit time, Tb	0.556 hours

---

Subsection: Unit Hydrograph Summary  
 Label: Post-Development DA-2 Offsite

Return Event: 1 years  
 Storm Event: 1-Year

Storm Event	1-Year
Return Event	1 years
Duration	24.000 hours
Depth	2.0 in
Time of Concentration (Composite)	0.600 hours
Area (User Defined)	108.040 acres

Computational Time Increment	0.080 hours
Time to Peak (Computed)	12.320 hours
Flow (Peak, Computed)	33.91 ft <sup>3</sup> /s
Output Increment	0.050 hours
Time to Flow (Peak Interpolated Output)	12.300 hours
Flow (Peak Interpolated Output)	33.86 ft <sup>3</sup> /s

Drainage Area	
SCS CN (Composite)	78.000
Area (User Defined)	108.040 acres
Maximum Retention (Pervious)	2.8 in
Maximum Retention (Pervious, 20 percent)	0.6 in

Cumulative Runoff	
Cumulative Runoff Depth (Pervious)	0.5 in
Runoff Volume (Pervious)	4.412 ac-ft

Hydrograph Volume (Area under Hydrograph curve)	
Volume	4.358 ac-ft

SCS Unit Hydrograph Parameters	
Time of Concentration (Composite)	0.600 hours
Computational Time Increment	0.080 hours
Unit Hydrograph Shape Factor	483.432
K Factor	0.749
Receding/Rising, Tr/Tp	1.670
Unit peak, qp	204.02 ft <sup>3</sup> /s
Unit peak time, Tp	0.400 hours

Subsection: Unit Hydrograph Summary  
Label: Post-Development DA-2 Offsite

Return Event: 1 years  
Storm Event: 1-Year

---

SCS Unit Hydrograph Parameters

---

Unit receding limb, Tr	1.600 hours
Total unit time, Tb	2.000 hours

---

Subsection: Unit Hydrograph Summary  
 Label: Post-Development DA-2 Offsite

Return Event: 10 years  
 Storm Event: 10-Year

Storm Event	10-Year
Return Event	10 years
Duration	24.000 hours
Depth	3.8 in
Time of Concentration (Composite)	0.600 hours
Area (User Defined)	108.040 acres

Computational Time Increment	0.080 hours
Time to Peak (Computed)	12.240 hours
Flow (Peak, Computed)	142.70 ft <sup>3</sup> /s
Output Increment	0.050 hours
Time to Flow (Peak Interpolated Output)	12.250 hours
Flow (Peak Interpolated Output)	142.00 ft <sup>3</sup> /s

Drainage Area	
SCS CN (Composite)	78.000
Area (User Defined)	108.040 acres
Maximum Retention (Pervious)	2.8 in
Maximum Retention (Pervious, 20 percent)	0.6 in

Cumulative Runoff	
Cumulative Runoff Depth (Pervious)	1.8 in
Runoff Volume (Pervious)	15.849 ac-ft

Hydrograph Volume (Area under Hydrograph curve)	
Volume	15.704 ac-ft

SCS Unit Hydrograph Parameters	
Time of Concentration (Composite)	0.600 hours
Computational Time Increment	0.080 hours
Unit Hydrograph Shape Factor	483.432
K Factor	0.749
Receding/Rising, Tr/Tp	1.670
Unit peak, qp	204.02 ft <sup>3</sup> /s
Unit peak time, Tp	0.400 hours

Subsection: Unit Hydrograph Summary  
Label: Post-Development DA-2 Offsite

Return Event: 10 years  
Storm Event: 10-Year

---

SCS Unit Hydrograph Parameters

---

Unit receding limb, Tr	1.600 hours
Total unit time, Tb	2.000 hours

---

Subsection: Unit Hydrograph Summary  
 Label: Post-Development DA-2 Offsite

Return Event: 25 years  
 Storm Event: 25-Year

Storm Event	25-Year
Return Event	25 years
Duration	24.000 hours
Depth	4.7 in
Time of Concentration (Composite)	0.600 hours
Area (User Defined)	108.040 acres

Computational Time Increment	0.080 hours
Time to Peak (Computed)	12.240 hours
Flow (Peak, Computed)	201.74 ft <sup>3</sup> /s
Output Increment	0.050 hours
Time to Flow (Peak Interpolated Output)	12.250 hours
Flow (Peak Interpolated Output)	200.59 ft <sup>3</sup> /s

Drainage Area	
SCS CN (Composite)	78.000
Area (User Defined)	108.040 acres
Maximum Retention (Pervious)	2.8 in
Maximum Retention (Pervious, 20 percent)	0.6 in

Cumulative Runoff	
Cumulative Runoff Depth (Pervious)	2.5 in
Runoff Volume (Pervious)	22.139 ac-ft

Hydrograph Volume (Area under Hydrograph curve)	
Volume	21.951 ac-ft

SCS Unit Hydrograph Parameters	
Time of Concentration (Composite)	0.600 hours
Computational Time Increment	0.080 hours
Unit Hydrograph Shape Factor	483.432
K Factor	0.749
Receding/Rising, Tr/Tp	1.670
Unit peak, qp	204.02 ft <sup>3</sup> /s
Unit peak time, Tp	0.400 hours



Subsection: Unit Hydrograph Summary  
Label: Post-Development DA-2 Offsite

Return Event: 25 years  
Storm Event: 25-Year

---

SCS Unit Hydrograph Parameters

---

Unit receding limb, Tr	1.600 hours
Total unit time, Tb	2.000 hours

---

Subsection: Unit Hydrograph Summary  
 Label: Post-Development DA-2 Offsite

Return Event: 100 years  
 Storm Event: 100-Year

Storm Event	100-Year
Return Event	100 years
Duration	24.000 hours
Depth	6.0 in
Time of Concentration (Composite)	0.600 hours
Area (User Defined)	108.040 acres

Computational Time Increment	0.080 hours
Time to Peak (Computed)	12.240 hours
Flow (Peak, Computed)	296.47 ft <sup>3</sup> /s
Output Increment	0.050 hours
Time to Flow (Peak Interpolated Output)	12.250 hours
Flow (Peak Interpolated Output)	294.53 ft <sup>3</sup> /s

Drainage Area	
SCS CN (Composite)	78.000
Area (User Defined)	108.040 acres
Maximum Retention (Pervious)	2.8 in
Maximum Retention (Pervious, 20 percent)	0.6 in

Cumulative Runoff	
Cumulative Runoff Depth (Pervious)	3.6 in
Runoff Volume (Pervious)	32.382 ac-ft

Hydrograph Volume (Area under Hydrograph curve)	
Volume	32.126 ac-ft

SCS Unit Hydrograph Parameters	
Time of Concentration (Composite)	0.600 hours
Computational Time Increment	0.080 hours
Unit Hydrograph Shape Factor	483.432
K Factor	0.749
Receding/Rising, Tr/Tp	1.670
Unit peak, qp	204.02 ft <sup>3</sup> /s
Unit peak time, Tp	0.400 hours

Subsection: Unit Hydrograph Summary  
Label: Post-Development DA-2 Offsite

Return Event: 100 years  
Storm Event: 100-Year

---

SCS Unit Hydrograph Parameters

---

Unit receding limb, Tr	1.600 hours
Total unit time, Tb	2.000 hours

---

Subsection: Unit Hydrograph Summary  
 Label: Post-Development DA-3

Return Event: 1 years  
 Storm Event: 1-Year

Storm Event	1-Year
Return Event	1 years
Duration	24.000 hours
Depth	2.0 in
Time of Concentration (Composite)	0.083 hours
Area (User Defined)	1.590 acres

Computational Time Increment	0.011 hours
Time to Peak (Computed)	11.922 hours
Flow (Peak, Computed)	2.77 ft <sup>3</sup> /s
Output Increment	0.050 hours
Time to Flow (Peak Interpolated Output)	11.900 hours
Flow (Peak Interpolated Output)	2.65 ft <sup>3</sup> /s

Drainage Area	
SCS CN (Composite)	90.000
Area (User Defined)	1.590 acres
Maximum Retention (Pervious)	1.1 in
Maximum Retention (Pervious, 20 percent)	0.2 in

Cumulative Runoff	
Cumulative Runoff Depth (Pervious)	1.1 in
Runoff Volume (Pervious)	0.146 ac-ft

Hydrograph Volume (Area under Hydrograph curve)	
Volume	0.146 ac-ft

SCS Unit Hydrograph Parameters	
Time of Concentration (Composite)	0.083 hours
Computational Time Increment	0.011 hours
Unit Hydrograph Shape Factor	483.432
K Factor	0.749
Receding/Rising, Tr/Tp	1.670
Unit peak, qp	21.62 ft <sup>3</sup> /s
Unit peak time, Tp	0.056 hours

Subsection: Unit Hydrograph Summary  
Label: Post-Development DA-3

Return Event: 1 years  
Storm Event: 1-Year

---

SCS Unit Hydrograph Parameters	
Unit receding limb, Tr	0.222 hours
Total unit time, Tb	0.278 hours

---

Subsection: Unit Hydrograph Summary  
 Label: Post-Development DA-3

Return Event: 10 years  
 Storm Event: 10-Year

Storm Event	10-Year
Return Event	10 years
Duration	24.000 hours
Depth	3.8 in
Time of Concentration (Composite)	0.083 hours
Area (User Defined)	1.590 acres

Computational Time Increment	0.011 hours
Time to Peak (Computed)	11.922 hours
Flow (Peak, Computed)	6.76 ft <sup>3</sup> /s
Output Increment	0.050 hours
Time to Flow (Peak Interpolated Output)	11.900 hours
Flow (Peak Interpolated Output)	6.57 ft <sup>3</sup> /s

Drainage Area	
SCS CN (Composite)	90.000
Area (User Defined)	1.590 acres
Maximum Retention (Pervious)	1.1 in
Maximum Retention (Pervious, 20 percent)	0.2 in

Cumulative Runoff	
Cumulative Runoff Depth (Pervious)	2.8 in
Runoff Volume (Pervious)	0.367 ac-ft

Hydrograph Volume (Area under Hydrograph curve)	
Volume	0.366 ac-ft

SCS Unit Hydrograph Parameters	
Time of Concentration (Composite)	0.083 hours
Computational Time Increment	0.011 hours
Unit Hydrograph Shape Factor	483.432
K Factor	0.749
Receding/Rising, Tr/Tp	1.670
Unit peak, qp	21.62 ft <sup>3</sup> /s
Unit peak time, Tp	0.056 hours

Subsection: Unit Hydrograph Summary  
Label: Post-Development DA-3

Return Event: 10 years  
Storm Event: 10-Year

---

SCS Unit Hydrograph Parameters	
Unit receding limb, Tr	0.222 hours
Total unit time, Tb	0.278 hours

---

Subsection: Unit Hydrograph Summary  
 Label: Post-Development DA-3

Return Event: 25 years  
 Storm Event: 25-Year

Storm Event	25-Year
Return Event	25 years
Duration	24.000 hours
Depth	4.7 in
Time of Concentration (Composite)	0.083 hours
Area (User Defined)	1.590 acres
<hr/>	
Computational Time Increment	0.011 hours
Time to Peak (Computed)	11.922 hours
Flow (Peak, Computed)	8.65 ft <sup>3</sup> /s
Output Increment	0.050 hours
Time to Flow (Peak Interpolated Output)	11.900 hours
Flow (Peak Interpolated Output)	8.43 ft <sup>3</sup> /s
<hr/>	
Drainage Area	
SCS CN (Composite)	90.000
Area (User Defined)	1.590 acres
Maximum Retention (Pervious)	1.1 in
Maximum Retention (Pervious, 20 percent)	0.2 in
<hr/>	
Cumulative Runoff	
Cumulative Runoff Depth (Pervious)	3.6 in
Runoff Volume (Pervious)	0.475 ac-ft
<hr/>	
Hydrograph Volume (Area under Hydrograph curve)	
Volume	0.475 ac-ft
<hr/>	
SCS Unit Hydrograph Parameters	
Time of Concentration (Composite)	0.083 hours
Computational Time Increment	0.011 hours
Unit Hydrograph Shape Factor	483.432
K Factor	0.749
Receding/Rising, Tr/Tp	1.670
Unit peak, qp	21.62 ft <sup>3</sup> /s
Unit peak time, Tp	0.056 hours



Subsection: Unit Hydrograph Summary  
Label: Post-Development DA-3

Return Event: 25 years  
Storm Event: 25-Year

---

SCS Unit Hydrograph Parameters	
Unit receding limb, Tr	0.222 hours
Total unit time, Tb	0.278 hours

---

Subsection: Unit Hydrograph Summary  
 Label: Post-Development DA-3

Return Event: 100 years  
 Storm Event: 100-Year

Storm Event	100-Year
Return Event	100 years
Duration	24.000 hours
Depth	6.0 in
Time of Concentration (Composite)	0.083 hours
Area (User Defined)	1.590 acres
<hr/>	
Computational Time Increment	0.011 hours
Time to Peak (Computed)	11.922 hours
Flow (Peak, Computed)	11.52 ft <sup>3</sup> /s
Output Increment	0.050 hours
Time to Flow (Peak Interpolated Output)	11.900 hours
Flow (Peak Interpolated Output)	11.27 ft <sup>3</sup> /s
<hr/>	
Drainage Area	
SCS CN (Composite)	90.000
Area (User Defined)	1.590 acres
Maximum Retention (Pervious)	1.1 in
Maximum Retention (Pervious, 20 percent)	0.2 in
<hr/>	
Cumulative Runoff	
Cumulative Runoff Depth (Pervious)	4.9 in
Runoff Volume (Pervious)	0.645 ac-ft
<hr/>	
Hydrograph Volume (Area under Hydrograph curve)	
Volume	0.644 ac-ft
<hr/>	
SCS Unit Hydrograph Parameters	
Time of Concentration (Composite)	0.083 hours
Computational Time Increment	0.011 hours
Unit Hydrograph Shape Factor	483.432
K Factor	0.749
Receding/Rising, Tr/Tp	1.670
Unit peak, qp	21.62 ft <sup>3</sup> /s
Unit peak time, Tp	0.056 hours

Subsection: Unit Hydrograph Summary  
Label: Post-Development DA-3

Return Event: 100 years  
Storm Event: 100-Year

---

SCS Unit Hydrograph Parameters	
Unit receding limb, Tr	0.222 hours
Total unit time, Tb	0.278 hours

---

Subsection: Unit Hydrograph Summary  
 Label: Post-Development DA-3 Bypass

Return Event: 1 years  
 Storm Event: 1-Year

Storm Event	1-Year
Return Event	1 years
Duration	24.000 hours
Depth	2.0 in
Time of Concentration (Composite)	0.200 hours
Area (User Defined)	2.880 acres
<hr/>	
Computational Time Increment	0.027 hours
Time to Peak (Computed)	12.027 hours
Flow (Peak, Computed)	3.01 ft <sup>3</sup> /s
Output Increment	0.050 hours
Time to Flow (Peak Interpolated Output)	12.000 hours
Flow (Peak Interpolated Output)	2.96 ft <sup>3</sup> /s
<hr/>	
Drainage Area	
SCS CN (Composite)	85.000
Area (User Defined)	2.880 acres
Maximum Retention (Pervious)	1.8 in
Maximum Retention (Pervious, 20 percent)	0.4 in
<hr/>	
Cumulative Runoff	
Cumulative Runoff Depth (Pervious)	0.8 in
Runoff Volume (Pervious)	0.193 ac-ft
<hr/>	
Hydrograph Volume (Area under Hydrograph curve)	
Volume	0.192 ac-ft
<hr/>	
SCS Unit Hydrograph Parameters	
Time of Concentration (Composite)	0.200 hours
Computational Time Increment	0.027 hours
Unit Hydrograph Shape Factor	483.432
K Factor	0.749
Receding/Rising, Tr/Tp	1.670
Unit peak, qp	16.32 ft <sup>3</sup> /s
Unit peak time, Tp	0.133 hours

Subsection: Unit Hydrograph Summary  
Label: Post-Development DA-3 Bypass

Return Event: 1 years  
Storm Event: 1-Year

---

SCS Unit Hydrograph Parameters	
Unit receding limb, Tr	0.533 hours
Total unit time, Tb	0.667 hours

---

Subsection: Unit Hydrograph Summary  
 Label: Post-Development DA-3 Bypass

Return Event: 10 years  
 Storm Event: 10-Year

Storm Event	10-Year
Return Event	10 years
Duration	24.000 hours
Depth	3.8 in
Time of Concentration (Composite)	0.200 hours
Area (User Defined)	2.880 acres
<hr/>	
Computational Time Increment	0.027 hours
Time to Peak (Computed)	12.000 hours
Flow (Peak, Computed)	8.66 ft <sup>3</sup> /s
Output Increment	0.050 hours
Time to Flow (Peak Interpolated Output)	12.000 hours
Flow (Peak Interpolated Output)	8.66 ft <sup>3</sup> /s
<hr/>	
Drainage Area	
SCS CN (Composite)	85.000
Area (User Defined)	2.880 acres
Maximum Retention (Pervious)	1.8 in
Maximum Retention (Pervious, 20 percent)	0.4 in
<hr/>	
Cumulative Runoff	
Cumulative Runoff Depth (Pervious)	2.3 in
Runoff Volume (Pervious)	0.556 ac-ft
<hr/>	
Hydrograph Volume (Area under Hydrograph curve)	
Volume	0.555 ac-ft
<hr/>	
SCS Unit Hydrograph Parameters	
Time of Concentration (Composite)	0.200 hours
Computational Time Increment	0.027 hours
Unit Hydrograph Shape Factor	483.432
K Factor	0.749
Receding/Rising, Tr/Tp	1.670
Unit peak, qp	16.32 ft <sup>3</sup> /s
Unit peak time, Tp	0.133 hours

Subsection: Unit Hydrograph Summary  
Label: Post-Development DA-3 Bypass

Return Event: 10 years  
Storm Event: 10-Year

---

SCS Unit Hydrograph Parameters

---

Unit receding limb, Tr	0.533 hours
Total unit time, Tb	0.667 hours

---

Subsection: Unit Hydrograph Summary  
 Label: Post-Development DA-3 Bypass

Return Event: 25 years  
 Storm Event: 25-Year

Storm Event	25-Year
Return Event	25 years
Duration	24.000 hours
Depth	4.7 in
Time of Concentration (Composite)	0.200 hours
Area (User Defined)	2.880 acres
<hr/>	
Computational Time Increment	0.027 hours
Time to Peak (Computed)	12.000 hours
Flow (Peak, Computed)	11.49 ft <sup>3</sup> /s
Output Increment	0.050 hours
Time to Flow (Peak Interpolated Output)	12.000 hours
Flow (Peak Interpolated Output)	11.49 ft <sup>3</sup> /s
<hr/>	
Drainage Area	
SCS CN (Composite)	85.000
Area (User Defined)	2.880 acres
Maximum Retention (Pervious)	1.8 in
Maximum Retention (Pervious, 20 percent)	0.4 in
<hr/>	
Cumulative Runoff	
Cumulative Runoff Depth (Pervious)	3.1 in
Runoff Volume (Pervious)	0.742 ac-ft
<hr/>	
Hydrograph Volume (Area under Hydrograph curve)	
Volume	0.741 ac-ft
<hr/>	
SCS Unit Hydrograph Parameters	
Time of Concentration (Composite)	0.200 hours
Computational Time Increment	0.027 hours
Unit Hydrograph Shape Factor	483.432
K Factor	0.749
Receding/Rising, Tr/Tp	1.670
Unit peak, qp	16.32 ft <sup>3</sup> /s
Unit peak time, Tp	0.133 hours



Subsection: Unit Hydrograph Summary  
Label: Post-Development DA-3 Bypass

Return Event: 25 years  
Storm Event: 25-Year

---

SCS Unit Hydrograph Parameters

---

Unit receding limb, Tr	0.533 hours
Total unit time, Tb	0.667 hours

---

Subsection: Unit Hydrograph Summary  
 Label: Post-Development DA-3 Bypass

Return Event: 100 years  
 Storm Event: 100-Year

Storm Event	100-Year
Return Event	100 years
Duration	24.000 hours
Depth	6.0 in
Time of Concentration (Composite)	0.200 hours
Area (User Defined)	2.880 acres
<hr/>	
Computational Time Increment	0.027 hours
Time to Peak (Computed)	12.000 hours
Flow (Peak, Computed)	15.86 ft <sup>3</sup> /s
Output Increment	0.050 hours
Time to Flow (Peak Interpolated Output)	12.000 hours
Flow (Peak Interpolated Output)	15.86 ft <sup>3</sup> /s
<hr/>	
Drainage Area	
SCS CN (Composite)	85.000
Area (User Defined)	2.880 acres
Maximum Retention (Pervious)	1.8 in
Maximum Retention (Pervious, 20 percent)	0.4 in
<hr/>	
Cumulative Runoff	
Cumulative Runoff Depth (Pervious)	4.3 in
Runoff Volume (Pervious)	1.037 ac-ft
<hr/>	
Hydrograph Volume (Area under Hydrograph curve)	
Volume	1.035 ac-ft
<hr/>	
SCS Unit Hydrograph Parameters	
Time of Concentration (Composite)	0.200 hours
Computational Time Increment	0.027 hours
Unit Hydrograph Shape Factor	483.432
K Factor	0.749
Receding/Rising, Tr/Tp	1.670
Unit peak, qp	16.32 ft <sup>3</sup> /s
Unit peak time, Tp	0.133 hours

Subsection: Unit Hydrograph Summary  
Label: Post-Development DA-3 Bypass

Return Event: 100 years  
Storm Event: 100-Year

---

SCS Unit Hydrograph Parameters

---

Unit receding limb, Tr	0.533 hours
Total unit time, Tb	0.667 hours

---

Subsection: Unit Hydrograph Summary  
 Label: Post-Development DA-3 Offsite

Return Event: 1 years  
 Storm Event: 1-Year

Storm Event	1-Year
Return Event	1 years
Duration	24.000 hours
Depth	2.0 in
Time of Concentration (Composite)	0.400 hours
Area (User Defined)	6.130 acres

Computational Time Increment	0.053 hours
Time to Peak (Computed)	12.160 hours
Flow (Peak, Computed)	2.56 ft <sup>3</sup> /s
Output Increment	0.050 hours
Time to Flow (Peak Interpolated Output)	12.150 hours
Flow (Peak Interpolated Output)	2.54 ft <sup>3</sup> /s

Drainage Area	
SCS CN (Composite)	78.000
Area (User Defined)	6.130 acres
Maximum Retention (Pervious)	2.8 in
Maximum Retention (Pervious, 20 percent)	0.6 in

Cumulative Runoff	
Cumulative Runoff Depth (Pervious)	0.5 in
Runoff Volume (Pervious)	0.250 ac-ft

Hydrograph Volume (Area under Hydrograph curve)	
Volume	0.248 ac-ft

SCS Unit Hydrograph Parameters	
Time of Concentration (Composite)	0.400 hours
Computational Time Increment	0.053 hours
Unit Hydrograph Shape Factor	483.432
K Factor	0.749
Receding/Rising, Tr/Tp	1.670
Unit peak, qp	17.36 ft <sup>3</sup> /s
Unit peak time, Tp	0.267 hours

Subsection: Unit Hydrograph Summary  
Label: Post-Development DA-3 Offsite

Return Event: 1 years  
Storm Event: 1-Year

---

SCS Unit Hydrograph Parameters	
Unit receding limb, Tr	1.067 hours
Total unit time, Tb	1.333 hours

---

Subsection: Unit Hydrograph Summary  
 Label: Post-Development DA-3 Offsite

Return Event: 10 years  
 Storm Event: 10-Year

Storm Event	10-Year
Return Event	10 years
Duration	24.000 hours
Depth	3.8 in
Time of Concentration (Composite)	0.400 hours
Area (User Defined)	6.130 acres

Computational Time Increment	0.053 hours
Time to Peak (Computed)	12.107 hours
Flow (Peak, Computed)	10.34 ft <sup>3</sup> /s
Output Increment	0.050 hours
Time to Flow (Peak Interpolated Output)	12.150 hours
Flow (Peak Interpolated Output)	10.30 ft <sup>3</sup> /s

Drainage Area	
SCS CN (Composite)	78.000
Area (User Defined)	6.130 acres
Maximum Retention (Pervious)	2.8 in
Maximum Retention (Pervious, 20 percent)	0.6 in

Cumulative Runoff	
Cumulative Runoff Depth (Pervious)	1.8 in
Runoff Volume (Pervious)	0.899 ac-ft

Hydrograph Volume (Area under Hydrograph curve)	
Volume	0.894 ac-ft

SCS Unit Hydrograph Parameters	
Time of Concentration (Composite)	0.400 hours
Computational Time Increment	0.053 hours
Unit Hydrograph Shape Factor	483.432
K Factor	0.749
Receding/Rising, Tr/Tp	1.670
Unit peak, qp	17.36 ft <sup>3</sup> /s
Unit peak time, Tp	0.267 hours

Subsection: Unit Hydrograph Summary  
Label: Post-Development DA-3 Offsite

Return Event: 10 years  
Storm Event: 10-Year

---

SCS Unit Hydrograph Parameters	
Unit receding limb, Tr	1.067 hours
Total unit time, Tb	1.333 hours

---

Subsection: Unit Hydrograph Summary  
 Label: Post-Development DA-3 Offsite

Return Event: 25 years  
 Storm Event: 25-Year

Storm Event	25-Year
Return Event	25 years
Duration	24.000 hours
Depth	4.7 in
Time of Concentration (Composite)	0.400 hours
Area (User Defined)	6.130 acres
<hr/>	
Computational Time Increment	0.053 hours
Time to Peak (Computed)	12.107 hours
Flow (Peak, Computed)	14.60 ft <sup>3</sup> /s
Output Increment	0.050 hours
Time to Flow (Peak Interpolated Output)	12.150 hours
Flow (Peak Interpolated Output)	14.46 ft <sup>3</sup> /s
<hr/>	
Drainage Area	
SCS CN (Composite)	78.000
Area (User Defined)	6.130 acres
Maximum Retention (Pervious)	2.8 in
Maximum Retention (Pervious, 20 percent)	0.6 in
<hr/>	
Cumulative Runoff	
Cumulative Runoff Depth (Pervious)	2.5 in
Runoff Volume (Pervious)	1.256 ac-ft
<hr/>	
Hydrograph Volume (Area under Hydrograph curve)	
Volume	1.250 ac-ft
<hr/>	
SCS Unit Hydrograph Parameters	
Time of Concentration (Composite)	0.400 hours
Computational Time Increment	0.053 hours
Unit Hydrograph Shape Factor	483.432
K Factor	0.749
Receding/Rising, Tr/Tp	1.670
Unit peak, qp	17.36 ft <sup>3</sup> /s
Unit peak time, Tp	0.267 hours



Subsection: Unit Hydrograph Summary  
Label: Post-Development DA-3 Offsite

Return Event: 25 years  
Storm Event: 25-Year

---

SCS Unit Hydrograph Parameters	
Unit receding limb, Tr	1.067 hours
Total unit time, Tb	1.333 hours

---

Subsection: Unit Hydrograph Summary  
 Label: Post-Development DA-3 Offsite

Return Event: 100 years  
 Storm Event: 100-Year

Storm Event	100-Year
Return Event	100 years
Duration	24.000 hours
Depth	6.0 in
Time of Concentration (Composite)	0.400 hours
Area (User Defined)	6.130 acres

Computational Time Increment	0.053 hours
Time to Peak (Computed)	12.107 hours
Flow (Peak, Computed)	21.43 ft <sup>3</sup> /s
Output Increment	0.050 hours
Time to Flow (Peak Interpolated Output)	12.100 hours
Flow (Peak Interpolated Output)	21.24 ft <sup>3</sup> /s

Drainage Area	
SCS CN (Composite)	78.000
Area (User Defined)	6.130 acres
Maximum Retention (Pervious)	2.8 in
Maximum Retention (Pervious, 20 percent)	0.6 in

Cumulative Runoff	
Cumulative Runoff Depth (Pervious)	3.6 in
Runoff Volume (Pervious)	1.837 ac-ft

Hydrograph Volume (Area under Hydrograph curve)	
Volume	1.829 ac-ft

SCS Unit Hydrograph Parameters	
Time of Concentration (Composite)	0.400 hours
Computational Time Increment	0.053 hours
Unit Hydrograph Shape Factor	483.432
K Factor	0.749
Receding/Rising, Tr/Tp	1.670
Unit peak, qp	17.36 ft <sup>3</sup> /s
Unit peak time, Tp	0.267 hours

Subsection: Unit Hydrograph Summary  
Label: Post-Development DA-3 Offsite

Return Event: 100 years  
Storm Event: 100-Year

---

SCS Unit Hydrograph Parameters

---

Unit receding limb, Tr	1.067 hours
Total unit time, Tb	1.333 hours

---

# Index

## I

Ithaca (Time-Depth Curve, 1 years)...10, 11

Ithaca (Time-Depth Curve, 10 years)...8, 9

Ithaca (Time-Depth Curve, 100 years)...6, 7

Ithaca (Time-Depth Curve, 25 years)...12, 13

## M

Master Network Summary...2, 3, 4, 5

## P

Post-Development DA-1 (Unit Hydrograph Summary, 1 years)...16, 17

Post-Development DA-1 (Unit Hydrograph Summary, 10 years)...18, 19

Post-Development DA-1 (Unit Hydrograph Summary, 100 years)...22, 23

Post-Development DA-1 (Unit Hydrograph Summary, 25 years)...20, 21

Post-Development DA-1 Bypass (Unit Hydrograph Summary, 1 years)...24, 25

Post-Development DA-1 Bypass (Unit Hydrograph Summary, 10 years)...26, 27

Post-Development DA-1 Bypass (Unit Hydrograph Summary, 100 years)...30, 31

Post-Development DA-1 Bypass (Unit Hydrograph Summary, 25 years)...28, 29

Post-Development DA-1 Offsite (Unit Hydrograph Summary, 1 years)...32, 33

Post-Development DA-1 Offsite (Unit Hydrograph Summary, 10 years)...34, 35

Post-Development DA-1 Offsite (Unit Hydrograph Summary, 100 years)...38, 39

Post-Development DA-1 Offsite (Unit Hydrograph Summary, 25 years)...36, 37

Post-Development DA-2 (Unit Hydrograph Summary, 1 years)...40, 41

Post-Development DA-2 (Unit Hydrograph Summary, 10 years)...42, 43

Post-Development DA-2 (Unit Hydrograph Summary, 100 years)...46, 47

Post-Development DA-2 (Unit Hydrograph Summary, 25 years)...44, 45

Post-Development DA-2 Bypass (Unit Hydrograph Summary, 1 years)...48, 49

Post-Development DA-2 Bypass (Unit Hydrograph Summary, 10 years)...50, 51

Post-Development DA-2 Bypass (Unit Hydrograph Summary, 100 years)...54, 55

Post-Development DA-2 Bypass (Unit Hydrograph Summary, 25 years)...52, 53

Post-Development DA-2 Offsite (Unit Hydrograph Summary, 1 years)...56, 57

Post-Development DA-2 Offsite (Unit Hydrograph Summary, 10 years)...58, 59

Post-Development DA-2 Offsite (Unit Hydrograph Summary, 100 years)...62, 63

Post-Development DA-2 Offsite (Unit Hydrograph Summary, 25 years)...60, 61  
Post-Development DA-3 (Unit Hydrograph Summary, 1 years)...64, 65  
Post-Development DA-3 (Unit Hydrograph Summary, 10 years)...66, 67  
Post-Development DA-3 (Unit Hydrograph Summary, 100 years)...70, 71  
Post-Development DA-3 (Unit Hydrograph Summary, 25 years)...68, 69  
Post-Development DA-3 Bypass (Unit Hydrograph Summary, 1 years)...72, 73  
Post-Development DA-3 Bypass (Unit Hydrograph Summary, 10 years)...74, 75  
Post-Development DA-3 Bypass (Unit Hydrograph Summary, 100 years)...78, 79  
Post-Development DA-3 Bypass (Unit Hydrograph Summary, 25 years)...76, 77  
Post-Development DA-3 Offsite (Unit Hydrograph Summary, 1 years)...80, 81  
Post-Development DA-3 Offsite (Unit Hydrograph Summary, 10 years)...82, 83  
Post-Development DA-3 Offsite (Unit Hydrograph Summary, 100 years)...86, 87  
Post-Development DA-3 Offsite (Unit Hydrograph Summary, 25 years)...84, 85  
U  
Unit Hydrograph Equations...14, 15

## **APPENDIX I**

### **Rip Rap Apron and Sediment Trap Calculations**

**APPENDIX J**  
**Geotechnical Report**



Intertek-PSI  
3784 Commerce Court  
Suite 300  
North Tonawanda, NY 14120

Tel +1 716 694 8657  
Fax +1 716 694 8638  
[intertek.com/building](http://intertek.com/building)

August 8, 2018

Trinitas Ventures, LLC  
201 Main Street, Suite 1000  
Lafayette, IN 47901  
Attn.: Ms. Kimberly Hansen  
Manager, Design & Development

Subject: **Preliminary Geotechnical Engineering Services Addendum Report  
Proposed Student Housing Development  
Seven (7) Parcels in the vicinity of 959 Dryden Road  
Ithaca, Tompkins County, New York 14850  
PSI Project No.: 0806962 – Addendum Report**

Dear Ms. Hansen:

Thank you for choosing Professional Service Industries Engineering, PLLC (PSIE, PLLC) as your consultant for the above referenced project.

Per your authorization, Professional Service Industries Engineering, PLLC has completed a Preliminary Geotechnical Engineering Study for the above referenced project. The results of the study are discussed in the accompanying report. An electronic PDF copy has previously been emailed.

Please note that the executed subsurface exploration scope of work is considered preliminary. Additional test borings will be required to provide final recommendations. This work should be performed after the building locations within the site and building footprint(s) have been established.

It is considered imperative that the geotechnical engineer and/or their representative be present during earthwork operations, foundation and floor slab installations to observe the field conditions with respect to the design assumptions and specifications. Professional Service Industries Engineering, PLLC will not be held responsible for interpretations and field quality control observations made by others.

Should there be any questions, please do not hesitate to contact our office at (716) 694-8657. Professional Service Industries Engineering, PLLC would be pleased to continue providing geotechnical services throughout the implementation of the project, and we look forward to working with you and your organization on this and future projects.

Respectfully submitted,  
**PROFESSIONAL SERVICE INDUSTRIES ENGINEERING, PLLC**

Steven P. Pump  
Branch Manager

David B. Sabol, PE  
Vice President

Paul S. Hundley  
Principal Consultant





PRELIMINARY GEOTECHNICAL  
ENGINEERING SERVICES ADDENDUM REPORT

For the proposed

STUDENT HOUSING DEVELOPMENT  
SEVEN (7) PARCELS IN THE VICINITY OF 959 DRYDEN ROAD  
ITHACA, TOMPKINS COUNTY, NEW YORK 14850

Prepared for

Trinitas Ventures, LLC  
201 Main Street, Suite 1000  
Lafayette, IN 47901

Prepared by

Professional Service Industries  
Engineering, PLLC  
3784 Commerce Court, Suite 300  
North Tonawanda, New York 14120  
Telephone (716) 694-8657  
Fax (716) 694-8638

PSI PROJECT NO.: 0806962 – ADDENDUM

August 8, 2018



A handwritten signature in black ink that reads "Steven Pump".

---

Steven P. Pump  
Branch Manager

A handwritten signature in black ink that reads "Paul S. Hundley".

---

Paul S. Hundley  
Principal Consultant



---

David B. Sabol, P.E.  
Vice President



**TABLE OF CONTENTS**

**1 PROJECT INFORMATION ..... 1**

1.1 PROJECT AUTHORIZATION ..... 1

1.2 PROJECT DESCRIPTION..... 1

1.3 PURPOSE AND SCOPE OF WORK..... 2

    1.3.1 *Field Exploration* ..... 2

    1.3.2 *Laboratory Testing* ..... 3

**2 SITE AND SUBSURFACE CONDITIONS ..... 4**

2.1 SITE LOCATION AND DESCRIPTION..... 4

2.2 SUBSURFACE CONDITIONS ..... 6

    2.2.1 *Local Geology* ..... 6

    2.2.2 *Test Borings*..... 7

2.3 GROUNDWATER CONDITIONS ..... 8

**3 PRELIMINARY OBSERVATIONS AND EVALUATIONS .....10**

3.1 GEOTECHNICAL DISCUSSION .....10

3.2 SITE PREPARATION .....11

3.3 FILL MATERIAL AND PLACEMENT .....12

3.4 SOIL SLOPES .....14

3.5 PRELIMINARY FOUNDATION RECOMMENDATIONS – SHALLOW FOUNDATIONS .....14

3.6 SEISMIC DESIGN .....15

3.7 PRELIMINARY FLOOR SLAB RECOMMENDATIONS.....17

3.8 UTILITIES TRENCHING .....18

3.9 RETAINING WALL STRUCTURE DESIGN AND CONSTRUCTION (\*IF APPLICABLE) .....19

3.10 RETAINING WALL BACK-DRAIN (\*IF APPLICABLE).....20

3.11 BELOW-GRADE WALL BACKFILL AND COMPACTION (\*IF APPLICABLE) .....21

3.12 SILTATION CONTROL .....22

3.13 PAVEMENT DESIGN .....22

    3.13.1 *Drainage of Pavement Structures* .....22

    3.13.2 *Pavement Design* .....23

    3.13.3 *Flexible Pavement Section* .....24

    3.13.4 *Rigid Concrete Pavement* .....25

    3.13.5 *Civil Design Considerations Pavements* .....26

**4 CONSTRUCTION CONSIDERATIONS.....27**

4.1 GROUNDWATER CONTROL.....27

4.2 SUBGRADE PREPARATION .....27

**5 EXCAVATIONS.....28**

**6 RECOMMENDATIONS FOR FINAL SUBSURFACE EXPLORATION.....29**

**7 CONSTRUCTION OBSERVATION AND TESTING .....30**

**8 GEOTECHNICAL RISK.....31**

**9 REPORT LIMITATIONS.....32**

FIGURE 1: SITE LOCATION PLAN

FIGURE 2: BORING LOCATION PLAN

**APPENDIX A**

BORING LOGS

GENERAL NOTES

UNIFIED SOIL CLASSIFICATION SYSTEM



## 1 PROJECT INFORMATION

### 1.1 PROJECT AUTHORIZATION

Professional Service Industries Engineering, PLLC (PSIE, PLLC) has completed a preliminary geotechnical engineering exploration for the proposed Student Housing Development project located at on seven (7) parcels of land in the vicinity of 959 Dryden Road in Ithaca, Tompkins County, New York. Written authorization to proceed with this geotechnical engineering evaluation and analysis was provided by Ms. Kimberly Hansen, Manager, Design & Development of Trinitas Ventures, LLC in the form of a signed copy of PSI Proposal No. 0806-237428 by Ms. Kimberly Hansen on March 6, 2018. Professional Service Industries Engineering, PLLC's services for this project were performed in accordance with PSI Proposal No. 0806-237428, dated March 5, 2018 and 0806-237428 – Rev. 1, dated June 18, 2018.

### 1.2 PROJECT DESCRIPTION

Project information was obtained from Mr. Damian VanMatre, Vice President with Trinitas Ventures, LLC. The following drawings were provided to develop the scope of work:

- One (1) Trinitas Ventures, LLC project drawing un-dated, un-numbered, and titled "The Project" containing the approximate property boundaries and the locations of the existing on-site and surrounding structures.

Based on the information provided, it is understood that the project is going to consist of the construction of one-hundred ninety-five (195) new two-story cottage and three-story townhome structures having a concrete slab-on-grade floor system to be located on seven (7) parcels of land in the vicinity of 959 Dryden Road in Ithaca, Tompkins County, New York. It is unknown if the structures will be steel and/or wood frame with block walls or masonry bearing wall construction. Asphaltic concrete parking and drive areas and Portland cement concrete sidewalks are also planned.

Structural loadings and grade changes were not provided. Therefore, this report is based upon wall loadings of three (3) kips per lineal foot, column loads, if any, of seventy-five (75) kips. The floor slab design is based on a maximum floor load of one hundred fifty (150) psf.

At this time, specific building locations, the proposed Finished Floor Elevations (FFE), and final grading plans were not provided. Therefore, this preliminary report is based upon the proposed building(s) footprint(s) and parking area and drive area final grades relatively following the existing site topography. It is estimated that the proposed building(s) footprint(s) and parking lot and drive areas will require earthwork operations consisting of between two (2) and three (3) feet of cut and fill to achieve final grades after removal of the topsoil and/or surficial materials. If the final grading plans and proposed building locations are known, we request to be retained to review the grading plans and submit supplemental recommendations based on these plans, if appropriate.

Vehicle and pavement loadings are indicated to be automobile traffic only; however some truck traffic is expected to service the facility. Therefore, vehicle and pavement loadings and asphaltic concrete pavement criteria for this report are as follows:



Design Life (years):	20
Terminal Serviceability:	2.5
Reliability Level	85%
Initial Serviceability:	4.2
Standard Deviation for	
Flexible Pavement:	0.45
Rigid Pavement:	0.35

In addition, the report is based upon *light duty* pavement having an Equivalent Single Axle Loading of 7,500 ESALs and *heavy duty* pavement having an Equivalent Single Axle Loading of 75,000 ESALs, respectively.

The information presented in this section was used in our evaluation. Estimated loads and corresponding foundation sizes have a direct effect on the recommendations, including the type of foundation, the allowable bearing pressure, and the estimated settlement. In addition, estimated subgrade elevations and cut/fill amounts can have a direct effect on the provided recommendations. If any of the noted information has changed or additional information becomes available, PSIE, PLLC should be notified so that we may amend the recommendations presented in this report, if appropriate.

*Please note that the executed subsurface exploration scope of work is considered preliminary. Additional test borings will be required to provide final recommendations. This work should be performed after the building locations within the site and building footprint(s) have been established.*

### **1.3 PURPOSE AND SCOPE OF WORK**

#### **1.3.1 FIELD EXPLORATION**

The purpose of this preliminary study was to evaluate the subsurface conditions at the site and to develop preliminary geotechnical related foundation, slab-on-grade, pavement, and fill recommendations. Professional Service Industries Engineering, PLLC's scope of services included site reconnaissance of the project area, a review of geologic maps of the area, and drilling eighteen (18) test borings within the project area, performed in two (2) phases. Phase I of the field drilling consisted of using a truck mount drill rig to perform nine (9) test borings within the project area to boring termination and/or auger refusal depths ranging from twenty-one (21) to twenty-five (25) feet below the existing ground surface on March 28 and 29, and April 9, 2018. Phase II of the field drilling consisted of using a track mount drill rig (performed by NYEG Drilling, LLC) to perform nine (9) test borings within the project area to boring termination and/or auger refusal depths ranging from twenty-one (21) to twenty-seven (27) feet below the existing ground surface on July 16, 17, and 18, 2018. The split spoon sampling procedures used during this exploration are in basic accordance with ASTM Designation D-1586.

Professional Service Industries Engineering, PLLC selected the borings' positions and the borings' depths. The borings were located in the field by representatives of PSIE, PLLC by measuring distances from known reference points. Top-of-hole elevations were not determined or provided for this preliminary report. Following completion of the field services, the recovered soil samples were returned to PSIE, PLLC's office for review, evaluation, and laboratory testing. The results of PSIE PLLC's subsurface exploration and soil sample documentation and testing are presented herein together with geotechnical recommendations for site preparation and building foundation support.



As directed by the client, PSIE, PLLC did not provide any service to investigate or detect the presence of moisture, mold or other biological contaminants in or around any structure, or any service that was designed or intended to prevent or lower the risk of the occurrence of the amplification of the same. Client acknowledges that mold is ubiquitous to the environment with mold amplification occurring when building materials are impacted by moisture. Client further acknowledges that site conditions are outside of PSIE, PLLC's control, and that mold amplification will likely occur, or continue to occur, in the presence of moisture. As such, PSIE, PLLC cannot and shall not be held responsible for the occurrence or recurrence of mold amplification.

The scope of services also does not include an environmental assessment for determining the presence or absence of wetlands, or hazardous or toxic materials in the soil, bedrock, surface water, groundwater, or air on or below, or around this site. Any statements in this report or on the boring logs regarding odors, colors, and unusual or suspicious items or conditions are strictly for informational purposes.

### **1.3.2 LABORATORY TESTING**

The samples obtained during the drilling operation were placed in sealed and labeled containers and transported to our North Tonawanda, New York laboratory. Representative soil samples were selected for laboratory testing to determine their index properties. The laboratory-testing program included: natural moisture content determination tests (ASTM D2216). The laboratory test results are presented further within the report. Laboratory testing was performed in general accordance with ASTM procedures. Unless otherwise informed, the soil samples will be discarded ninety (90) days from the issuance of the report.



## 2 SITE AND SUBSURFACE CONDITIONS

### 2.1 SITE LOCATION AND DESCRIPTION

The project site is located on seven (7) parcels of land in the vicinity of 959 Dryden Road in Ithaca, Tompkins County, New York. Primary access to the property is from either Dryden Road or Mt. Pleasant Road. The Boring Location Plan in the Appendix indicates the location of the seven (7) parcels of land with respect to Dryden Road and Mt. Pleasant Road.

Figure 1 – Site Location Map

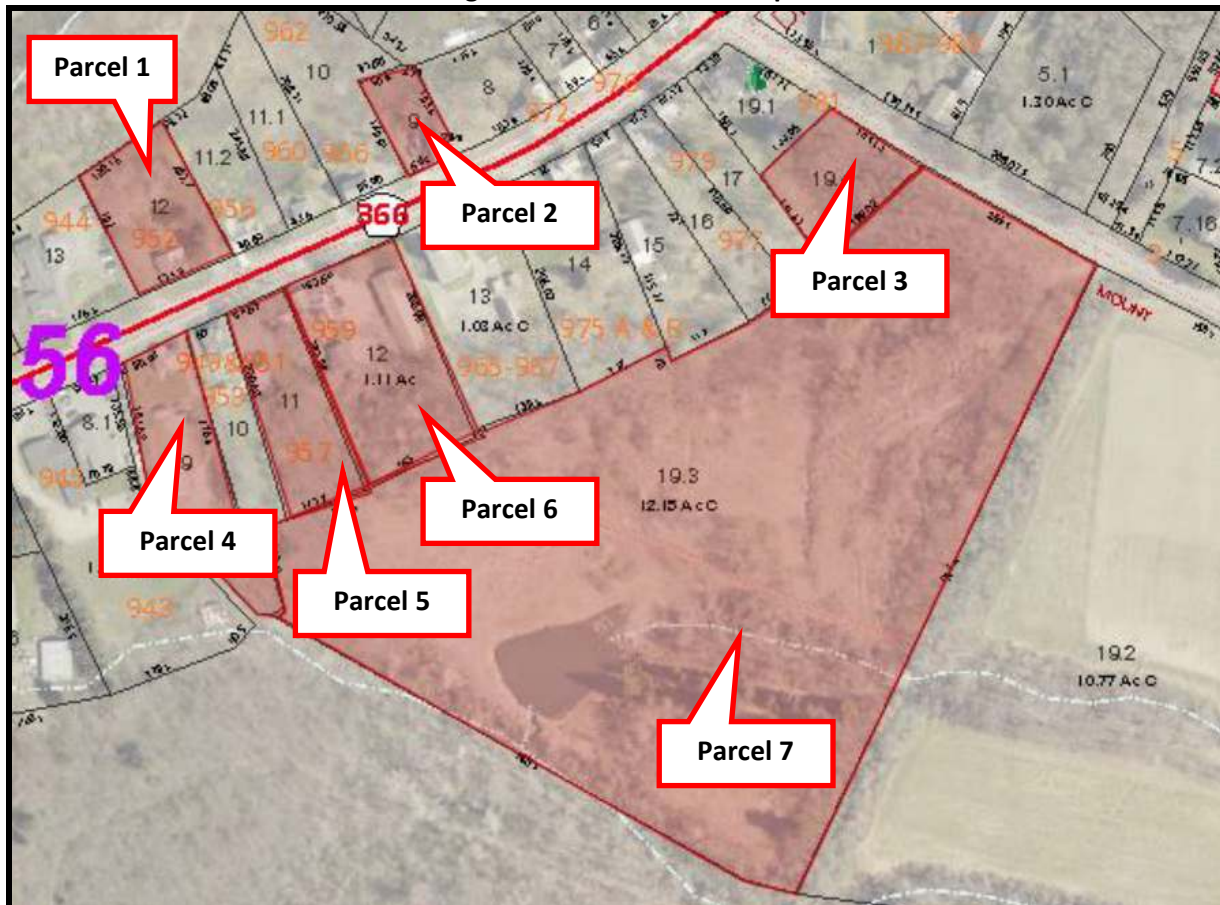

Image obtained from Bing Maps™

At the time of the drilling operations, the site PSIE, PLLC is designating as “Parcel 1” contained a two-story wood framed residential structure with an associated aggregate driveway. The remainder of the site was surficially covered in grass with scattered mature trees. Based on visual observations of the site by a PSIE, PLLC representative, it appears that the site slopes downward from northwest to southeast towards Dryden road approximately two (2) to three (3) feet. At the time of drilling operations and boring layout, no ponded water surfaces, drainage ditches, or catch basins were observed within the proposed project area. During the field operations, the truck-mounted drill rig experienced some difficulty accessing and traversing the site surface and boring locations due to the wet/loose/soft surficial soils due to recent rain events and/or snow melt.

At the time of the drilling operations, the site PSIE, PLLC is designating as “Parcel 2” contained a two-story wood framed residential structure with an associated aggregate driveway. The remainder of the





site was surficially covered in grass with dense brush cover and mature trees located to the rear or north side of the property. Based on visual observations of the site by a PSIE, PLLC representative, it appears that the site slopes downward from northwest to southeast towards Dryden road approximately two (2) to three (3) feet. At the time of drilling operations and boring layout, no ponded water surfaces, drainage ditches, or catch basins were observed within the proposed project area. During the field operations, the truck-mounted drill rig experienced difficulty accessing and traversing the site surface and boring locations due to the wet/loose/soft surficial soils due to recent rain events and/or snow melt.

At the time of the drilling operations, the site PSIE, PLLC is designating as "Parcel 3" was currently undeveloped and contained dense brush cover and mature trees. Based on visual observations of the site by a PSIE, PLLC representative, it appears that the site slopes downward from southeast to northwest approximately ten (10) to fifteen (15) feet. At the time of drilling operations and boring layout, no ponded water surfaces, drainage ditches, or catch basins were observed within the proposed project area. During the field operations, the truck-mounted drill rig experienced some difficulty accessing and traversing the site surface and boring locations due to the wet/loose/soft surficial soils due to recent rain events and/or snow melt.

At the time of the drilling operations, the site PSIE, PLLC is designating as "Parcel 4" contained three (3) two-story wood framed residential structures and a single-story garage structure, with an associated asphaltic concrete pavement driveway. The remainder of the site was surficially covered in grass along with medium dense brush cover and/or mature trees located along the west, east, and south property lines. Based on visual observations of the site by a PSIE, PLLC representative, it appears that the site slopes downward from south to north towards Dryden road approximately three (3) to four (4) feet. At the time of drilling operations and boring layout, no ponded water surfaces, drainage ditches, or catch basins were observed within the proposed project area. During the field operations, the truck-mounted drill rig experienced some difficulty accessing and traversing the site surface and boring locations due to the wet/loose/soft surficial soils due to recent rain events and/or snow melt.

At the time of the drilling operations, the site PSIE, PLLC is designating as "Parcel 5" contained a two-story wood framed residential structure with an associated aggregate driveway. The remainder of the site was surficially covered in grass with scattered mature trees. Based on visual observations of the site by a PSIE, PLLC representative, it appears that the site slopes downward from northwest to southeast towards Dryden road approximately three (3) to four (4) feet. At the time of drilling operations and boring layout, no ponded water surfaces, drainage ditches, or catch basins were observed within the proposed project area. During the field operations, the truck-mounted drill rig experienced some difficulty accessing and traversing the site surface and boring locations due to the wet/loose/soft surficial soils due to recent rain events and/or snow melt.

At the time of the drilling operations, the site PSIE, PLLC is designating as "Parcel 6" contained a single-story wood framed commercial structure with an associated aggregate driveway and parking areas. The remainder of the site was surficially covered in grass with dense brush cover and mature trees located to the rear or south side of the property. Based on visual observations of the site by a PSIE, PLLC representative, it appears that the site slopes downward from south to north towards Dryden road approximately four (4) to six (6) feet. At the time of drilling operations and boring layout, no ponded water surfaces, drainage ditches, or catch basins were observed within the proposed project area. During the field operations, the truck-mounted drill rig experienced some difficulty accessing and traversing the site surface and boring locations due to the wet/loose/soft surficial soils due to recent rain events and/or snow melt.



At the time of the drilling operations, the site PSIE, PLLC is designating as “Parcel 7” was currently undeveloped and contained medium dense to very brush cover and mature trees. Within the northeastern portion of the site near the access point off of Mt. Pleasant Road, various piles of fill and/or debris were observed. Please see Figure 2 for an example of the piles of fill and/or debris observed at the site. Based on visual observations of the site by a PSIE, PLLC representative, it appears that the site slopes downward from southeast to northwest approximately twenty (20) to fifty (50) feet. At the time of drilling operations and boring layout, no drainage ditches or catch basins were observed within the proposed project area. However, a pond was observed within the southwestern portion of the site. During the field operations, due to the wet/loose/soft surficial soils due to recent rain events and/or snow melt along with medium dense to dense brush cover, the truck mounted drill rig was not able to access some of the boring locations.

**Figure 2 – Various Piles of fill and/or Debris Located in the Northeastern portion of the Site.**



## **2.2 SUBSURFACE CONDITIONS**

### **2.2.1 LOCAL GEOLOGY**

The project site in Dryden, Tompkins County, New York area is located within the glaciated portion of the Finger Lakes physiographic province. As noted on the 1986 “Surficial Geologic Map of New York”, surface soils in the area generally consist of lacustrine silt and clay. Bedrock in the general site area is part of the Paleozoic, upper Devonian age, Genesee Group and Tully Limestone Group which consists of West River Shale, Genundewa Limestone, Penn Yan and Genesee Shales. Glacial imprints dominate the landscapes of central New York. Only small areas remain of the prior landforms that existed prior to the Pleistocene glaciation. Post-glacial processes have reshaped the flood plains and valley walls. In areas of steep slope, a cover of drift generally mantles the bedrock.





### **2.2.2 TEST BORINGS**

Professional Service Industries Engineering, PLLC performed a total of eighteen (18) test borings at the site. These borings were drilled on March 28 and 29, and April 9, 2018 for Phase I and July 16, 17, and 18, 2018 for Phase II. Professional Service Industries Engineering, PLLC selected the borings' positions and selected the borings' depths. The borings were located in the field by a representative of PSIE, PLLC by measuring distances from known reference points and located to avoid conflict with existing utilities. Professional Service Industries Engineering, PLLC notified Dig Safely New York for public utility clearance, prior to drilling the site.

The borings were advanced with hollow stem augers to boring termination and/or auger refusal depths ranging from twenty-one (21) to twenty-seven (27) feet below the existing ground surface. For each boring, Standard Penetration Tests (SPT's) were performed and split spoon samples were obtained at regular intervals to the boring termination depth. The split spoon sampling procedures used during this exploration are in basic accordance with ASTM Designation D-1586. The soil samples will be stored in our laboratory for further analysis, if requested. Unless notified otherwise, the samples will be disposed of after six (6) months.

The soil types encountered at the specific boring locations (see Boring Location Diagram) are presented in the form of individual soil profiles on the attached Boring Logs. The stratification presented is based on visual examination of the recovered soil samples and the interpretation of field logs by a geotechnical professional. Included on the profiles are the Standard Penetration Test values (N-values) for the borings. The N-values have been empirically correlated with various soil properties and are considered to be indicative of the relative density of cohesionless soils and the consistency of cohesive soils. A brief description of the soils encountered at this site is presented in this section.

The following subsurface description is of a generalized nature and intended to highlight the major subsurface stratification features and material characteristics. Professional Service Industries Engineering, PLLC was not provided with existing topographic information; therefore, ground surface elevations are not presented on the boring logs or referenced in this report. Professional Service Industries Engineering, PLLC recommends that the boring positions be established by a licensed surveyor. The Boring Logs illustrated in the Appendix should be reviewed for specific information at individual boring locations. These records include soil descriptions, stratifications, penetration resistances, locations of the samples and laboratory test data. The stratifications shown on the Boring Logs represent the conditions only at the actual boring locations. Variations may occur and should be expected between boring locations. The stratifications represent the approximate boundary between subsurface materials and the actual transition may be gradual.

**TOPSOIL:** At the ground surface at boring locations B-3, B-5, B-7, B-8, B-9, B-10, B-11, B-12, B-13, B-15, B-16, B-17, and B-18, topsoil having a thickness of ranging from approximately one (1) to six (6) inches was encountered. Please note that the actual amount of topsoil may vary widely between boring locations. *The contractor should determine the depth of topsoil to quantify topsoil depths for removal purposes.*

**AGGREGATE BASE FILL:** At the ground surface at boring locations B-4 and B-6, aggregate base fill was encountered. At these boring locations, the aggregate base fill ranged from approximately three (3) to six (6) inches in thickness. Please note that the actual amount of aggregate base fill may vary widely between boring locations.



UNDOCUMENTED FILL MATERIALS: At the surface at boring locations B-1, B-2, underlying the topsoil at boring locations B-5 and B-8, undocumented man placed fill materials consisting of silt/sand mixtures with gravel containing varying fractions of man-made materials such as organics, slag, and asphalt was encountered to approximate depths ranging from three and one-half (3-1/2) to eight (8) feet below existing site grades. Standard Penetration resistance (“N”-values) for the fill soils ranged from eight (8) to thirty-one (31) blows per foot. In natural soils, the “N”-values would indicate a loose to dense relative densities in granular soils. However, in miscellaneous fill, the “N”-values can be erratic, reflecting the variable composition of the fill material. The presence of obstruction and/or cobbles within fill can result in locally high “N”-values, even in a very loose condition. Other obstructions may be present in a miscellaneous uncontrolled fill, and may not be readily detectable with exploratory drill rig methods. Moisture contents of selected samples of the fill material ranged from five (5) to twenty-five (25) percent.

GRANULAR SOILS: At the surface at boring location B-14 and underlying the surface materials at all of the boring locations, granular soils of various textures extended to boring termination and/or auger refusal depths ranging from twenty-one (21) to twenty-seven (27) feet below existing grades. The granular soils were generally sampled as SILT (ML), CLAYEY SILT (ML), SANDY SILT (ML), SILTY SAND (SM), and/or POORLY GRADED SAND (SP). Standard Penetration resistance (“N”-values) ranged from eight (8) blows per foot to fifty (50) blows per two (2) inches, indicating loose to very dense relative densities. However, because of cobbles and boulders encountered in the soil profile, N-values in the granular soils may not be indicative of the actual relative density. Moisture contents of selected samples of the strata ranged from two (2) to twenty-seven (27) percent.

CLAYEY SOILS – Underlying the granular soils at boring locations B-10, B-11, B-12, B-17, and B-18, clayey soils consisting of SILTY CLAY (CL-ML) containing varying fractions of sand and gravel extended to an approximate depths ranging from six (6) to twenty-five (25) feet below existing site grades. The Standard Penetration resistance (“N”-values) for the clayey soils ranged from fifteen (15) to thirty-six (36) blows per foot, indicating stiff to hard consistencies. Based on penetrometer measurements of the clayey soils, which are an approximate measure of soil strength, the soil unconfined compressive strength of selected samples ranged from 1.5 to 3.5 tsf. Moisture content of selected samples from these clayey soils ranged from fourteen (14) to nineteen (19) percent.

### **2.3 GROUNDWATER CONDITIONS**

At the time of the site Phase I fieldwork on March 28 and 29 and April 9, 2018 and the Phase II fieldwork on July 16, 17, and 18, 2018, the following table illustrates the infiltrating groundwater levels encountered at the test boring locations prior to auger removal during the field drilling operations:



**Table 1 – Groundwater Levels (As Measured Beneath the Existing Site Grade)**

Boring Number	Phase of Drilling (I or II)	Groundwater Levels		Borehole Cave Depth (feet)
		During Drilling Activities	At Completion of Drilling Activities	
		(feet)	(feet)	
B-1	I	None	22.0	8.0
B-2	I	22.0	None	5.5
B-3	I	None	None	7.0
B-4	I	None	None	12.0
B-5	I	22.0	6.0	10.0
B-6	I	None	None	11.0
B-7	II	None	None	12.1
B-8	II	None	None	14.5
B-9	II	None	None	12.3
B-10	II	None	None	16.2
B-11	II	None	None	12.5
B-12	II	None	None	14.2
B-13	II	None	None	17.2
B-14	I	None	None	7.0
B-15	I	None	None	5.0
B-16	I	None	None	5.0
B-17	II	None	None	18.7
B-18	II	None	None	16.3

For safety purposes, all test borings were backfilled at the time of drilling completion.

These observations represent the groundwater conditions at the time of measurement and may not be indicative of other times. However, **discontinuous zones of perched water will exist within the shallower overburden materials** and the builder should anticipate surface and subsurface seepage into any subsurface excavations during high moisture periods of the year. Variations in groundwater levels should be expected seasonally, annually, and from location to location.



### 3 PRELIMINARY OBSERVATIONS AND EVALUATIONS

#### 3.1 GEOTECHNICAL DISCUSSION

The following preliminary geotechnical design recommendations have been developed on the basis of the previously described project characteristics and encountered subsurface conditions. If there are any changes in these project criteria, including building location on the site of final floor elevations, a review should be made by Professional Service Industries Engineering, PLLC to determine if modifications to the recommendations are necessary.

Once final design plans and specifications are available, a general review by Professional Service Industries Engineering, PLLC is recommended as a means to check that the evaluations made in preparation of this report are consistent with final construction plans and that earthwork and foundation recommendations are properly interpreted and implemented.

Based on the results of Professional Service Industries Engineering, PLLC's preliminary fieldwork, laboratory testing, and engineering analyses, the site appears suitable for the proposed structure and associated improvements provided the following recommendations are incorporated into the design and construction of the project. The primary geotechnical considerations for the development of this property will be the previous site development, the presence of old fill materials, the presence of cobbles and boulders, the potential thickness (height) of engineered fill materials, the moisture susceptibility of the on-site soils, and the wet/very loose surficial soils.

Due to the site development history, it must be recognized that subsurface conditions within the footprints of the proposed buildings may vary from conditions encountered at the boring locations.

Man-placed fill soils were observed in boring locations B-1, B-2, B-5, and B-8. A representative of the geotechnical engineer should verify the depth of fill at the time of construction. Based on the boring, the existing man-placed fill is considered suitable for support of foundations and floor slabs, provided proofroll/compaction acceptance utilizing a minimum fifteen (15) ton smooth drum vibratory roller operating in the vibratory mode.

The presence of cobbles and boulders encountered in the soils may present difficulty of their removal during trenching operations when utilizing standard backhoe type equipment; therefore, the utilization of large excavation equipment may be necessary.

Control points should be established within the anticipated fill areas (more than four [4] feet) to monitor, during and subsequent to the completion of the fill operations, any and all settlements of the final grade resulting from consolidation/compression of the area's subsurface materials under the weight of the engineered fill, and from the engineered fill under their own weight, if applicable. Settlement-time data, thus developed, should be employed to establish the time of placement of the building structures and pavement areas.

During the construction of soil slopes, whenever fill sectors meet the existing natural slopes and/or cut slopes, the structural fill is to be tied into the existing cut slopes by means of properly constructed benches or keys. Construction areas should be continuously benched over those areas where it is required as the work is brought up in layers. Bench/key construction should be of sufficient width to permit operation of placing and operation of compaction equipment. Each horizontal cut shall begin at the intersection of the original ground and the vertical sides of the previous cuts. Fill construction operation over the sloping sectors should be initiated from the toe and worked up the slope while cut operations should progress



downward from the top.

It must be recognized that soils that contain silt and clay are difficult to dry during wet or cool season. Careful attention to moisture content and compactive effort is important in dealing with such soils. The soils may need to be scarified and dried to a moisture content that will facilitate compaction in accordance with the structural fill requirements of this report. **Portland cement stabilization for silty soils (a fly ash / lime / kilndust for cohesive soils) may be necessary in order to expedite the work and achieve the required level of soil compaction.**

Depending on weather conditions and precipitation at the time of construction, the use of additional stabilization techniques such as choking the subgrade with coarse aggregate may be required in the upper twelve (12) to eighteen (18) inches of the exposed subgrade. Field conditions will dictate the extent of any undercuts.

With the previous mentioned considerations in mind, it is Professional Service Industries Engineering, PLLC's opinion that the proposed structures can be supported on shallow spread-type footings bearing on existing natural soils and/or compacted engineered fill. The building interior floors can be constructed on properly prepared subgrades following proofroll/proof-compaction acceptance of existing natural soil subgrade, qualified existing man-placed fill materials, and/or compacted engineered fill. The proposed pavement can be constructed on properly prepared subgrades following proofroll/compaction acceptance of natural soil subgrade, qualified existing man-placed fill materials, and/or compacted engineered fill.

*Please note that the executed subsurface exploration scope of work is considered preliminary. Additional test borings will be required to provide final recommendations. This work should be performed after the building locations within the site and building footprint(s) have been established.*

### **3.2 SITE PREPARATION**

Unless specifically indicated otherwise in the drawings and/or specifications, the limits of this subsurface preparation are considered to be that portion directly beneath and ten (10) feet beyond the building and appurtenances. Appurtenances are those items attached to the building and typically include, but are not limited to, the building sidewalks, porches, stoops, etc.

Site preparation should commence with the removal of the existing debris noted within the northeast portion of "Parcel 7" at the time of the drilling operations, any other debris/trash, existing foundations of existing on-site structures, floor slabs, walls, utilities, grass, topsoil, vegetation, any deleterious materials. The geotechnical engineer of record or his representative should determine the depth of removal at the time of construction. Underground storage tanks, abandoned utilities, old foundations or other features not evident at the time of Professional Service Industries Engineering, PLLC's investigation should also be removed. Professional Service Industries Engineering, PLLC recommends that all topsoil and loose and wet or deleterious soils in the construction areas be stripped from the site and either wasted or stockpiled for later use in landscaping. The geotechnical engineer of record or his representative should determine the depth of removal at the time of construction.

After removal of the existing debris/trash, any other debris/trash, existing old foundations, floor slabs, walls, utilities, grass, topsoil, vegetation, and loose and wet soils and other deleterious materials, the exposed undercut areas should be brought back up to proposed grades with compacted engineered fill. Prior to placement of the engineered fill, the geotechnical engineer of record or his representative



should observe the subgrade condition. Fill material and compaction requirements are discussed in more detail in the following paragraphs.

Professional Service Industries Engineering, PLLC has not been provided with any specific building locations and/or final grading plans and we do not know at this time how surface elevations will change at the time of construction. Additional site preparation will depend upon the proposed site grades and building features. Prior to the beginning of fill placement activities, PSIE, PLLC recommends that all areas receiving new fill be proof-compacted. Proof-compaction operations should be performed using a minimum fifteen (15) ton smooth drum vibratory roller, operating in the vibratory mode. Proof-compaction operations should be observed by the geotechnical engineer of record or his representative and should continue until a firm and unyielding condition exists (typically less than three-quarters inch ruts). Unstable soils which are revealed by proof-compaction and which cannot be adequately densified in place should be removed and replaced with crushed limestone (NYSDOT 304) or choked with coarse aggregate such as NYSDOT No. 4 stone under the recommendations of the geotechnical engineer of record or his representative. Field conditions will dictate the extent of any undercuts.

Proof-compaction operations should be observed by the geotechnical engineer of record or his representative and should continue until a firm and unyielding condition exists (typically less than three-quarters inch ruts). Unstable soils which are revealed by proof-compaction and which cannot be adequately densified in place should be removed and replaced with crushed limestone (NYSDOT 304) and/or choked with coarse aggregate such as NYSDOT No. 4 stone under the recommendations of the geotechnical engineer of record or his representative. Additionally, depending on weather conditions and precipitation at the time of construction, the use of additional stabilization techniques such as choking the subgrade with coarse aggregate may be required in the upper eighteen (18) to twenty-four (24) inches of the exposed subgrade. Field conditions will dictate the extent of any undercuts.

During the site area grading, zones of perched groundwater may be encountered. Local undercutting and pumping to remove water may be required when such zones are encountered, and provisions should be made in this regard by the builder.

After subgrade preparation and observation have been completed, fill placement may begin. The first layer of fill material should be placed in a relatively uniform horizontal lift and be adequately keyed into the stripped subgrade soils.

During site preparation, filled sidewalk vaults, burn pits, old foundations, trash pits or other isolated disposal areas may be encountered. All too frequently such buried material occurs in isolated areas outside boring locations. Any such material encountered during site work or foundation construction should be excavated and removed from the site.

### **3.3 FILL MATERIAL AND PLACEMENT**

After the performance of cutting to design subgrade, PSIE, PLLC recommends that proof-compaction operations should be performed using a 10 to 15-ton (static weight) smooth drum vibratory roller. Proof-compaction operations should be observed by a representative of PSIE, PLLC and should continue until a firm and unyielding condition exists (typically less than three-quarters inch ruts). Unstable soils which are revealed by proof-compaction and which cannot be adequately densified in-place should be removed and replaced with structural fill.



Excavations or depressions left from removal of trees should be backfilled with compacted structural fill. Subgrade areas should be kept properly drained and free of ponded water surfaces. This may be achieved by sloping the exposed pad so that storm water can flow off the pad.

Control points should be established within the anticipated fill areas (more than four [4] feet) to monitor, during and subsequent to the completion of the fill operations, any and all settlements of the final grade resulting from consolidation/compression of the area's subsurface materials under the weight of the engineered fill, and from the engineered fill under their own weight, if applicable. Settlement-time data, thus developed, should be employed to establish the time of placement of the building structure and pavement areas.

Based on the results of soil classifications, the existing surface soils at the boring locations B-1, B-2, and B-5, generally consist of existing granular fill. The on-site fill containing non-soil material such as slag is not suitable for reuse as structural fill material. The on-site soils at the remaining boring locations and the soils below the existing fill at boring locations B-1, B-2, and B-5 can be considered for reuse as structural fill, as long as the soils are placed within an acceptable moisture condition. It must be recognized that soils that contain silt and clay are difficult to dry during wet or cool season. Careful attention to moisture content and compactive effort are important in dealing with such soils and it is typical for wet or cool season grading operations to be hindered by the continual need to dry back silty and clayey soils during placement. It is advantageous to place a working course of compacted graded aggregate base over building and roadway areas between the time of initial grading and final floor slab construction. The graded aggregate base may need periodic replenishment depending on weather and traffic conditions during construction.

The on-site soils will be somewhat sensitive to moisture content variations. This general sensitivity to water will influence construction, since subgrade support capacities may deteriorate when this soil type becomes wet and/or disturbed. It is not unusual for wet or cool season grading operations to be hindered by the continual need to dry back the on-site natural soils during placement. If fill placement must proceed during other than the summer months, the use of imported granular fill with less than ten (10) percent passing the No. 200 sieve may be necessary.

On-site or imported structural fill materials should be free of organic or other deleterious materials. If grading results in a need for additional fill materials, the imported structural fill should have a maximum particle size less than three (3) inches, a modified Proctor maximum dry density greater than one hundred ten (110) pounds per cubic foot (pcf) and less than twenty (20) percent passing the No. 200 sieve. Structural fill should consist of non-expansive materials and not contain more than three (3) percent (by weight) of organic matter or other detrimental material. Typically, the Plasticity Index (PI) for the material should not exceed fifteen (15), and the Liquid Limit (LL) for the material should not exceed forty (40) (Unified Soil Classifications of GW, GM, GC, GP, SW, SM, SP, SC), unless otherwise allowed by the geotechnical engineer.

It must be recognized that soils that contain silt and clay are difficult to dry during wet or cool season. Careful attention to moisture content and compactive effort is important in dealing with such soils. The soils may need to be scarified and dried to a moisture content that will facilitate compaction in accordance with the structural fill requirements of this report. **Portland cement stabilization for silty soils (a fly ash/ lime / kilndust for cohesive soils) may be necessary in order to expedite the work and achieve the**





**required level of soil compaction.**

If the structural fill for the site is imported, the geotechnical engineer should test and report on the proposed imported fill prior to purchase and delivery. Based upon the topography and location of the site, imported fill will probably be required. Fine-grained soils and the on-site soils used for fill require close moisture content control to achieve the recommended degree of compaction and are not recommended for use during wet weather construction. Structural fill soils should be moisture conditioned to between two (2) percent below and two (2) percent above optimum moisture content and placed in maximum eight (8)-inch lifts in the excavation. Structural fill should be compacted to at least ninety-five (95) percent of the maximum density as determined by the Modified Proctor Test (ASTM D-1557). Each lift of compacted fill should be tested for density by a representative of the geotechnical engineer prior to placement of subsequent lifts. If fill placement must proceed during other than the summer months, the use of imported granular fill with less than ten (10) percent passing the No. 200 sieve may be necessary.

**3.4 SOIL SLOPES**

Based on our knowledge of shear strength characteristics of the encountered overburden soils, the following permanent construction slopes are recommended:

Silty Clays .....	2.5:1 (horizontal:vertical)
Silts.....	2.5:1 (horizontal:vertical)
Sands/Silty Sands.....	3:1 (horizontal:vertical)

If space limitations do not make it possible to achieve these configurations, reinforced earth structures and/or reinforced concrete retaining structures may need to be introduced at the toe of the slopes. The height of the retaining structures should be adjusted to achieve final slope configurations as recommended above. Also, the toe area of all sloping sectors should be graded in a manner such that the possibility of any water accumulation and coincidental softening of the toe support materials is precluded.

During the construction of soil slopes, whenever fill sectors meet the existing natural slopes and/or cut slopes, the structural fill is to be tied into the existing cut slopes by means of properly constructed benches or keys. Construction areas should be continuously benched over those areas where it is required as the work is brought up in layers. Bench/key construction should be of sufficient width to permit operation of placing and operation of compaction equipment. Each horizontal cut shall begin at the intersection of the original ground and the vertical sides of the previous cuts. Fill construction operation over the sloping sectors should be initiated from the toe and worked up the slope while cut operations should progress downward from the top.

**3.5 PRELIMINARY FOUNDATION RECOMMENDATIONS – SHALLOW FOUNDATIONS**

Based on the findings at the boring locations during our preliminary geotechnical exploration, it is PSIE, PLLC’s opinion that the proposed structures can be supported on shallow spread-type footings bearing on the existing natural soils and/or compacted engineered fill.

Shallow foundations consisting of conventional spread and strip footings should provide adequate support for the proposed construction. Allowable bearing pressures are expected to be **2,000 psf** when founded





on the existing soils and/or engineered fill. However, a final subsurface exploration will be required to provide final geotechnical recommendations once the building locations and footprints have been established.

For preliminary planning purposes, minimum lateral footing dimensions of about thirty (30) inches for column footings and twenty-four (24) inches for wall footings are recommended. Exterior foundations should be designed for a minimum embedment of forty-eight (48) inches below final exterior grades to provide adequate cover for frost protection. However, in areas where interior foundations are constructed in heated areas, the footings may be constructed at a minimum depth of eighteen (18) inches below final exterior grades. Wall footings should be provided with nominal, continuous, longitudinal steel reinforcement for greater bending strength so they can span across small areas of loose or soft soils that may go undetected during construction.

The foundation walls may not be free standing in the overburden soils; therefore the sides of the cut excavation for the footings may need to be sloped and the footings formed and backfilled in order to maintain a vertical concrete face.

Footing soils need to be observed and documented and concrete placed as quickly as possible to avoid exposure of the bottom of footing soils to disturbance due to construction traffic, drying or water accumulation. If concrete will not be placed the same day a foundation excavation is cut to grade, the contractor should be required to place three (3) to five (5) inches of compacted crushed aggregate or a concrete "mud mat" within the footing excavation. The foundation excavations should be observed by a representative of PSIE, PLLC prior to steel or concrete placement to document that the foundation materials are consistent with the report.

Once the footing concrete is placed, the foundations should be backfilled with structural fill as soon as it is safe to do so without causing damage to them. The backfill serves to protect the footing, is a component of overturning resistance and prevents accumulation of water around the foundations which can soften and weaken the bearing soils. The ground surface near the completed foundations should be sloped to drain away from the foundations throughout construction to avoid accumulation of moisture in the subgrade soils.

The foundation excavations should be observed by the geotechnical engineer of record or his representative prior to steel or concrete placement to document that the foundation materials are consistent with the report.

### **3.6 SEISMIC DESIGN**

The 2010 New York State Building Code is an adaptation/incorporates the 2015 International Building Code (IBC). As part of this code, the design of structures must consider dynamic forces resulting from seismic events. These forces are dependent upon the magnitude of the earthquake event as well as the properties of the soils that underlie the site.

Part of the IBC code procedure to evaluate seismic forces, requires the evaluation of the Seismic Site Class, which categorizes the site based upon the characteristics of the subsurface profile within the upper one hundred (100) feet BGS. To define the Seismic Site Class for this project, PSIE, PLLC has interpreted the results of the soil test borings drilled within the project site and estimated appropriate soil properties below the base of the borings to a depth of one (100) feet, as permitted by Section 1615.1.1 of the code. The estimated soil properties were based upon data available in published



regional geologic reports as well as Professional Service Industries Engineering, PLLC's experience with subsurface conditions in the general site area. Professional Service Industries Engineering, PLLC anticipates that the subsurface conditions below the explored depth may generally consist of dense to very dense granular soils overlying shale and/or limestone. Based on the review of the available data, knowledge of regional geology and the Standard Penetration Test (SPT) N values, we have assigned a **Soil Site Class D**, based on the preliminary borings performed, as defined in Section 1615.1.1. It must be noted that the value may be modified to "D" when the final geotechnical exploration is completed. The recommended seismic vales are presented in Table 2, Recommended Seismic Values.

The USGS-NEHRP probabilistic ground motion values for the site which were obtained from the USGS geohazards web page (<http://eqdesign.cr.usgs.gov/html/design-lookup.html>) and are as follows:

**Table 2 – Recommended Seismic Values**

Parameter	NY Building Code Reference	Value
Site Class	Table 1615.1.1	D
Mapped spectral accelerations for short periods ( $S_s$ )	Figure 1615(1)	0.126 g
Mapped spectral accelerations for a 1-second period ( $S_1$ )	Figure 1615(2)	0.056 g
Site coefficient $F_a$	Table 1615.1.2(1)	1.6
Site coefficient $F_v$	Table 1615.1.2(2)	2.4
Maximum considered earthquake spectral response for short periods ( $S_{MS}$ ) adjusted for site class effects	Equation 16-38	0.201 g
Maximum considered earthquake spectral response for 1-second period ( $S_{M1}$ ), adjusted for site class effects	Equation 16-39	0.136 g
Design Spectral Response acceleration at short periods ( $S_{DS}$ )	Equation 16-40	0.134 g
Design Spectral Response acceleration at 1-second periods ( $S_{D1}$ )	Equation 16-41	0.090 g

NOTES: \*Based upon a 2% Probability of Exceedence in 50 years  
 MCE = Maximum Considered Earthquake  
 g = acceleration due to gravity

The Site Coefficients,  $F_a$  and  $F_v$  presented in the above table were interpolated from IBC Tables 1613.5.3(1) and 1613.5.3(2) as a function of the site classification and mapped spectral response acceleration at the short ( $S_s$ ) and 1 second ( $S_1$ ) periods.

A **Seismic Design Category B** was assigned as determined for the intended building use (Occupancy Category II) and the IBC Tables 1613.5.6(1) and 1613.5.6(2). For the assigned Design Category, Section 1802 of the Code does not require an assessment of slope stability, liquefaction potential, and surface rupture due to faulting or lateral spreading. Detailed evaluations of these factors were beyond the scope of this study.



### 3.7 PRELIMINARY FLOOR SLAB RECOMMENDATIONS

Based upon the preliminary subsurface exploration, PSIE, PLLC anticipates that concrete slab for the proposed buildings can be ground-supported (slab on-grade) on natural soils, qualified existing man-placed fill materials, and/or compacted engineered fill placed over a natural soil subgrade, provided the upper soils have been proof-compacted with a minimum fifteen (15) ton smooth drum, vibratory roller, operating in the vibratory mode in order to confirm their suitability. Any observed soft/loose or otherwise unsuitable areas should be over-excavated down to firm subgrade and replaced with compacted engineered fill.

For the subgrade prepared as recommended and properly compacted fill, a modulus of subgrade reaction,  $k$  value, of 110 pounds per cubic inch (pci) may be used in the grade slab design based on a one (1) foot by one (1) foot plate load test. However, depending on how the slab load is applied, the value will have to be geometrically modified. The value should be adjusted for larger areas using the following expression for cohesionless soil:

$$\text{Modulus of Subgrade Reaction, } k_s = k \left( \frac{B+1}{2B} \right)^2 \text{ for cohesionless soil}$$

where:  $k_s$  = coefficient of vertical subgrade reaction for loaded area,  
 $k$  = coefficient of vertical subgrade reaction for 1 x 1 square foot area,  
 $B$  = width of area loaded, in feet.

In order to provide uniform subgrade reaction beneath any proposed floor slab-on-grade, we recommend that floor slabs be underlain by a minimum of six (6) inches of free-draining compactible, trimmable (a maximum particle size of three-quarters ( $\frac{3}{4}$ ) inch with less than five (5) percent material passing the no. 200 sieve), well-graded gravel or crushed rock base course. Base course material should be moisture conditioned to within +/- two (2) percent of optimum moisture content and compacted by mechanical means to a minimum of ninety-five (95) percent of the material's maximum dry density as determined in accordance with ASTM D 1557 (Modified Proctor).

The crushed stone should provide a capillary break to limit migration of moisture through the slab. If additional protection against moisture vapor is desired, a vapor retarding membrane may also be incorporated into the design. Factors such as cost, special considerations for construction, and the floor coverings suggest that the architect and owner make decisions on the use of vapor retarding membranes.

The precautions listed below should be followed for construction of slabs-on-grade pads. These details will not reduce the amount of movement, but are intended to reduce potential damage should some settlement of the supporting subgrade take place. Some increase in moisture content is inevitable because of development and associated landscaping. However, extreme moisture content increases can be largely controlled by proper and responsible site drainage, building maintenance and irrigation practices.

- Cracking of slabs-on-grade is normal and should be expected. Cracking can occur because of not only heaving or compression of the supporting soil and/or bedrock material, but also as a result of concrete curing stresses. The occurrence of concrete shrinkage cracks, and problems associated with concrete curing may be reduced and/or controlled by limiting the slump of the concrete, proper concrete placement, finishing, and curing, and by the placement of crack control joints at frequent intervals, particularly, where re-entrant slab corners occur. The American Concrete



Institute (ACI) recommends a maximum panel size (in feet) equal to approximately three times the thickness of the slab (in inches) in both directions. For example, joints are recommended at a maximum spacing of twelve (12) feet assuming a four-inch thick slab. Professional Service Industries Engineering, PLLC also recommends that the slab be independent of the foundation walls. Using fiber reinforcement in the concrete can also control shrinkage cracking.

- Areas supporting slabs should be properly moisture conditioned and compacted. Backfill in all interior and exterior water and sewer line trenches should be carefully compacted.
- Exterior slabs should be isolated from the building. These slabs should be reinforced to function as independent units. Movement of these slabs should not be transmitted to the building foundation or superstructure.

### **3.8 UTILITIES TRENCHING**

Excavation for utility trenches shall be performed in accordance with OSHA regulations as stated in 29 CFR Part 1926. It should be noted that utility trench excavations have the potential to degrade the properties of the adjacent fill materials. Utility trench walls that are allowed to move laterally can lead to reduced bearing capacity and increased settlement of adjacent structural elements and overlying slabs.

Backfill for utility trenches is as important as the original subgrade preparation or structural fill placed to support either a foundation or slab. Therefore, it is imperative that the backfill for utility trenches be placed to meet the project specifications for the structural fill of this project and/or any local municipal requirements for utility backfill. In areas that are not accessible to construction personnel and standard compaction equipment, PSIE, PLLC recommends that flowable fill or lean mix concrete be utilized for utility trench backfill. If on-site soils are placed as trench backfill, the backfill for the utility trenches should be placed in four (4) to six (6) inch loose lifts and compacted to a minimum of ninety-five (95) percent of the maximum dry density achieved by the modified Proctor test (ASTM D-1557).

The backfill soil should be moisture conditioned to be within two (2) of the optimum moisture content as determined by the modified Proctor test. Up to four (4) inches of bedding material placed directly under the pipes or conduits placed in the utility trench can be compacted to the ninety (90) percent compaction criteria with respect to the modified Proctor (ASTM D-1557). Compaction testing should be performed for every two hundred (200) cubic yards of backfill placed or each lift within two hundred (200) linear feet of trench, whichever is less. Backfill of utility trenches should not be performed with water standing in the trench. If granular material is used for the backfill of the utility trench, the granular material should have a gradation that will filter protect the backfill material from the adjacent soils.

If material having this gradation is not available, a geosynthetic non-woven filter fabric should be used to reduce the potential for the migration of fines into the backfill material. Granular backfill material shall be compacted to meet the above compaction criteria. The clean granular backfill material should be compacted to achieve a relative density greater than 75% or as specified by the geotechnical engineer for the specific material used.

Utility trenches should be connected to a suitably located outlet point with an invert elevation two (2) feet below the minimum elevation along the utility trenches. The purpose of this outlet is to allow removal of water which may accumulate in the six (6) inches of bedding material. The outlet points



should preferably discharge by gravity to the storm sewer system, but may discharge to sumps equipped with pumps if necessary.

### 3.9 RETAINING WALL STRUCTURE DESIGN AND CONSTRUCTION (\*IF APPLICABLE)

Below-grade retaining walls should be designed to resist lateral earth pressures. Lateral earth pressure is developed from the soils present within a wedge formed by the vertical below-grade wall and an imaginary line extending up and away from the bottom of the wall at an approximate 45° angle. The lateral earth pressures are determined by multiplying the vertical applied pressure by the appropriate lateral earth pressure coefficient K. If the walls are rigidly attached to the structure and not free to rotate or deflect at the top, PSIE, PLLC recommends designing the walls for the “at-rest” lateral earth pressure condition using  $K_o$ . Walls that are permitted to rotate and deflect at the top can be designed for the active lateral earth pressure condition using  $K_a$ . Passive pressure can be determined using  $K_p$ , with a factor of safety of 2.0. Recommended parameters for use in below grade walls are as follows:

**Table 3 – Soil Parameters and Lateral Earth Pressures**

Recommended Parameters for use in Retaining Wall Design				
Material Type	Angle of Internal Friction ( $\phi$ )			
1) Silty Sand (SM)	28°			
2) Silt (ML)	22°			
3) Poorly Graded Sand (SP)	32°			
4) Clean Crushed Limestone	35°			
Total Soil Density (pcf)	125			
Cohesion for Clay Soils (psf) (undrained, $\phi = 0$ )	500			
Groundwater Elevation	At bottom of the wall			
Parameters specific to soil type	1	2	3	4*
Friction Factor for Base	0.27	0.25	0.32	0.47
Coefficient of Active Pressure ( $K_a$ ) **	0.36	0.45	0.31	0.27
Coefficient of Passive Pressure ( $K_p$ ) **	2.77	2.20	3.24	3.69
Coefficient of At-Rest Pressure ( $K_o$ ) **	0.53	0.63	0.47	0.43

\* These values may be used for design only if the crushed limestone backfill extends back from the wall certain distances. These are a horizontal distance approximately equal to or greater than the total height of the wall at the surface, and at least one-foot beyond the heel of the wall footing.

\*\* Earth pressure coefficients valid for level backfill conditions with no surcharge.

The values presented above were calculated based on positive foundation drainage is provided to prevent the buildup of hydrostatic pressure. If surface loads are placed near the walls, such as traffic loads, they should be designed to resist an additional uniform lateral load of one-half of the vertical surface loads. An “equivalent fluid” pressure can be obtained from the above chart by multiplying the appropriate K-factor times the total unit weight of the soil. This applies to unsaturated conditions only. If a saturated “equivalent fluid” pressure is needed, the effective unit weight (total unit weight minus unit weight of water) should be multiplied times the appropriate K-factor and the unit weight of water added to that resultant. However, PSIE, PLLC does not recommend that earth retaining walls be designed with a hydrostatic load and that drainage should be provided to relieve the pressure.



The designs of retaining walls need to take into account the effects of geometry and loading conditions. The following charts have been included from NAVFAC 7.02 concerning slopes in the grade at the top of below grade wall. Depending on the geometry of the site, the lateral loading on the below grade wall should be modified according to these charts.

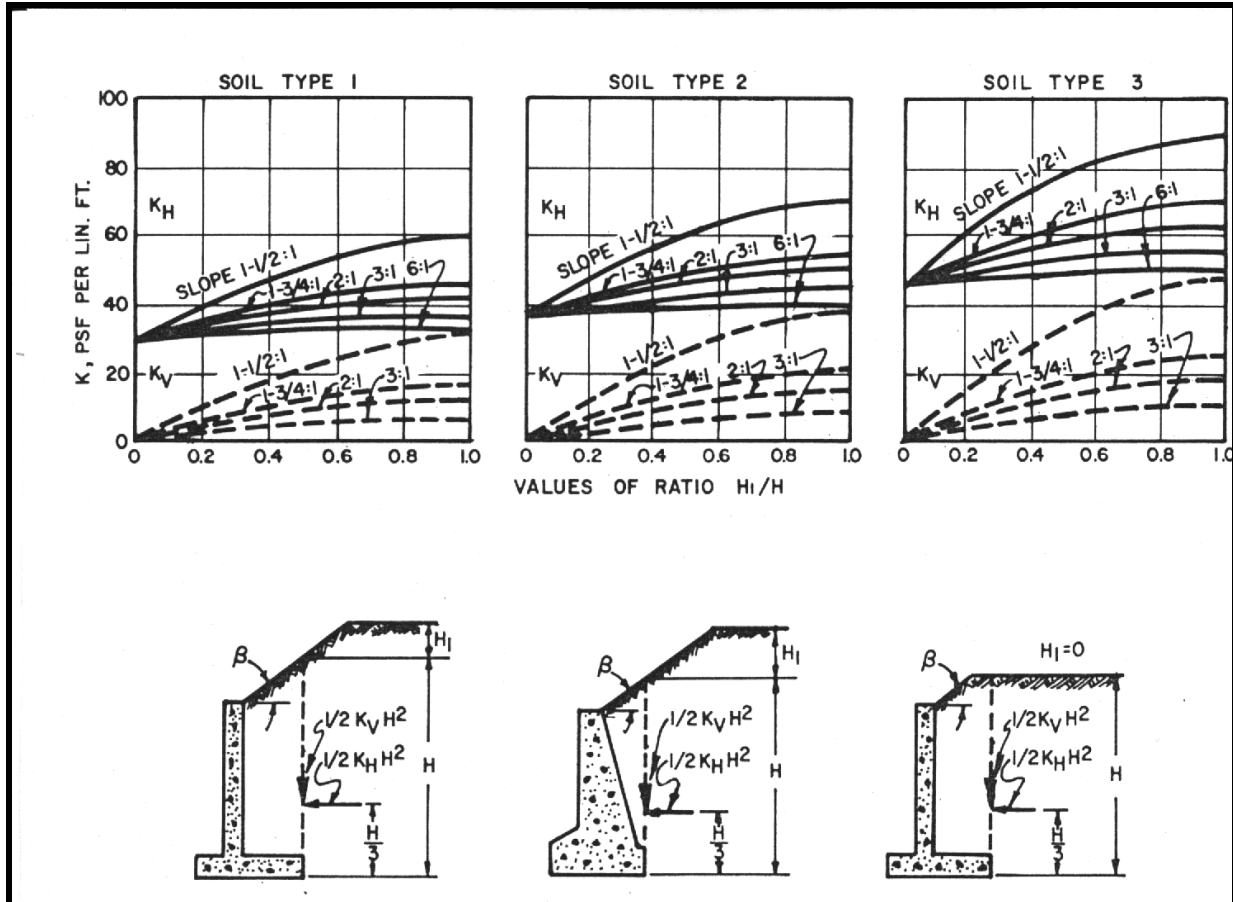

Soil Type 1 – Clean Sand and Gravel, GW, GP, SW, SP  
 Soil Type 2 – Dirty Sand and Gravel of Restricted Permeability, GM, GM-GP, SM-SP, SM  
 Soil Type 3 – Stiff Residual Silts and Clays, Silty Fine Sands, Clayey Sands and Gravels: CL, ML, CH, MH, SM, SC, GC

Special consideration must also be given to the stability of the natural cut ground when supporting substantial fills, to structural fills themselves, and to cut surfaces in natural soil. The evaluation of slope stability aspects of this site and the proposed development is beyond the scope of this exploration. A global slope stability evaluation should be performed by qualified geotechnical engineering personnel for the proposed retaining wall. The design of the walls for internal and external stability is typically the contractor/manufacturer's responsibility.

### 3.10 RETAINING WALL BACK-DRAIN (\*IF APPLICABLE)

Professional Service Industries Engineering, PLLC recommends that the retaining wall be adequately water-proofed and be provided with a wall back-drain system. One possible drainage system is shown in the sketch below and would include:

- 1) A four (4) or six (6) inch diameter perforated drain tile at the bottom of the backfill to collect seepage water with the tile connected to a suitable means of disposal.



- 2) Clean one-half ( $\frac{1}{2}$ ) inch or one (1) inch gravel classified as "GP" and containing less than five (5) percent passing a #200 sieve surrounding the drain-tile.
- 3) Non-woven four (4) ounce per square yard geotextile between the drainage material and the on-site soils to prevent infiltration of fine grained soils into the drain-tile, granular drainage blanket, or granular backfill.

The placement of a limited amount of granular material behind a retaining wall does not appreciably change the coefficient of lateral earth pressure acting on that wall. The lateral earth pressure acting on a below-grade structure is a function of the weight of the soil that exists above the theoretical plane projecting up from the base of the wall. The soil above this plane is held in place by two forces, the strength of the soil itself and the lateral resistance of the below-grade wall. Therefore, a thin layer of granular material behind the wall is of little consequence on the forces acting on the wall.

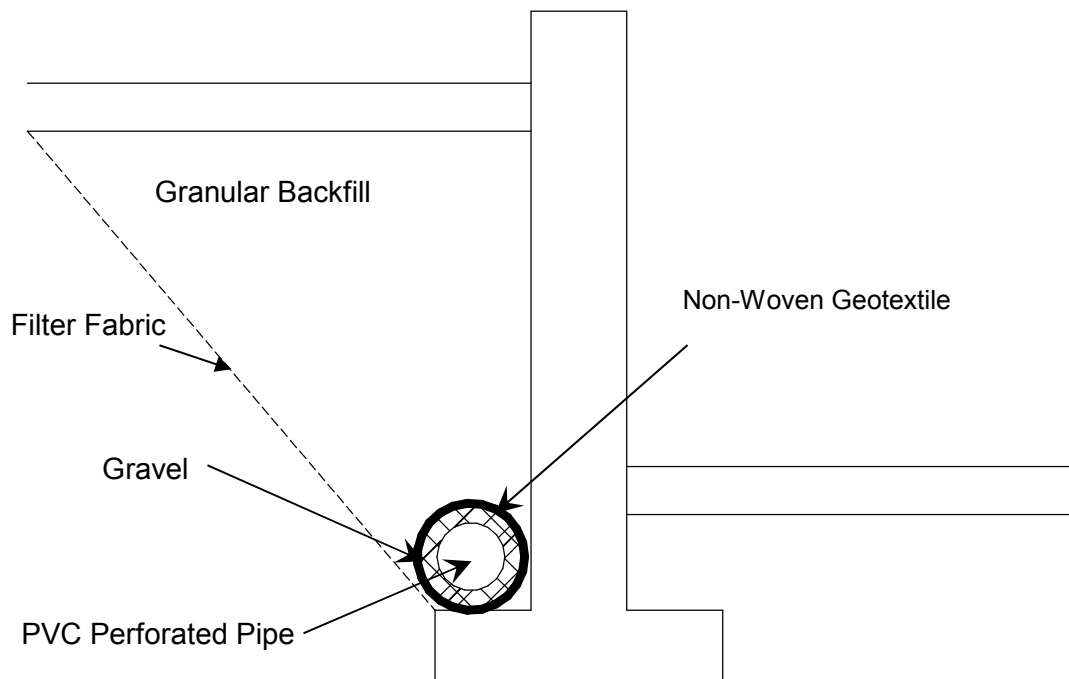

### 3.11 BELOW-GRADE WALL BACKFILL AND COMPACTION (\*IF APPLICABLE)

Professional Service Industries Engineering, PLLC suggests using granular material to provide improved drainage and to reduce lateral pressures on the walls resulting from water pressure. The backfill materials should be placed in lifts that do not exceed eight (8)-inches loose. The lift thickness may need to be reduced to thinner lifts immediately behind the walls to achieve the desired amount of compaction without overstressing the wall with the compaction process. Shale shall not be used for fill behind retaining walls.

Backfill should be placed in thin lifts and mechanically compacted to at least ninety-five (95) percent of the materials' maximum dry density and within two (2) percent of the optimum water content as determined by the modified Proctor test. Professional Service Industries Engineering, PLLC advises performing field density tests on the backfill to monitor compliance with the recommendations provided. Care should be exercised during the backfilling operation to prevent overstressing and damaging the walls.





### **3.12 SILTATION CONTROL**

The Clean Water Act, implemented in 1990 includes a federal permit program called the National Pollutant Discharge Elimination System (NPDES). This program requires that projects sites in excess of one (1) acre or are part of a development which exceeds one (1) acre be covered under a permit. This typically includes the development of a storm water pollution prevention plan (SWPPP) as well as period inspections (typically once a week plus after significant rainfall). Professional Service Industries Engineering, PLLC is available to assist with these services.

### **3.13 PAVEMENT DESIGN**

Based upon the preliminary completed geotechnical exploration, the existing subgrade soils and subbase material encountered at the soil boring locations are considered suitable for support of the proposed pavement provided the soils and subbase material have been proof-compacted with a minimum fifteen (15) ton smooth drum vibratory roller, operating in the vibratory mode making a minimum of four (4) passes, in order to confirm stability/suitability. However, additional soil borings will be required to confirm preliminary recommendations once final pavement areas have been established. Proof-compaction should also be performed immediately prior to the placement of any aggregate base stone. Unstable soils which are revealed by proof-compaction and which cannot be adequately densified in place should be removed and replaced with crushed limestone (NYSDOT 304) or similar material under the recommendations of the geotechnical engineer of record or his representative. Additionally, depending on weather conditions and precipitation at the time of construction, the use of additional stabilization techniques such as choking the subgrade with coarse aggregate may be required.

The following pavement recommendations are presented as preliminary for your consideration. The civil engineer for the project may have more traffic and project design data available than is presently known, and may wish to modify and refine these pavement sections. Professional Service Industries Engineering, PLLC will, upon request, be pleased to provide detailed pavement design recommendations when definite traffic and building plans are available. Note where streets are to be dedicated to the public jurisdiction, pavement sections should comply to local minimum standards.

Prior to placing the base or leveling course, the subgrade should be proof-compacted with a smooth steel drum vibratory roller weighing at least fifteen (15) tons and operating in the vibratory mode, in order to detect areas or pockets of unusually soft material. These areas, if encountered, should be over-excavated and replaced with crushed limestone (NYSDOT 304) or similar material under the recommendations of the geotechnical engineer of record or his representative.

Should the subgrade be wet and/or earthwork is anticipated during the wet seasons, a woven geotextile such as a Mirafi 500x (Grab Tear Strength, 200-300 lbs; Trapezoid Tear Strength, 75-120 lbs; Apparent Opening Size, US Sieve size 40 to 50 or 0.30 to 0.45 mm) or equivalent can be placed upon all the approved pavement subgrades prior to placing the subbase course materials.

#### **3.13.1 DRAINAGE OF PAVEMENT STRUCTURES**

Design for drainage is of the utmost importance to minimize detrimental effects that may shorten the service life of the pavements. Inclusion of adequate surface and subsurface drainage systems within the pavement areas is considered imperative in order to maintain the compacted subgrades as close to optimum moisture conditions as possible. The pavement should be crowned or sloped in order to promote effective surface drainage and reduce the risk of water ponding. We recommend a minimum





slope of one and one-half percent for the pavement surfaces. In addition, the subgrade should be similarly sloped to promote effective subgrade drainage. We recommend “stub” or “finger” drains be provided around catch basins, and in other low areas of the proposed pavements to limit the accumulation of water on the frost susceptible subgrade soils. Overall surface grades should be such that no pavement sectors are allowed to impound water. Surface water should be directed to a system of catch basins.

Subsurface drainage systems should be installed at least forty-two (42) inches below the design subgrade elevations at regular intervals including landscape areas, sidewalk areas and along the perimeter of the pavement areas. Subsurface drainage system consisting of perforated drain pipes bedded in and backfilled over with suitable filter materials (No. 57 coarse aggregate per AASHTO M-43) should be installed. The filter around the drainage members is to terminate in direct contact with the aggregate base course for the pavements. Also, all unpaved areas should be isolated from the paved sectors by including additional subsurface drainage lines following the above-outlined recommendations. Final grading plans should be reviewed to determine necessity and location of subsurface drains.

**3.13.2 PAVEMENT DESIGN**

AASHTO design methodology could be used to design the pavements. According to AASHTO design methodology, the pavement design thickness primarily depends on strength of the subgrade soils and type of traffic. Traffic includes several types of vehicles with various magnitudes of axle loads that may be subjected to the pavement during its service life. The design involves a traffic analyses that converts various types of vehicles with various magnitudes axle loads to a number of 18-kip equivalent single axle load repetitions.

Based on the anticipated traffic, the design engineer should perform the traffic analyses to compute the number of ESALs repetitions that would be subjected to the pavement during its service life or design life. Based on the computed ESALs, the pavements should be designed accordingly.

Based on previous experience, we have provided pavement thickness for both flexible pavement and rigid pavement systems in the tables below. The tables below include thickness design corresponding to two levels of traffic (light and heavy). The life expectancy in ESALs for each design is also presented. We recommend that the pavement design thicknesses correspond to low or medium traffic condition be used for parking areas. We recommend that the thickness design corresponding to high traffic condition be used for driveways, exit and entry lanes and frequently used areas. Where repeated high axle loading and heavy traffic is anticipated, such as the drive lanes and loading dock area for the over the road semi-tractor trailer trucks, rigid pavement is recommended or the equivalent flexible pavement ESAL design capacity be provided.

**Table 4 – Pavement Design Traffic**

Pavement Design Traffic	
Traffic Category	Design ESALS
Light Duty Section	7,500
Heavy Duty Section	75,000

In addition, specific design parameters considered in the pavement analysis are as follows:



**Table 5 – Pavement Analysis Specific Design Parameters**

CBR (Estimated)	3.0
Modulus of subgrade Reaction, K	110 psi/in
Soil Resilient Modulus	4,118 psi
Reliability	85%
Deviation	0.45 Asphalt
Deviation	0.35 Rigid
Combined Standard Error (S <sub>0</sub> )	0.5
Initial Serviceability	4.2
Terminal Serviceability	2.0
Modulus of Rupture	650 psi
Load Transfer	3.2 Dowels or Keys
Drainage Coefficient	1.0
Layer Coefficients	0.44 Asphalt
	0.12 Crushed Aggregate Base

**3.13.3 FLEXIBLE PAVEMENT SECTION**

Based on a design California Bearing Ratio (CBR) value of three (3.0) for the subgrade soils, and design ESALs for the various traffic types, Table 6 presents required structural numbers and typical flexible pavement sections.

**Table 6 – Flexible Pavement Minimum Sections (20-Year Design Life)**

Pavement Materials	Recommended Pavement Thickness (inches)	
	Light Duty Section	Heavy Duty Section
Required Structural Number, SN	1.90	2.72
Asphalt Top Course 9.5 mm F2 HMA	1.5	1.5
Asphalt Binder Course 19 mm F9 HMA	2.0	2.5
Aggregate Base Course (NYSDOT 304 Type 2)	8.0	10.0

A light-duty section is recommended in typical parking areas where cars and lightly loaded trucks are anticipated. A heavy-duty pavement section should be utilized in paved areas where traffic flow is channelized.

The following materials are recommended for the previously mentioned asphalt pavement structure components:

- Asphaltic Concrete Top Course-NYSDOT Standard Specification, Item No. 402.127202 – 12.5 mm F2 Hot Mix Asphalt.
- Asphaltic Concrete Binder Course-NYSDOT Standard Specification, Item No. 402.197902 – 19 mm F9 Hot Mix Asphalt.
- Crushed Aggregate Base (Subbase) Course-NYSDOT Standard Specification, Item No. 304.12 – Crushed Aggregate Base, Type 2.



If the anticipated traffic exceeds these values, PSIE, PLLC should be informed so that a specific pavement design can be made for the project, or the site Civil Engineer can modify the design.

In general, pavement construction should be performed in accordance with the New York State Department of Transportation specifications unless otherwise noted.

Aggregate base course material should be moisture conditioned to within two (2) percent of optimum moisture content and compacted by mechanical means to a minimum of ninety-five (95) percent of the material's maximum dry density as determined in accordance with ASTM D 1557 (Modified Proctor). Fill materials should be placed in layers that, when compacted, do not exceed about eight (8) inches. The granular base course should be built at least two (2) feet wider than the pavement on each side to support the tracks of the slipform paver. This extra width is structurally beneficial for wheel loads applied at pavement edge. The asphaltic concrete material should be compacted to at least ninety-two (92) percent of the material's theoretical maximum density as determined in accordance ASTM D 2041 (Rice Specific Gravity).

Periodic maintenance of the pavement should be anticipated. This should include sealing of cracks and joints and by maintaining proper surface drainage to avoid ponding of water on or near the pavement area.

**3.13.4 RIGID CONCRETE PAVEMENT**

Rigid concrete pavement is recommended where trash dumpsters are to be parked on the pavement or where a considerable load is transferred from relatively small steel wheels and for semi-tractor trailer traffic. This should provide better distribution of surface loads to subgrade without causing deformation of the surface.

Professional Service Industries Engineering, PLLC recommends that concrete pavement be designed for a modulus of subgrade reaction of 110 pci. A typical concrete pavement section would be:

**Table 7 – Typical Rigid Pavement Section**

<b>Rigid (Concrete) Pavement</b>	<b>Light-Duty</b>	<b>Heavy-Duty</b>
Portland Cement Concrete (4,000 psi)	5 inches	8 inches
Aggregate Base Course (NYSDOT 304 Type 2) NYSDOT Item 304.11 or 304.12	6 inches	6 inches

The following materials are recommended for the previously mentioned rigid pavement structure components:

- Portland Cement Concrete Slabs - 4,000 psi minimum compressive strength and the Portland Cement Concrete meeting the requirements of NYSDOT Standard Specifications 501.
- Crushed Aggregate Base (Subbase) Course-NYSDOT Standard Specification, Item No. 304.12 M – Crushed Aggregate Base, Type 2.



### **3.13.5 CIVIL DESIGN CONSIDERATIONS PAVEMENTS**

Related civil design factors such as drainage, cross-sectional configurations, surface elevations and environmental factors that will significantly affect the service life of the pavement must be included in the preparation of the construction drawings and specifications. Concrete pavement slabs should be provided with adequate steel reinforcement. Proper finishing of concrete pavements requires the use of sawed and sealed joints, which should be designed in accordance with current Portland Cement Association guidelines. Joint spacing intervals for plain concrete shall be in accordance with PCA guidelines according to pavement thickness. Dowel bars should be used to transfer loads at the transverse joints. Normal periodic maintenance will be required.

Surface water infiltration to the pavement subgrade layers may soften the subgrade soils. Considering several factors in the pavement design can reduce surface infiltration. To summarize, the following are some of the factors that need to be emphasized in order to maintain proper drainage.

- 1) Appropriate slopes should be provided.
- 2) Joints should be properly sealed and maintained.
- 3) Side drains or sub drains along a pavement section may be provided.
- 4) Proper pavement maintenance programs such as sealing surface cracks, and immediate repair of distressed pavement areas should be adopted.
- 5) During and after the construction, site grading should be kept in such a way that the water drains freely off the site and off any prepared or unprepared subgrade soils. Excavations should not be kept open for a long period of time.



## **4 CONSTRUCTION CONSIDERATIONS**

### **4.1 GROUNDWATER CONTROL**

Water should not be allowed to collect near or below the foundation or floor slab areas of the building either during or after construction. Undercut or excavated areas should be sloped toward one corner to facilitate removal of any collected rainwater, groundwater or surface runoff. Positive site drainage should be provided at all times to reduce infiltration of surface water around the perimeter of the building and beneath the floor slabs. All grades should be sloped away from the building and surface drainage should be collected and discharged such that water is not permitted to infiltrate the backfill of the building. It is anticipated that foundation excavations and construction control of water may be accomplished with pumps pumping from properly filtered open sumps.

Proper perimeter drainage mechanisms should be provided along all exterior foundation members. The elevation of the drainage lines should be adjusted to keep water a minimum of two (2) feet below the design subgrade elevation. A free flowing granular drainage fill such as crushed stone is to be employed around all drainage lines with the granular drainage fill encased in a geotextile filter fabric. The perimeter drains should discharge to a storm sewer or drainage ditch by gravity.

### **4.2 SUBGRADE PREPARATION**

The near surface soils present at this site are somewhat sensitive to softening due to rainfall and traffic. It is our experience that damp or wet soils tend to rut under rubber tire vehicle traffic. Maintenance of entrance roads and other areas subjected to construction traffic, such as floor slab areas, is typically required until floor slab construction is completed. If near surface soils become wet and disturbed, excavation and replacement with suitable compacted fill will be necessary. For this site during wet or cool seasons, it is advantageous to place a working course of compacted graded aggregate base over building and road way areas between the time of initial grading and final floor slab construction. The graded aggregate base may need periodic replenishment depending on weather and traffic conditions during construction.

Professional Service Industries Engineering, PLLC recommends that immediately prior to placement of stone and the beginning of floor slab construction, a representative of the Geotechnical Engineer evaluate the floor slab subgrades. If low density or otherwise unsuitable soils are encountered which cannot be adequately densified in place, such soils should be removed and replaced with well-compacted fill material placed in accordance with a previous section of this report or with well-compacted crushed stone materials.



## 5 EXCAVATIONS

In Federal Register, Volume 54, No. 209 (October, 1989), the United States Department of Labor, Occupational Safety and Health Administration (OSHA) amended its "Construction Standards for Excavations, 29 CFR, Part 1926, Subpart P". This document was established to ensure the safety of workers entering trenches or excavations.

Federal regulation mandates that all excavations, whether they be utility trenches, basement or footing excavations or others (i.e. underground storage tanks), be constructed in accordance with the OSHA requirements. It is our understanding that these regulations are being strictly enforced and if they are not closely followed, the owner and the contractor could risk injury to workers and be liable for substantial financial penalties.

The contractor is solely responsible for designing and constructing stable, temporary excavations and should shore, slope, or bench the sides of the excavations as required to maintain stability of both the excavation sides and bottom. The contractor's responsible person, as defined in "29 CFR Part 1926", should evaluate the soil exposed in the excavations as part of the contractor's safety procedures. In no case should slope height, slope inclination, or excavation depth, including utility trench excavation depth, exceed those specified in local, state, and federal safety regulations.

We are providing this information solely as a service to our client. Professional Service Industries Engineering, PLLC is not assuming responsibility for construction site safety or the contractor's activities; such responsibility is not being implied and should not be inferred.



## **6 RECOMMENDATIONS FOR FINAL SUBSURFACE EXPLORATION**

The final subsurface exploration will depend on the final footprint locations and the anticipated loads. Based upon the current preliminary site plans, Professional Service Industries Engineering, PLLC recommends additional borings within the proposed building footprints and parking/drive areas, once the building locations and parking/drive areas have been finalized within the proposed sites.



## **7 CONSTRUCTION OBSERVATION AND TESTING**

Professional Service Industries Engineering, PLLC should be retained to examine and identify soil exposures created during project excavations in order to verify that soil conditions are as anticipated. Professional Service Industries Engineering, PLLC further recommends that compacted engineered fill be continuously observed and tested during placement by our representative in order to document the compaction effort. Samples of fill materials should be submitted to Professional Service Industries Engineering, PLLC's laboratory for testing prior to placement of fills on site and should include a moisture-density relationship (Proctor) and sieve analysis including a minus 200 sieve test. Density testing should be performed at a rate of one per 2,500 square feet per six (6)-inch lift in building areas, one test per 10,000-square feet per six (6)-inch lift in pavement areas and one per one hundred linear feet per six (6)-inch lift in utility trench backfill.

Professional Service Industries Engineering, PLLC should also be retained to provide observation and testing of construction activities involved in the foundation, earthwork, and related vertical construction activities of this project. Professional Service Industries Engineering, PLLC cannot accept any responsibility for any conditions that deviated from those described in this report, nor for the performance of the foundation, if not engaged to also provide construction observation and testing for this project.

Costs for the recommended observations during construction are beyond the scope of this current consultation. Such future services would be at an additional charge.





## 8 GEOTECHNICAL RISK

The concept of risk is an important aspect of the geotechnical evaluation. The primary reason for this is that the analytical methods used to develop geotechnical recommendations do not comprise an exact science. Site exploration identifies actual subsurface conditions only at those points where samples are taken. A geotechnical report is based on conditions that existed at the time of the subsurface exploration. The analytical tools which geotechnical engineers use are generally empirical and must be used in conjunction with engineering judgment and experience. Therefore, the solutions and recommendations presented in the geotechnical evaluation should not be considered risk-free and, more importantly, are not a guarantee that the interaction between the soils and the proposed structure will perform as planned. The engineering recommendations presented in the preceding sections constitute Professional Service Industries Engineering, PLLC's professional estimate of those measures that are necessary for the proposed structure to perform according to the proposed design based on the information generated and referenced during this evaluation, and Professional Service Industries Engineering, PLLC's experience in working with these conditions.



## 9 REPORT LIMITATIONS

Professional Service Industries Engineering, PLLC's professional services have been performed, our findings obtained, and our recommendations prepared in accordance with generally accepted geotechnical engineering principles and practices. Professional Service Industries Engineering, PLLC is not responsible for the conclusions, opinions or recommendations made by others based on these data. No other warranties are implied or expressed.

The scope of investigation was intended to evaluate soil conditions within the influence of the proposed foundations. The analyses and recommendations submitted in this report are based upon the data obtained from the soil borings performed at the locations indicated. If any subsoil variations become evident during the course of this project, a re-evaluation of the recommendations contained in this report will be necessary after we have had an opportunity to observe the characteristics of the conditions encountered. The applicability of the report should also be reviewed in the event significant changes occur in the design, nature or location of the proposed structure.

The scope of our services does not include any environmental assessment or investigation for the presence or absence of hazardous or toxic materials in the soil, groundwater, or surface water within or beyond the site studied. Any statements in this report regarding odors, staining of soils, or other unusual conditions observed are strictly for the information of our client.

Professional Service Industries Engineering, PLLC did not provide any service to investigate or detect the presence of moisture, mold or other biological contaminate in or around any structure, or any service that was designed or intended to prevent or lower the risk of the occurrence of the amplification of the same. Mold is ubiquitous to the environment with mold amplification occurring when building materials are impacted by moisture. Site conditions are outside of Professional Service Industries Engineering, PLLC's control, and mold amplification will likely occur, or continue to occur, in the presence of moisture. As such, Professional Service Industries Engineering, PLLC cannot and shall not be held responsible of the occurrence or recurrence of mold amplification.

This report has been prepared for the exclusive use of Trinitas Ventures, LLC and their intermediaries, consultants for the specific application to this project at this site. Professional Service Industries Engineering, PLLC warrants that the evaluations and recommendations contained in this report are based on generally accepted professional engineering practices in the field of geotechnical engineering in the local area at the time of this report. No other warranties are implied or expressed.

## **FIGURES**

**Figure 1: Site Location Plan**

**Figure 2: Boring Location Plan**

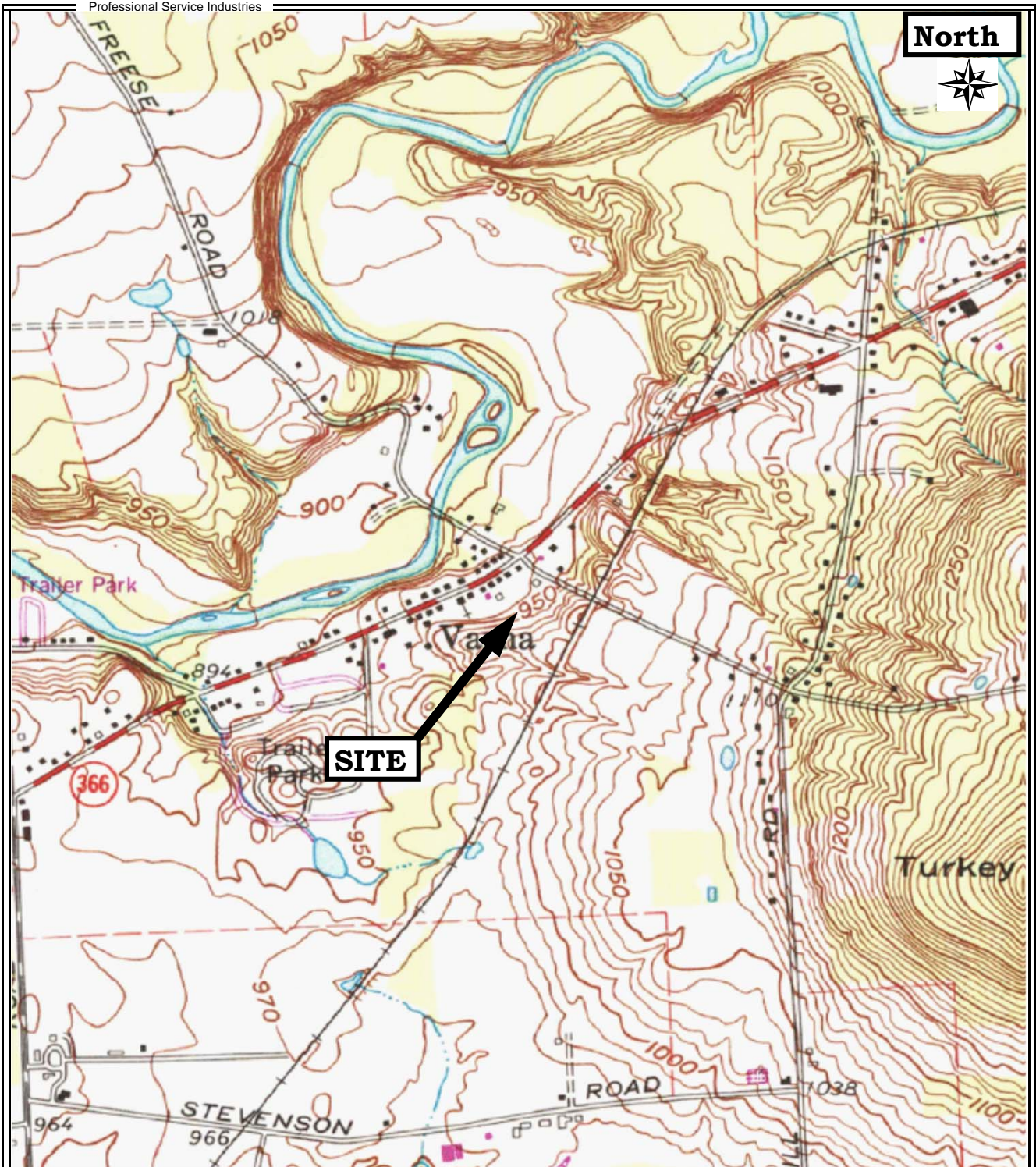

Base map provided by Microsoft Research Maps

Project Name:  
Proposed Student Housing Development  
Seven (7) Parcels in the vicinity of 959 Dryden Rd.  
Ithaca, Tompkins County, New York 14850

**General Site Location Plan**

Project No.: 0806962 - Addendum

Date: August 8, 2018



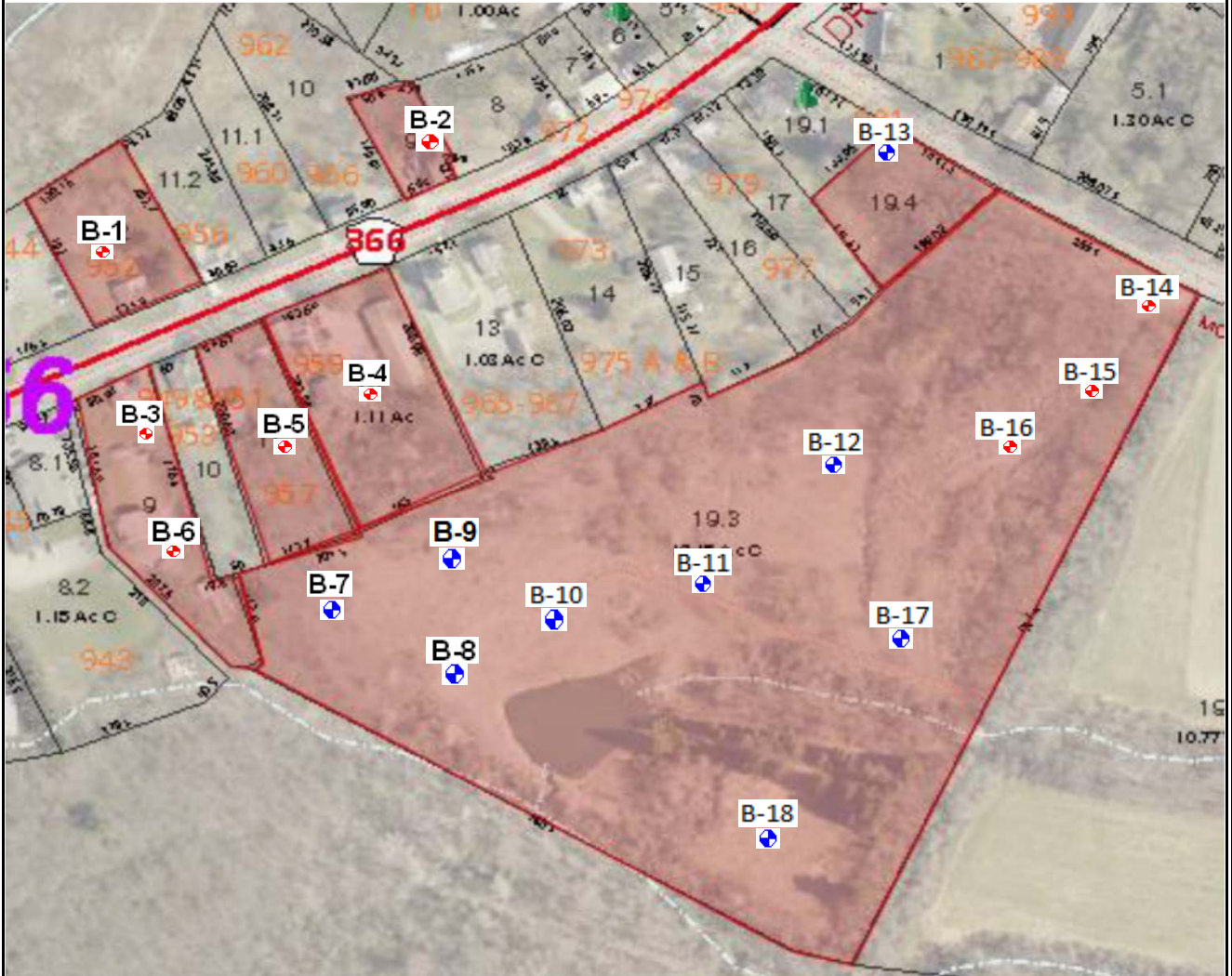

- ◻ - Soil Borings Performed During Phase I (March 28 & 29 and April 9, 2018)
- ◻ - Soil Borings Performed Durring Phase II (July 16, 17, 18, 2018)

NOT TO SCALE

Project Name:  
Proposed Student Housing Development  
Seven (7) Parcels in the vicinity of 959 Dryden Rd.  
Ithaca, Tompkins County, New York 14850

### Boring Location Plan

Project No.: 0806962 - Addendum

Date: August 8, 2018

## **APPENDIX A**

**Boring Logs**

**General Notes**

**Unified Soil Classification System**

**DATE STARTED:** 3/29/18 **DRILL COMPANY:** PSI, Inc.  
**DATE COMPLETED:** 3/29/18 **DRILLER:** Carl Rengert **LOGGED BY:** Steven Pump  
**COMPLETION DEPTH:** 25.0 ft **DRILL RIG:** CME 55  
**BENCHMARK:** N/A **DRILLING METHOD:** Hollow Stem Auger  
**ELEVATION:** N/A **SAMPLING METHOD:** 2-in SS  
**LATITUDE:** **HAMMER TYPE:** Automatic  
**LONGITUDE:** **EFFICIENCY:** 80%  
**STATION:** N/A **OFFSET:** N/A **REVIEWED BY:** DBS  
**REMARKS:** N<sub>60</sub> denotes the normalization to 60% efficiency as described in ASTM D4633. Hole Cave at 8'

# BORING B-1

<b>Water</b>	▽ While Drilling	None feet
	▼ Upon Completion	22 feet
	▽ Delay	N/A

**BORING LOCATION:**  
See Attached Boring Location Plan

Elevation (feet)	Depth (feet)	Graphic Log	Sample Type	Sample No.	Recovery (inches)	MATERIAL DESCRIPTION	USCS Classification	SPT Blows per 6-inch (SS)	Moisture, %	STRENGTH, tsf	Additional Remarks	
0				1	12	FILL, coarse to fine sand, little medium to fine gravel and silt, trace slag, brown, medium dense, moist	FILL	5-5-5 N <sub>60</sub> =13	8	×	○	
5				2	18	POORLY GRADED SAND (SP), medium to fine sand, some coarse to fine gravel, little silt, brown, dense, moist	SP	14-14-9 N <sub>60</sub> =31	10	×	○	
				3	12	SANDY SILT (ML), medium to fine sand, little clay and medium to fine gravel, brown, dense, moist	ML	13-14-13 N <sub>60</sub> =36	12	×	○	
10				4	5	** Cobbles noted		10-20-18 N <sub>60</sub> =51	7	×	>>○	
15				5	10	SILTY SAND (SM), medium to fine sand, some coarse to fine gravel, brown to gray, very dense, moist	SM	21-22-25 N <sub>60</sub> =63	7	×	>>○	
20				6	14	** Cobbles noted		28-23-27 N <sub>60</sub> =67	4	×	>>○	
25				7	18			31-30-18 N <sub>60</sub> =64	9	×	>>○	
						Boring Terminated at 25'						



Professional Service Industries, Inc.  
 3784 Commerce Court, Suite 300  
 North Tonawanda, NY 14120  
 Telephone: (716) 694-8657

**PROJECT NO.:** 0806962  
**PROJECT:** Proposed Student Housing Development  
**LOCATION:** Seven (7) Parcels of Land  
 959 Dryden Road  
 Ithaca, Tompkins County, NY 14850

**DATE STARTED:** 7/17/18 **DRILL COMPANY:** NYEG Drilling  
**DATE COMPLETED:** 7/17/18 **DRILLER:** Jesse Howe **LOGGED BY:** Steven Pump  
**COMPLETION DEPTH:** 27.0 ft **DRILL RIG:** CME 850  
**BENCHMARK:** N/A **DRILLING METHOD:** Hollow Stem Auger  
**ELEVATION:** N/A **SAMPLING METHOD:** 2-in SS  
**LATITUDE:** **HAMMER TYPE:** Automatic  
**LONGITUDE:** **EFFICIENCY:** N/A  
**STATION:** N/A **OFFSET:** N/A **REVIEWED BY:** DBS

# BORING B-10

<b>Water</b>	▽ While Drilling	None feet
	▼ Upon Completion	None feet
	▽ Delay	N/A

**BORING LOCATION:**  
See Attached Boring Location Plan

Elevation (feet)	Depth (feet)	Graphic Log	Sample Type	Sample No.	Recovery (inches)	MATERIAL DESCRIPTION	USCS Classification	SPT Blows per 6-inch (SS)	Moisture, %	STRENGTH, tsf	Additional Remarks
0						4" TOPSOIL					
				1	20	SANDY SILT (ML), fine sand, little medium to fine sand, trace clay, brown, medium dense, moist	ML	9-11-12-11 N=23	13		
				2	7	SILT (ML), little clay and fine sand, trace medium to fine gravel, brown, medium dense, moist	ML	10-8-7-8 N=15	15		
				3	0			12-10-11-12 N=21			
				4	17	CLAYEY SILT (ML), little fine sand, trace fine gravel, brown, medium dense, moist	ML	9-9-8-12 N=17	16		*
				5	4	SILTY CLAY (CL-ML), trace fine sand, brown, stiff, moist		8-8-7-8 N=15	18		
							CL-ML				
				6	20	SILTY SAND (SM), fine sand, trace clay, brown, medium dense, wet	SM	5-8-17-19 N=25	13		
				7	12	SILTY SAND (SM), medium to fine sand, little fine gravel, trace clay, brown and gray, very dense, moist	SM	27-25-32-28 N=57	7		>>⊙
				8	12	SANDY SILT (ML), fine sand, trace clay, gray, very dense, moist	ML	34-32-27-40 N=59	15		>>⊙
						Boring Terminated at 27'					



Professional Service Industries, Inc.  
 3784 Commerce Court, Suite 300  
 North Tonawanda, NY 14120  
 Telephone: (716) 694-8657

**PROJECT NO.:** 0806962  
**PROJECT:** Proposed Student Housing Development  
**LOCATION:** Seven (7) Parcels of Land  
 959 Dryden Road  
 Ithaca, Tompkins County, NY 14850



**DATE STARTED:** 7/18/18 **DRILL COMPANY:** NYEG Drilling  
**DATE COMPLETED:** 7/18/18 **DRILLER:** Jesse Howe **LOGGED BY:** Steven Pump  
**COMPLETION DEPTH:** 27.0 ft **DRILL RIG:** CME 850  
**BENCHMARK:** N/A **DRILLING METHOD:** Hollow Stem Auger  
**ELEVATION:** N/A **SAMPLING METHOD:** 2-in SS  
**LATITUDE:** **HAMMER TYPE:** Automatic  
**LONGITUDE:** **EFFICIENCY:** N/A  
**STATION:** N/A **OFFSET:** N/A **REVIEWED BY:** DBS

# BORING B-11

<b>Water</b>	▽ While Drilling	None feet
	▼ Upon Completion	None feet
	▽ Delay	N/A

**BORING LOCATION:**  
See Attached Boring Location Plan

Elevation (feet)	Depth (feet)	Graphic Log	Sample Type	Sample No.	Recovery (inches)	MATERIAL DESCRIPTION	USCS Classification	SPT Blows per 6-inch (SS)	Moisture, %	STRENGTH, tsf	Additional Remarks
0						4" TOPSOIL					
				1	10	SILT (ML), little medium to fine sand and fine gravel, trace clay, brown, medium dense, moist	ML	5-9-11-6 N=20	10	×	⊙
				2	14	CLAYEY SILT (ML), little fine sand, trace fine gravel, brown, medium dense, moist	ML	7-10-10-10 N=20	16	×	⊙
5				3	16			7-7-9-9 N=16	16	×	⊙
				4	14	CLAYEY SILT (ML), little fine sand, brown, medium dense, moist		8-7-8-9 N=15	17	×	⊙
				5	9			9-11-11-13 N=22	15	×	⊙
10							ML				
15				6	15	SILTY SAND (SM), medium to fine sand, some medium to fine gravel, brown, medium dense, moist	SM	12-18-11-13 N=29	11	×	⊙
20				7	3	SILTY CLAY (CL-ML), trace fine sand, gray, hard, moist	CL-ML	16-20-16-21 N=36	19	×	⊙
25				8	12	SILTY SAND (SM), fine sand, trace clay, gray, medium dense, moist	SM	14-12-14-18 N=26	19	×	⊙
						Boring Terminated at 27'					



Professional Service Industries, Inc.  
 3784 Commerce Court, Suite 300  
 North Tonawanda, NY 14120  
 Telephone: (716) 694-8657

**PROJECT NO.:** 0806962  
**PROJECT:** Proposed Student Housing Development  
**LOCATION:** Seven (7) Parcels of Land  
 959 Dryden Road  
 Ithaca, Tompkins County, NY 14850

**DATE STARTED:** 7/18/18 **DRILL COMPANY:** NYEG Drilling  
**DATE COMPLETED:** 7/18/18 **DRILLER:** Jesse Howe **LOGGED BY:** Steven Pump  
**COMPLETION DEPTH:** 27.0 ft **DRILL RIG:** CME 850  
**BENCHMARK:** N/A **DRILLING METHOD:** Hollow Stem Auger  
**ELEVATION:** N/A **SAMPLING METHOD:** 2-in SS  
**LATITUDE:** **HAMMER TYPE:** Automatic  
**LONGITUDE:** **EFFICIENCY:** N/A  
**STATION:** N/A **OFFSET:** N/A **REVIEWED BY:** DBS

# BORING B-12

<b>Water</b>	▽ While Drilling	None feet
	▼ Upon Completion	None feet
	▽ Delay	N/A

**BORING LOCATION:**  
See Attached Boring Location Plan

Elevation (feet)	Depth (feet)	Graphic Log	Sample Type	Sample No.	Recovery (inches)	MATERIAL DESCRIPTION	USCS Classification	SPT Blows per 6-inch (SS)	Moisture, %	STRENGTH, tsf	Additional Remarks
0		6" TOPSOIL									
	0			1	22	SANDY SILT (ML), medium to fine sand, little medium to fine gravel, trace clay, brown, medium dense, moist	ML	10-14-10-16 N=24	9	×	⊙
	2			2	10	POORLY GRADED SAND (SP), coarse to fine sand, some medium to fine gravel, little silt, brown, medium dense, moist	SP	7-9-11-11 N=20	6	×	⊙
	5			3	10	CLAYEY SILT (ML), little fine sand, trace fine gravel, brown, medium dense, moist	ML	5-5-10-8 N=15	16	×	⊙
	8			4	12	SILTY CLAY (CL-ML), trace fine sand, brown, very stiff, moist	CL-ML	6-12-10-15 N=22	19	×	⊙ *
	10			5	18	SILTY SAND (SM), medium to fine sand, little medium to fine gravel, trace clay, brown, very dense, moist	SM	17-29-27-31 N=56	10	×	⊙
	10					SANDY SILT (ML), medium to fine sand, some medium to fine gravel, trace clay, brown, very dense, moist	ML		8	×	⊙ >>
	15			6	14	SILTY SAND (SM), coarse to fine sand, some medium to fine gravel, brown, medium dense, moist	SM	14-14-11-14 N=25	9	×	⊙
	20			7	18	SILT (ML), little clay, trace fine sand, gray, medium dense, moist	ML	10-8-13-24 N=21	19	×	⊙
	25			8	14	CLAYEY SILT (ML), trace fine sand, gray, dense, moist	ML	14-16-19-21 N=35	19	×	⊙
						Boring Terminated at 27'					



Professional Service Industries, Inc.  
 3784 Commerce Court, Suite 300  
 North Tonawanda, NY 14120  
 Telephone: (716) 694-8657

**PROJECT NO.:** 0806962  
**PROJECT:** Proposed Student Housing Development  
**LOCATION:** Seven (7) Parcels of Land  
 959 Dryden Road  
 Ithaca, Tompkins County, NY 14850

DATE STARTED: 7/18/18  
 DATE COMPLETED: 7/18/18  
 COMPLETION DEPTH: 21.0 ft  
 BENCHMARK: N/A  
 ELEVATION: N/A  
 LATITUDE:  
 LONGITUDE:  
 STATION: N/A OFFSET: N/A  
 REMARKS: Hole Cave at 17.2'

DRILL COMPANY: NYEG Drilling  
 DRILLER: Jesse Howe LOGGED BY: Steven Pump  
 DRILL RIG: CME 850  
 DRILLING METHOD: Hollow Stem Auger  
 SAMPLING METHOD: 2-in SS  
 HAMMER TYPE: Automatic  
 EFFICIENCY: N/A  
 REVIEWED BY: DBS

<b>BORING B-13</b>		
<b>Water</b>	▽ While Drilling	None feet
	▼ Upon Completion	None feet
	▽ Delay	N/A

**BORING LOCATION:**  
 See Attached Boring Location Plan

Elevation (feet)	Depth (feet)	Graphic Log	Sample Type	Sample No.	Recovery (inches)	MATERIAL DESCRIPTION	USCS Classification	SPT Blows per 6-inch (SS)	Moisture, %	STANDARD PENETRATION TEST DATA		Additional Remarks
										N in blows/ft ⊙		
0						1" TOPSOIL						
				1	20	SILTY SAND (SM), coarse to fine sand, some medium to fine gravel, trace clay, brown, medium dense, moist	SM	11-11-11-11 N=22	9	×	⊙	
				2	17	SANDY SILT (ML), fine sand, little clay and fine gravel, brown, medium dense, moist	ML	8-9-11-13 N=20	12	×	⊙	
	5			3	21	POORLY GRADED SAND (SP), medium to fine sand, little silt, trace fine gravel, brown, medium dense, moist	SP	17-9-10-7 N=19	11	×	⊙	
				4	16	POORLY GRADED SAND (SP), medium to fine sand, little silt and medium to fine gravel, brown, medium dense, moist	SP	11-7-8-11 N=15	8	×	⊙	
	10			5	4	SILTY SAND (SM), fine sand, trace fine gravel and clay, gray, medium dense, moist	SM	12-12-11-14 N=23	13	×	⊙	
	15			6	16	SANDY SILT (ML), fine sand, trace clay, gray, dense, wet	ML	17-19-23-14 N=42	17		×	
	20			7	0	SEVERELY WEATHERED BEDROCK, trace coarse to fine sand, brown, very dense, moist			2	×		>>⊙
						Auger Refusal at 21'						



Professional Service Industries, Inc.  
 3784 Commerce Court, Suite 300  
 North Tonawanda, NY 14120  
 Telephone: (716) 694-8657

PROJECT NO.: 0806962  
 PROJECT: Proposed Student Housing Development  
 LOCATION: Seven (7) Parcels of Land  
 959 Dryden Road  
 Ithaca, Tompkins County, NY 14850

**DATE STARTED:** 3/28/18 **DRILL COMPANY:** PSI, Inc.  
**DATE COMPLETED:** 3/28/18 **DRILLER:** Carl Rengert **LOGGED BY:** Steven Pump  
**COMPLETION DEPTH:** 25.0 ft **DRILL RIG:** CME 55  
**BENCHMARK:** N/A **DRILLING METHOD:** Hollow Stem Auger  
**ELEVATION:** N/A **SAMPLING METHOD:** 2-in SS  
**LATITUDE:** **HAMMER TYPE:** Automatic  
**LONGITUDE:** **EFFICIENCY:** 80%  
**STATION:** N/A **OFFSET:** N/A **REVIEWED BY:** DBS

# BORING B-14

<b>Water</b>	▽ While Drilling	None feet
	▼ Upon Completion	None feet
	▽ Delay	N/A

**BORING LOCATION:**  
See Attached Boring Location Plan

**REMARKS:**  $N_{60}$  denotes the normalization to 60% efficiency as described in ASTM D4633. Hole Cave at 7'

Elevation (feet)	Depth (feet)	Graphic Log	Sample Type	Sample No.	Recovery (inches)	MATERIAL DESCRIPTION	USCS Classification	SPT Blows per 6-inch (SS)	Moisture, %	STRENGTH, tsf	Additional Remarks
0	0			1	12	SANDY SILT (ML), medium to fine sand, little medium to fine gravel, trace clay, brown, medium dense, moist  ** Cobbles noted	ML	7-8-8 $N_{60}=21$	13		
5	5			2	12	SILTY SAND (SM), medium to fine sand, trace fine gravel, brown, medium dense, wet	SM	3-3-5 $N_{60}=11$	21		
10	10			3	18	POORLY GRADED SAND (SP), fine sand, little silt, trace fine gravel, gray, medium dense, wet	SP	6-6-9 $N_{60}=20$	13		
15	15			4	18	SILTY SAND (SM), fine sand, gray, very dense, wet	SM	12-15-25 $N_{60}=53$	18		
20	20			5	18	SILTY SAND (SM), medium to fine sand, some medium to fine gravel, trace clay, gray, dense to very dense, moist  ** Cobbles noted	SM	12-13-15 $N_{60}=37$	14		
25	25			6	8		SM	26-50/3"	8		
25	25			7	6	POORLY GRADED SAND (SP), fine sand, trace silt, brown, very dense, moist  ** Cobbles noted	SP	30-50/6"	8		
Boring Terminated at 25'											

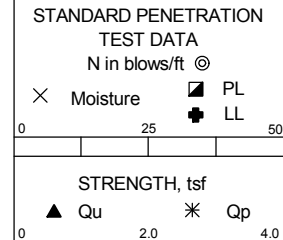

Professional Service Industries, Inc.  
3784 Commerce Court, Suite 300  
North Tonawanda, NY 14120  
Telephone: (716) 694-8657

**PROJECT NO.:** 0806962  
**PROJECT:** Proposed Student Housing Development  
**LOCATION:** Seven (7) Parcels of Land  
 959 Dryden Road  
 Ithaca, Tompkins County, NY 14850

**DATE STARTED:** 3/28/18 **DRILL COMPANY:** PSI, Inc.  
**DATE COMPLETED:** 3/28/18 **DRILLER:** Carl Rengert **LOGGED BY:** Steven Pump  
**COMPLETION DEPTH:** 25.0 ft **DRILL RIG:** CME 55  
**BENCHMARK:** N/A **DRILLING METHOD:** Hollow Stem Auger  
**ELEVATION:** N/A **SAMPLING METHOD:** 2-in SS  
**LATITUDE:** **HAMMER TYPE:** Automatic  
**LONGITUDE:** **EFFICIENCY:** 80%  
**STATION:** N/A **OFFSET:** N/A **REVIEWED BY:** DBS  
**REMARKS:**  $N_{60}$  denotes the normalization to 60% efficiency as described in ASTM D4633. Hole Cave at 5'

## BORING B-15

<b>Water</b>	▽ While Drilling	None feet
	▼ Upon Completion	None feet
	▽ Delay	N/A

**BORING LOCATION:**  
See Attached Boring Location Plan

Elevation (feet)	Depth (feet)	Graphic Log	Sample Type	Sample No.	Recovery (inches)	MATERIAL DESCRIPTION	USCS Classification	SPT Blows per 6-inch (SS)	STANDARD PENETRATION TEST DATA		Additional Remarks
									N in blows/ft ⊙	Moisture, %	
0						2" TOPSOIL					
				1	12	SANDY SILT (ML) medium to fine sand, little clay and fine gravel, brown, medium dense, moist	ML	4-6-8 $N_{60}=19$	12	⊙	
						** Cobbles noted					
	5			2	12	SILTY SAND (SM), medium to fine sand, trace clay and fine gravel, brown, medium dense to dense, moist		5-4-13 $N_{60}=23$	8	⊙	
						** Cobbles noted					
				3	18		SM	12-15-20 $N_{60}=47$	14	⊙	
	10			4	18	SANDY SILT (ML), fine sand, trace clay, brown, dense, moist	ML	12-14-17 $N_{60}=41$	25	⊙	
	15			5	18	SILTY SAND (SM), fine sand, trace clay, gray, dense, wet	SM	13-15-18 $N_{60}=44$	22	⊙	
	20			6	18	SILTY SAND (SM), medium to fine sand, little medium to fine gravel, trace clay, gray, very dense, moist	SM	11-17-27 $N_{60}=59$	8	⊙	>>
	25			7	18			25-40-31 $N_{60}=95$	9	⊙	>>
						Boring Terminated at 25'					



Professional Service Industries, Inc.  
 3784 Commerce Court, Suite 300  
 North Tonawanda, NY 14120  
 Telephone: (716) 694-8657

**PROJECT NO.:** 0806962  
**PROJECT:** Proposed Student Housing Development  
**LOCATION:** Seven (7) Parcels of Land  
 959 Dryden Road  
 Ithaca, Tompkins County, NY 14850

**DATE STARTED:** 3/28/18 **DRILL COMPANY:** PSI, Inc.  
**DATE COMPLETED:** 3/28/18 **DRILLER:** Carl Rengert **LOGGED BY:** Steven Pump  
**COMPLETION DEPTH:** 25.0 ft **DRILL RIG:** CME 55  
**BENCHMARK:** N/A **DRILLING METHOD:** Hollow Stem Auger  
**ELEVATION:** N/A **SAMPLING METHOD:** 2-in SS  
**LATITUDE:** **HAMMER TYPE:** Automatic  
**LONGITUDE:** **EFFICIENCY:** 80%  
**STATION:** N/A **OFFSET:** N/A **REVIEWED BY:** DBS

# BORING B-16

<b>Water</b>	▽ While Drilling	None feet
	▼ Upon Completion	None feet
	▽ Delay	N/A

**BORING LOCATION:**  
See Attached Boring Location Plan

**REMARKS:**  $N_{60}$  denotes the normalization to 60% efficiency as described in ASTM D4633. Hole Cave at 5'

Elevation (feet)	Depth (feet)	Graphic Log	Sample Type	Sample No.	Recovery (inches)	MATERIAL DESCRIPTION	USCS Classification	SPT Blows per 6-inch (SS)	Moisture, %	STRENGTH, tsf	Additional Remarks
0						2" TOPSOIL					
				1	12	CLAYEY SILT (ML), little fine sand, trace medium to fine gravel, brown, medium dense, moist	ML	4-6-9 $N_{60}=20$	22		
	5			2	12		ML	5-5-8 $N_{60}=17$	19		
				3	18	SILTY SAND (SM), medium to fine sand, little medium to fine gravel, trace clay, brown, dense, moist	SM	6-8-17 $N_{60}=33$	11		
	10			4	18	** Cobbles noted		9-14-18 $N_{60}=43$	10		
	15			5	18	SILTY SAND (SM), fine sand, trace fine gravel, gray, dense, wet	SM	10-13-19 $N_{60}=43$	21		
	20			6	12	SILTY SAND (SM), medium to fine sand, some medium to fine gravel, trace clay, gray, dense, moist	SM	20-15-16 $N_{60}=41$	8		
	25			7	18	SILTY SAND (SM), medium to fine sand, little clay and medium to fine gravel, gray, dense, moist	SM	16-17-16 $N_{60}=44$	7		
						Boring Terminated at 25'					



Professional Service Industries, Inc.  
 3784 Commerce Court, Suite 300  
 North Tonawanda, NY 14120  
 Telephone: (716) 694-8657

**PROJECT NO.:** 0806962  
**PROJECT:** Proposed Student Housing Development  
**LOCATION:** Seven (7) Parcels of Land  
 959 Dryden Road  
 Ithaca, Tompkins County, NY 14850

**DATE STARTED:** 7/18/18 **DRILL COMPANY:** NYEG Drilling  
**DATE COMPLETED:** 7/18/18 **DRILLER:** Jesse Howe **LOGGED BY:** Steven Pump  
**COMPLETION DEPTH:** 27.0 ft **DRILL RIG:** CME 850  
**BENCHMARK:** N/A **DRILLING METHOD:** Hollow Stem Auger  
**ELEVATION:** N/A **SAMPLING METHOD:** 2-in SS  
**LATITUDE:** **HAMMER TYPE:** Automatic  
**LONGITUDE:** **EFFICIENCY:** N/A  
**STATION:** N/A **OFFSET:** N/A **REVIEWED BY:** DBS

# BORING B-17

<b>Water</b>	▽ While Drilling	None feet
	▼ Upon Completion	None feet
	▽ Delay	N/A

**BORING LOCATION:**  
See Attached Boring Location Plan

Elevation (feet)	Depth (feet)	Graphic Log	Sample Type	Sample No.	Recovery (inches)	MATERIAL DESCRIPTION	USCS Classification	SPT Blows per 6-inch (SS)	Moisture, %	STRENGTH, tsf	Additional Remarks
0						4" TOPSOIL					
				1	14	CLAYEY SILT (ML), trace fine sand and fine gravel, brown, medium dense, moist	ML	4-5-6-7 N=11	22	⊗	
				2	11	CLAYEY SILT (ML), little fine sand, brown, medium dense, wet to moist	ML	7-7-9-10 N=16	21	⊗	
5				3	24			9-16-14-17 N=30	14	⊗	
				4	20	SANDY SILT (ML), medium to fine sand, little clay and medium to fine gravel, brown, dense, moist	ML	15-17-17-18 N=34	10	⊗	
				5	24	SILTY SAND (SM), medium to fine sand, little medium to fine gravel, trace clay, brown, very dense, moist	SM	20-20-34-32 N=54	11	⊗	>>
10											
15				6	6	SILTY CLAY (CL-ML), trace fine sand and fine gravel, brown, very stiff, moist	CL-ML	26-17-11-13 N=28	14	⊗	*
20				7	22			15-13-15-20 N=28	14	⊗	*
25				8	14	POORLY GRADED SAND (SP), fine sand, trace silt, gray, dense, wet	SP	11-21-28-47 N=49	14	⊗	
						Boring Terminated at 27'					



Professional Service Industries, Inc.  
 3784 Commerce Court, Suite 300  
 North Tonawanda, NY 14120  
 Telephone: (716) 694-8657

**PROJECT NO.:** 0806962  
**PROJECT:** Proposed Student Housing Development  
**LOCATION:** Seven (7) Parcels of Land  
 959 Dryden Road  
 Ithaca, Tompkins County, NY 14850



**DATE STARTED:** 7/18/18 **DRILL COMPANY:** NYEG Drilling  
**DATE COMPLETED:** 7/18/18 **DRILLER:** Jesse Howe **LOGGED BY:** Steven Pump  
**COMPLETION DEPTH:** 27.0 ft **DRILL RIG:** CME 850  
**BENCHMARK:** N/A **DRILLING METHOD:** Hollow Stem Auger  
**ELEVATION:** N/A **SAMPLING METHOD:** 2-in SS  
**LATITUDE:** **HAMMER TYPE:** Automatic  
**LONGITUDE:** **EFFICIENCY:** N/A  
**STATION:** N/A **OFFSET:** N/A **REVIEWED BY:** DBS

## BORING B-18

<b>Water</b>	▽ While Drilling	None feet
	▼ Upon Completion	None feet
	▽ Delay	N/A

**BORING LOCATION:**  
See Attached Boring Location Plan

Elevation (feet)	Depth (feet)	Graphic Log	Sample Type	Sample No.	Recovery (inches)	MATERIAL DESCRIPTION	USCS Classification	SPT Blows per 6-inch (SS)	Moisture, %	STRENGTH, tsf	Additional Remarks
0						3" TOPSOIL					
				1	10	CLAYEY SILT (ML), trace fine sand and fine gravel, brown, medium dense, moist	ML	6-6-5-7 N=11	18		
				2	14	SANDY SILT (ML), fine sand, trace clay, brown, medium dense, moist	ML	8-8-8-10 N=16	15		
	5			3	17	SILTY CLAY (CL-ML), little fine sand, trace fine gravel, brown, very stiff, moist	CL-ML	11-13-15-12 N=28	15		
				4	11	CLAYEY SILT (ML), little medium to fine sand and medium to fine gravel, brown, dense, moist	ML	17-17-15-21 N=32	22		
	10			5	24	SILTY SAND (SM), medium to fine sand, some medium to fine gravel, brown, dense, moist	SM	23-14-36-35 N=50	2		
	15			6	4	CLAYEY SILT (ML), trace medium to fine sand and fine gravel, brown, dense, wet	ML	17-22-21-23 N=43	24		
	20			7	20	POORLY GRADED SAND (SP), fine sand, little silt, trace clay, gray, dense, wet	SP	14-14-17-16 N=31	15		
	25			8	20	POORLY GRADED SAND (SP), fine sand, trace silt, gray, very dense, saturated	SP	21-23-31-30 N=54	16		
						Boring Terminated at 27'					



Professional Service Industries, Inc.  
 3784 Commerce Court, Suite 300  
 North Tonawanda, NY 14120  
 Telephone: (716) 694-8657

**PROJECT NO.:** 0806962  
**PROJECT:** Proposed Student Housing Development  
**LOCATION:** Seven (7) Parcels of Land  
 959 Dryden Road  
 Ithaca, Tompkins County, NY 14850



**DATE STARTED:** 3/29/18 **DRILL COMPANY:** PSI, Inc.  
**DATE COMPLETED:** 3/29/18 **DRILLER:** Carl Rengert **LOGGED BY:** Steven Pump  
**COMPLETION DEPTH:** 25.0 ft **DRILL RIG:** CME 55  
**BENCHMARK:** N/A **DRILLING METHOD:** Hollow Stem Auger  
**ELEVATION:** N/A **SAMPLING METHOD:** 2-in SS  
**LATITUDE:** **HAMMER TYPE:** Automatic  
**LONGITUDE:** **EFFICIENCY:** 80%  
**STATION:** N/A **OFFSET:** N/A **REVIEWED BY:** DBS

# BORING B-2

**Water**  
 ∇ While Drilling 22 feet  
 ▼ Upon Completion None feet  
 ▽ Delay N/A

**BORING LOCATION:**  
 See Attached Boring Location Plan

**REMARKS:**  $N_{60}$  denotes the normalization to 60% efficiency as described in ASTM D4633. Hole Cave at 5.5'

Elevation (feet)	Depth (feet)	Graphic Log	Sample Type	Sample No.	Recovery (inches)	MATERIAL DESCRIPTION	USCS Classification	SPT Blows per 6-inch (SS)	STANDARD PENETRATION TEST DATA		Additional Remarks
									N in blows/ft	Moisture, %	
0				1	12	FILL, silty sand, medium to fine sand, some medium to fine gravel, brown, medium dense, moist  ** Cobbles noted	FILL	8-7-8 $N_{60}=20$	5	×	○
5				2	18	FILL, coarse to fine sand, some medium to fine gravel, little silt, brown, medium dense, moist  ** Cobbles noted	FILL	9-9-12 $N_{60}=28$	5	×	○
				3	10	POORLY GRADED SAND (SP), coarse to fine sand, some coarse to fine gravel, little silt, brown, medium dense, moist  ** Cobbles noted	SP	12-12-9 $N_{60}=28$	6	×	○
10				4	14	POORLY GRADED SAND (SP), coarse to fine sand, some coarse to fine gravel, little silt, brown, dense, saturated  ** Cobbles noted	SP	12-14-18 $N_{60}=43$	12	×	○
15				5	18	SANDY SILT (ML), fine sand, trace clay, brown, dense, saturated	ML	8-13-17 $N_{60}=40$	20	×	○
20				6	18	SILTY SAND (SM), fine sand, trace clay, gray, dense, wet	SM	13-15-19 $N_{60}=45$	21	×	○
25				7	18		SM	12-18-19 $N_{60}=49$	22	×	○
						Boring Terminated at 25'					



Professional Service Industries, Inc.  
 3784 Commerce Court, Suite 300  
 North Tonawanda, NY 14120  
 Telephone: (716) 694-8657

**PROJECT NO.:** 0806962  
**PROJECT:** Proposed Student Housing Development  
**LOCATION:** Seven (7) Parcels of Land  
 959 Dryden Road  
 Ithaca, Tompkins County, NY 14850

**DATE STARTED:** 3/29/18 **DRILL COMPANY:** PSI, Inc.  
**DATE COMPLETED:** 3/29/18 **DRILLER:** Carl Rengert **LOGGED BY:** Steven Pump  
**COMPLETION DEPTH:** 21.0 ft **DRILL RIG:** CME 55  
**BENCHMARK:** N/A **DRILLING METHOD:** Hollow Stem Auger  
**ELEVATION:** N/A **SAMPLING METHOD:** 2-in SS  
**LATITUDE:** **HAMMER TYPE:** Automatic  
**LONGITUDE:** **EFFICIENCY:** 80%  
**STATION:** N/A **OFFSET:** N/A **REVIEWED BY:** DBS

# BORING B-3

<b>Water</b>	▽ While Drilling	None feet
	▼ Upon Completion	None feet
	▽ Delay	N/A

**BORING LOCATION:**  
See Attached Boring Location Plan

**REMARKS:** N<sub>60</sub> denotes the normalization to 60% efficiency as described in ASTM D4633. Hole Cave at 7'

Elevation (feet)	Depth (feet)	Graphic Log	Sample Type	Sample No.	Recovery (inches)	MATERIAL DESCRIPTION	USCS Classification	SPT Blows per 6-inch (SS)	Moisture, %	STRENGTH, tsf	Additional Remarks
0						1" TOPSOIL					
				1	12	CLAYEY SILT (ML), little medium to fine sand and medium to fine gravel, brown, medium dense, moist	ML	6-6-5 N <sub>60</sub> =15	9	×	⊙
	5			2	16	CLAYEY SILT (ML), little fine sand, trace organics, brown, loose, wet	ML	5-3-3 N <sub>60</sub> =8	27	⊙	×
				3	12	CLAYEY SILT (ML), little medium to fine sand, trace medium to fine gravel, brown, medium dense, wet	ML	4-4-4 N <sub>60</sub> =11	16	⊙	×
	10			4	12	POORLY GRADED SAND (SP), coarse to fine sand, some coarse to fine gravel, little silt, brown, medium dense, saturated  ** Cobbles noted	SP	6-5-7 N <sub>60</sub> =16	10	×	⊙
	15			5	18	SILTY SAND (SM), medium to fine sand, little to some medium to fine gravel, gray, very dense, moist  ** Cobbles noted ** Boulder Encountered at 17'	SM	16-30-50 N <sub>60</sub> =107	7	×	>>⊙
	20			6	5			50/4"	5	×	>>⊙
						Auger Refusal at 21'					



Professional Service Industries, Inc.  
 3784 Commerce Court, Suite 300  
 North Tonawanda, NY 14120  
 Telephone: (716) 694-8657

**PROJECT NO.:** 0806962  
**PROJECT:** Proposed Student Housing Development  
**LOCATION:** Seven (7) Parcels of Land  
 959 Dryden Road  
 Ithaca, Tompkins County, NY 14850

**DATE STARTED:** 3/28/18  
**DATE COMPLETED:** 3/28/18  
**COMPLETION DEPTH:** 25.0 ft  
**BENCHMARK:** N/A  
**ELEVATION:** N/A  
**LATITUDE:**  
**LONGITUDE:**  
**STATION:** N/A **OFFSET:** N/A  
**REMARKS:** N<sub>60</sub> denotes the normalization to 60% efficiency as described in ASTM D4633. Hole Cave at 12'

**DRILL COMPANY:** PSI, Inc.  
**DRILLER:** Carl Rengert **LOGGED BY:** Steven Pump  
**DRILL RIG:** CME 55  
**DRILLING METHOD:** Hollow Stem Auger  
**SAMPLING METHOD:** 2-in SS  
**HAMMER TYPE:** Automatic  
**EFFICIENCY:** 80%  
**REVIEWED BY:** DBS

# BORING B-4

<b>Water</b>	▽ While Drilling	None feet
	▼ Upon Completion	None feet
	▽ Delay	N/A

**BORING LOCATION:**  
See Attached Boring Location Plan

Elevation (feet)	Depth (feet)	Graphic Log	Sample Type	Sample No.	Recovery (inches)	MATERIAL DESCRIPTION	USCS Classification	SPT Blows per 6-inch (SS)	Moisture, %	STRENGTH, tsf	Additional Remarks
0				1	12	6" AGGREGATE FILL POORLY GRADED SAND (SP), medium to fine sand, little silt, trace fine gravel, brown, medium dense, moist	SP	8-7-5 N <sub>60</sub> =16	15		
				2	18	SILTY SAND (SM), fine sand, trace fine gravel and clay, brown, medium dense, moist ** Cobbles noted	SM	5-5-6 N <sub>60</sub> =15	15		
				3	18	SILTY SAND (SM), fine sand, little clay and medium to fine gravel, brown, medium dense, wet	SM	8-9-10 N <sub>60</sub> =25	14		
				4	18	SILTY SAND (SM), medium to fine sand, some medium to fine gravel, gray, very dense, moist ** Cobbles noted	SM	12-15-27 N <sub>60</sub> =56	8		
				5	7		SM	50/5"	3		
				6	22	SILTY SAND (SM), fine sand, trace clay, gray, very dense, moist	SM	40-48-50/5"	15		
				7	18	SILT (ML), little fine sand, gray, very dense, moist	ML	30-38-45 N <sub>60</sub> =111	15		
						Boring Terminated at 25'					



Professional Service Industries, Inc.  
 3784 Commerce Court, Suite 300  
 North Tonawanda, NY 14120  
 Telephone: (716) 694-8657

**PROJECT NO.:** 0806962  
**PROJECT:** Proposed Student Housing Development  
**LOCATION:** Seven (7) Parcels of Land  
 959 Dryden Road  
 Ithaca, Tompkins County, NY 14850

**DATE STARTED:** 4/9/18 **DRILL COMPANY:** PSI, Inc.  
**DATE COMPLETED:** 4/9/18 **DRILLER:** Carl Rengert **LOGGED BY:** Steven Pump  
**COMPLETION DEPTH:** 25.0 ft **DRILL RIG:** CME 55  
**BENCHMARK:** N/A **DRILLING METHOD:** Hollow Stem Auger  
**ELEVATION:** N/A **SAMPLING METHOD:** 2-in SS  
**LATITUDE:** **HAMMER TYPE:** Automatic  
**LONGITUDE:** **EFFICIENCY:** 80%  
**STATION:** N/A **OFFSET:** N/A **REVIEWED BY:** DBS

# BORING B-5

<b>Water</b>	▽ While Drilling	22 feet
	▼ Upon Completion	6 feet
	▽ Delay	N/A

**BORING LOCATION:**  
See Attached Boring Location Plan

**REMARKS:**  $N_{60}$  denotes the normalization to 60% efficiency as described in ASTM D4633. Hole Cave at 10'

Elevation (feet)	Depth (feet)	Graphic Log	Sample Type	Sample No.	Recovery (inches)	MATERIAL DESCRIPTION	USCS Classification	SPT Blows per 6-inch (SS)	STANDARD PENETRATION TEST DATA				Additional Remarks
									N in blows/ft ⊙		STRENGTH, tsf		
									Moisture, %	PL	LL		
									0 25 50	×	+		
										▲ Qu	* Qp		
									0 2.0 4.0				
0				1	12	3" TOPSOIL FILL, sandy silt, fine sand, trace fine gravel and slag, brown, loose, moist	FILL	2-2-4 $N_{60}=8$	25	⊙	×		
5				2	5	SILTY SAND (SM), medium to fine sand, some medium to fine gravel, brown and gray, medium dense, moist	SM	10-10-9 $N_{60}=25$	8	×	⊙		
				3	7	** Cobbles noted SILTY SAND (SM), coarse to fine sand, some coarse to fine gravel, trace clay, brown and gray, dense, saturated	SM	17-13-13 $N_{60}=35$	7	×	⊙		
10				4	17	** Cobbles noted POORLY GRADED SAND (SP), medium to fine sand, little silt and medium to fine gravel, trace clay, gray, dense to very dense, moist  ** Cobbles noted		13-15-19 $N_{60}=45$	7	×	⊙		
15				5	12		SP	21-50/5"	8	×		>>⊙	
20				6	12			15-50/4"	7	×		>>⊙	
25				7	12			30-50/5"	9	×		>>⊙	
						Boring Terminated at 25'							



Professional Service Industries, Inc.  
 3784 Commerce Court, Suite 300  
 North Tonawanda, NY 14120  
 Telephone: (716) 694-8657

**PROJECT NO.:** 0806962  
**PROJECT:** Proposed Student Housing Development  
**LOCATION:** Seven (7) Parcels of Land  
 959 Dryden Road  
 Ithaca, Tompkins County, NY 14850

**DATE STARTED:** 4/9/18 **DRILL COMPANY:** PSI, Inc.  
**DATE COMPLETED:** 4/9/18 **DRILLER:** Carl Rengert **LOGGED BY:** Steven Pump  
**COMPLETION DEPTH:** 23.0 ft **DRILL RIG:** CME 55  
**BENCHMARK:** N/A **DRILLING METHOD:** Hollow Stem Auger  
**ELEVATION:** N/A **SAMPLING METHOD:** 2-in SS  
**LATITUDE:** **HAMMER TYPE:** Automatic  
**LONGITUDE:** **EFFICIENCY:** 80%  
**STATION:** N/A **OFFSET:** N/A **REVIEWED BY:** DBS  
**REMARKS:** N<sub>60</sub> denotes the normalization to 60% efficiency as described in ASTM D4633. Hole Cave at 11'

## BORING B-6

<b>Water</b>	▽ While Drilling	None feet
	▼ Upon Completion	None feet
	▽ Delay	N/A

**BORING LOCATION:**  
See Attached Boring Location Plan

Elevation (feet)	Depth (feet)	Graphic Log	Sample Type	Sample No.	Recovery (inches)	MATERIAL DESCRIPTION	USCS Classification	SPT Blows per 6-inch (SS)	STANDARD PENETRATION TEST DATA		Additional Remarks
									N in blows/ft ⊙	Moisture, %	
0				1	18	3" AGGREGATE FILL					
				2	12	SILTY SAND (SM), medium to fine sand, little medium to fine gravel, trace clay, brown, medium dense to very dense, moist	SM	5-5-5 N <sub>60</sub> =13	12	⊙	
	5			3	18	** Cobbles noted		6-7-9 N <sub>60</sub> =21	11	⊙	
				4	16	SILTY SAND (SM), medium to fine sand, some medium to fine gravel, gray, very dense, moist		12-25-29 N <sub>60</sub> =72	11	⊙	>>⊙
	10			5	10	** Cobbles noted		16-20-27 N <sub>60</sub> =63	7	⊙	>>⊙
	15			6	5		SM	35-50/2"	6	⊙	>>⊙
	20							50/5"	2	⊙	>>⊙
						Auger Refusal at 23'					



Professional Service Industries, Inc.  
 3784 Commerce Court, Suite 300  
 North Tonawanda, NY 14120  
 Telephone: (716) 694-8657

**PROJECT NO.:** 0806962  
**PROJECT:** Proposed Student Housing Development  
**LOCATION:** Seven (7) Parcels of Land  
 959 Dryden Road  
 Ithaca, Tompkins County, NY 14850

**DATE STARTED:** 7/16/18 **DRILL COMPANY:** NYEG Drilling  
**DATE COMPLETED:** 7/16/18 **DRILLER:** Jesse Howe **LOGGED BY:** Steven Pump  
**COMPLETION DEPTH:** 27.0 ft **DRILL RIG:** CME 850  
**BENCHMARK:** N/A **DRILLING METHOD:** Hollow Stem Auger  
**ELEVATION:** N/A **SAMPLING METHOD:** 2-in SS  
**LATITUDE:** **HAMMER TYPE:** Automatic  
**LONGITUDE:** **EFFICIENCY:** N/A  
**STATION:** N/A **OFFSET:** N/A **REVIEWED BY:** DBS

# BORING B-7

<b>Water</b>	▽ While Drilling	None feet
	▼ Upon Completion	None feet
	▽ Delay	N/A

**BORING LOCATION:**  
See Attached Boring Location Plan

**REMARKS:** Hole Cave at 12.1'

Elevation (feet)	Depth (feet)	Graphic Log	Sample Type	Sample No.	Recovery (inches)	MATERIAL DESCRIPTION	USCS Classification	SPT Blows per 6-inch (SS)	STANDARD PENETRATION TEST DATA		Additional Remarks	
									N in blows/ft @			
0						6" TOPSOIL						
				1	14	SILT (ML), little medium to fine sand and fine gravel, trace clay, brown, medium dense, moist	ML	9-9-11-8 N=20	12	×	⊙	
				2	16	SILT (ML), little fine sand, trace fine gravel and clay, brown, medium dense, moist		8-8-10-7 N=18	14	×	⊙	
5				3	6		ML	8-10-11-11 N=21	16	×	⊙	
				4	8			10-11-11-9 N=22	14	×	⊙	
10				5	12	SILT (ML), little fine sand, trace clay and organics, brown, dense to medium dense, moist		17-21-20-18 N=41	14	×	⊙	
				6	8		ML	10-9-16-17 N=25	14	×	⊙	
20				7	16	SILT (ML), little medium to fine sand and medium to fine gravel, trace clay, brown, dense, moist	ML	20-26-24-31 N=50	6	×	⊙	
25				8	10	CLAYEY SILT (ML), little fine sand, trace fine gravel, brown, very dense, wet	ML	26-26-31-37 N=57	13	×	⊙	>>
						Boring Terminated at 27'						



Professional Service Industries, Inc.  
 3784 Commerce Court, Suite 300  
 North Tonawanda, NY 14120  
 Telephone: (716) 694-8657

**PROJECT NO.:** 0806962  
**PROJECT:** Proposed Student Housing Development  
**LOCATION:** Seven (7) Parcels of Land  
 959 Dryden Road  
 Ithaca, Tompkins County, NY 14850

**DATE STARTED:** 7/17/18  
**DATE COMPLETED:** 7/17/18  
**COMPLETION DEPTH:** 27.0 ft  
**BENCHMARK:** N/A  
**ELEVATION:** N/A  
**LATITUDE:**  
**LONGITUDE:**  
**STATION:** N/A **OFFSET:** N/A  
**REMARKS:** Hole Cave at 14.5'

**DRILL COMPANY:** NYEG Drilling  
**DRILLER:** Jesse Howe **LOGGED BY:** Steven Pump  
**DRILL RIG:** CME 850  
**DRILLING METHOD:** Hollow Stem Auger  
**SAMPLING METHOD:** 2-in SS  
**HAMMER TYPE:** Automatic  
**EFFICIENCY:** N/A  
**REVIEWED BY:** DBS

# BORING B-8

<b>Water</b>	▽ While Drilling	None feet
	▼ Upon Completion	None feet
	▽ Delay	N/A

**BORING LOCATION:**  
See Attached Boring Location Plan

Elevation (feet)	Depth (feet)	Graphic Log	Sample Type	Sample No.	Recovery (inches)	MATERIAL DESCRIPTION	USCS Classification	SPT Blows per 6-inch (SS)	Moisture, %	STRENGTH, tsf	Additional Remarks
0						3" TOPSOIL					
				1	20	FILL, medium to fine sand and silt, little fine gravel, trace clay and root fragments, brown, medium dense, moist	FILL	10-12-11-13 N=23	8	×	⊙
				2	4	FILL, silt, little medium to fine sand and clay, trace fine gravel and organics, brown, medium dense, moist	FILL	7-7-6-7 N=13	21	⊙	×
				3	2	FILL, silt and medium to fine sand, little medium to fine gravel, trace to little asphalt, brown and gray, medium dense, moist	FILL	10-11-15-17 N=26	6	×	⊙
				4	14			6-9-7-11 N=16	10	×	⊙
				5	12	CLAYEY SILT (ML), little fine sand, trace fine gravel and organics, brown, medium dense, moist	ML	7-8-9-9 N=17	21		⊙
				6	17			7-8-15-21 N=23	12	×	⊙
				7	12	SILTY SAND (SM), medium to fine sand, little medium to fine gravel, gray, very dense, moist	SM	26-38-33-46 N=71	9	×	>>⊙
				8	12	CLAYEY SILT (ML), little medium to fine gravel and medium to fine sand, brown, dense, wet	ML	16-21-26-36 N=47	10	×	⊙
						Boring Terminated at 27'					



Professional Service Industries, Inc.  
 3784 Commerce Court, Suite 300  
 North Tonawanda, NY 14120  
 Telephone: (716) 694-8657

**PROJECT NO.:** 0806962  
**PROJECT:** Proposed Student Housing Development  
**LOCATION:** Seven (7) Parcels of Land  
 959 Dryden Road  
 Ithaca, Tompkins County, NY 14850

**DATE STARTED:** 7/17/18 **DRILL COMPANY:** NYEG Drilling  
**DATE COMPLETED:** 7/17/18 **DRILLER:** Jesse Howe **LOGGED BY:** Steven Pump  
**COMPLETION DEPTH:** 27.0 ft **DRILL RIG:** CME 850  
**BENCHMARK:** N/A **DRILLING METHOD:** Hollow Stem Auger  
**ELEVATION:** N/A **SAMPLING METHOD:** 2-in SS  
**LATITUDE:** **HAMMER TYPE:** Automatic  
**LONGITUDE:** **EFFICIENCY:** N/A  
**STATION:** N/A **OFFSET:** N/A **REVIEWED BY:** DBS

# BORING B-9

<b>Water</b>	▽ While Drilling	None feet
	▼ Upon Completion	None feet
	▽ Delay	N/A

**BORING LOCATION:**  
See Attached Boring Location Plan

Elevation (feet)	Depth (feet)	Graphic Log	Sample Type	Sample No.	Recovery (inches)	MATERIAL DESCRIPTION	USCS Classification	SPT Blows per 6-inch (SS)	Moisture, %	STRENGTH, tsf	Additional Remarks
0						3" TOPSOIL					
				1	21	SILTY SAND (SM), medium to fine sand, little medium to fine gravel, trace clay, brown, medium dense, moist	SM	11-11-14-12 N=25	7	×	⊙
				2	6		SM	9-8-7-7 N=15	30	⊙	×
	5			3	2	SILTY SAND (SM), medium to fine sand, trace fine gravel, organics, and clay, brown, medium dense, moist	SM	11-11-13-11 N=24	11	×	⊙
				4	11	SANDY SILT (ML), medium to fine sand, trace fine gravel and clay, brown, medium dense, moist	ML	8-9-9-11 N=18	17	×	⊙
				5	8	SILT (ML), little clay and fine sand, trace organics, brown, medium dense, moist	ML	9-8-10-10 N=18	12	×	⊙
	15			6	10	SANDY SILT (ML), fine sand, little medium to fine gravel, trace clay and organics, brown, medium dense, moist	ML	10-9-19-23 N=28	12	×	⊙
	20			7	7	SILTY SAND (SM), medium to fine sand, little fine gravel, trace clay, gray, very dense, moist	SM	27-24-32-33 N=56	8	×	⊙ >>
	25			8	9	SILT (ML), little fine sand, trace fine gravel and clay, brown, very dense, moist	ML	22-30-33-27 N=63	11	×	⊙ >>
						Boring Terminated at 27'					



Professional Service Industries, Inc.  
 3784 Commerce Court, Suite 300  
 North Tonawanda, NY 14120  
 Telephone: (716) 694-8657

**PROJECT NO.:** 0806962  
**PROJECT:** Proposed Student Housing Development  
**LOCATION:** Seven (7) Parcels of Land  
 959 Dryden Road  
 Ithaca, Tompkins County, NY 14850



# FIELD CLASSIFICATION SYSTEM FOR SOIL EXPLORATION

## COHESIONLESS SOILS

(Silt, Sand, Gravel and Combinations)

### Density

Very Loose	5 blows per foot or less
Loose	6 - 10 blows per foot
Medium Dense	11 - 30 blows per foot
Dense	31 - 50 blows per foot
Very Dense	51 blows per foot or more

### Relative Properties

Descriptive Term	Percent
Trace	1 - 10
Little	11 - 20
Some	21 - 35
And	36 - 50

### Particle Size Identification

Boulders	8 inch diameter or more
Cobbles	3 - 8 inch diameter
Gravel	Coarse 1 - 3 inches
	Medium 1/2 - 1 inch
	Fine 1/4 - 1/2 inch
Sand	Coarse 0.6 mm - 1/4 inch (diameter of pencil lead)
	Medium 0.2 mm - 0.6 mm (diameter of broom straw)
	Fine 0.05 mm - 0.2 mm (diameter of human hair)
Silt	0.002 mm - 0.05 mm (cannot see particles)

## COHESIVE SOILS

(Clay, Silt and Combinations)

### Consistency

Very soft	3 blows per foot or less
Soft	4 - 5 blows per foot
Medim Stiff	6 - 10 blows per foot
Stiff	11 - 15 blows per foot
Very Stiff	16 - 30 blows per foot
Hard	31 blows per foot or more

### Plasticity

Degree of Plasticity	Plasticity Index
None to slight	0 - 4
Slight	5 - 7
Medium	8 - 22
High to very high	over 22

CLASSIFICATION ON LOGS ARE MADE BY VISUAL EXAMINATION OF SAMPLES.

**Standard Penetration Test** Driving a 2.0" O.D., 1 3/8" I.D., sampler a distance of 1.0 foot into undisturbed soil with a 140 pound hammer free falling a distance of 30 inches. It is customary for ITL to drive the spoon 6.0 inches to seat into undisturbed soil, then perform the test. The quantity of hammer blows for seating the sampler and performing the test are recorded for each 6.0 inches of penetration on the Field Exploration Log (example: 6-10-13). The standard penetration test result can be obtained by adding the last two figures (i.e. 10 + 13 = 23). The reader is referenced to ASTM D1586.

**Strata Changes** Boundaries between soil layers are considered approximate based upon observed changes during the drilling operations or noted changes within representative samples.

**Groundwater** Observations were made to determine either the depth or elevation of water at the times indicated on the Soil Exploration Logs. The water so encountered may be groundwater or perched water. The depth or elevations indicated for water may fluctuate due to seasonal changes or other unknown factors.

**United Soil Classification System**  
**ASTM Designation D - 2487**



Based upon percentage of material passing No. 200 sieve classify as:

- Less than 5%      **GW, GP, SW, SP**
- More than 12%    **GM, GC, SM, SC**
- 5% to 12%        **Borderline, use dual symbols**

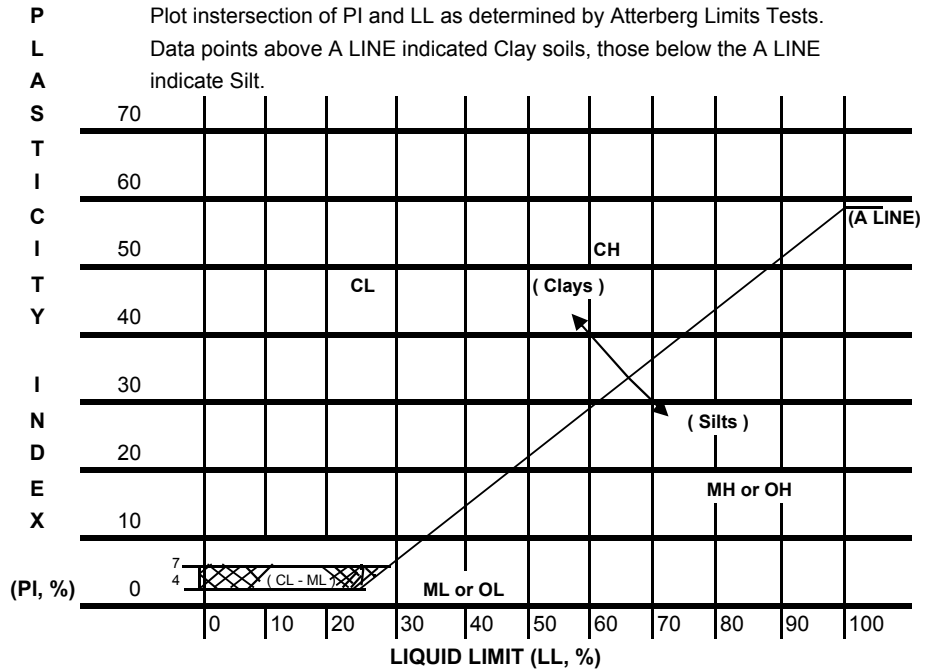

<b>Coarse Grained Soils</b>  (More than half of is larger than No. 200 sieve)	<b>Gravels (More than 50% retained on No.4 sieve)</b>	<b>GW</b>	Well graded gravels, gravel-sand mixtures, little or no fines	$C_u = \frac{D_{60}}{D_{10}} > 4$	$1 < C_c = \frac{[D_{30}]^2}{D_{10} * D_{60}} < 3$	
		<b>GP</b>	Poorly graded gravels, gravel-sand mixtures, little or no fines			Does not meet all requirements for GW
		<b>GM</b>	Silty gravels, gravel-sand-silt mixtures	below A Line, PI < 4	in shaded area 4 < PI < 7	
		<b>GC</b>	Clayey gravels, gravel-sand-clay mixtures	above A Line, PI > 7	Dual Symbols	
	<b>Sands (More than 50% passing a No. 4 sieve)</b>	<b>SW</b>	Well graded sands, gravelly sands, little or no fines	$C_u = \frac{D_{60}}{D_{10}} > 6$	$1 < C_c = \frac{[D_{30}]^2}{D_{10} * D_{60}} < 3$	
		<b>SP</b>	Poorly graded sands, gravelly sands, little or no fines			Does not meet all requirements for SW
		<b>SM</b>	Silty sands, sand-silt mixtures	below A Line, PI < 4	in shaded area	
		<b>SC</b>	Clayey sands, sand-clay mixtures	above A Line, PI > 7	4 < PI < 7 Dual Symbols	
<b>Fine Grained Soils</b>  (More than half of material is smaller than No. 200 sieve)	<b>Silts &amp; Clays (LL less than 50)</b>	<b>ML</b>	Inorganic silts, very fine sands, rock flour, silty or clayey fine sands or clayey silts with slight plasticity			
		<b>CL</b>	Inorganic clays of low to medium plasticity, gravelly clays, sandy clays, silty clays, lean clays			
		<b>OL</b>	Organic silts and organic silty clays of low plasticity			
	<b>Silts &amp; Clays (LL greater than 50)</b>	<b>MH</b>	Inorganic silts, micaceous or diatomaceous fine sandy or silty soils, plastic silts			
		<b>CH</b>	Inorganic clays of high plasticity fat clays			
		<b>OH</b>	Organic clays of medium to high plasticity			
	<b>Highly Organic Soil</b>	<b>Pt</b>	Peat and other highly organic soils			

**APPENDIX K**  
**SHPO No Impact Letter**



# Parks, Recreation, and Historic Preservation

ANDREW M. CUOMO  
Governor

ROSE HARVEY  
Commissioner

December 31, 2018

Mr. John Shields  
Project Engineer  
HUNT Engineers  
4 Commercial Street  
Rochester, NY 14614

Re: DEC  
Townhomes at Dryden  
Dryden Road and Mt. Pleasant Road, Dryden, NY  
18PR04667

Dear Mr. Shields:

Thank you for requesting the comments of the Office of Parks, Recreation and Historic Preservation (OPRHP). We have reviewed the project in accordance with the New York State Historic Preservation Act of 1980 (Section 14.09 of the New York Parks, Recreation and Historic Preservation Law). These comments are those of the OPRHP and relate only to Historic/Cultural resources. They do not include potential environmental impacts to New York State Parkland that may be involved in or near your project. Such impacts must be considered as part of the environmental review of the project pursuant to the State Environmental Quality Review Act (New York Environmental Conservation Law Article 8) and its implementing regulations (6 NYCRR Part 617).

Based upon this review, it is the New York State Office of Parks, Recreation and Historic Preservation's opinion that your project will have no impact on archaeological and/or historic resources listed in or eligible for the New York State and National Registers of Historic Places.

If further correspondence is required regarding this project, please be sure to refer to the OPRHP Project Review (PR) number noted above.

Sincerely,

Michael F. Lynch, P.E., AIA  
Director, Division for Historic Preservation

**APPENDIX L**  
**Operations and Maintenance Manual**

**SCHEDULE A**  
**Townhomes at Dryden**  
**Trinitas Ventures**  
**OPERATIONS AND MAINTENANCE MANUAL**

Background Information

The Proposed Townhomes project site is located on Dryden Road and mt. pleasant road in the town of Dryden, Tompkins County, New York. The property (Tax Map #56-5-9,11,12,19.4&19.3) is currently undeveloped and is not within a Municipal Separate Storm Sewer System (MS4). Trinitas Ventures, is proposing to construct a townhome multi-family complex with two hundred nineteen (219) units, which has six hundred and two (602) bedrooms on a 15.70-acre portion of the above-mentioned property.

The development of this property includes the construction of a parking lot with five hundred forty-one (441) parking spaces, access drive, stormwater management practices, a clubhouse, pool area with deck, retail space and landscaping. The project will disturb 16.7 acres and increase the total site impervious by 7.56 acres. The on-site stormwater management facility has been designed in accordance with the NYSDEC Design Manual and will provide the necessary water quality and quantity controls required.

The owner of the aforementioned property or his assignees shall be responsible for the proper operation and maintenance of the stormwater controls constructed on the project site.

Operations

The stormwater controls on the project site, namely the underground infiltration system and infiltration basins, have been designed in order to provide water quality and quantity controls in accordance with the NYSDEC regulations. The infiltration basin provides the quality and quantity control through infiltration of the stormwater runoff into the subsurface.

Maintenance

Once the project has been completed the permanent drainage structures will become the property of and be maintained by Trinitas Ventures. Proper inspection and maintenance of the conveyance and infiltration structures is important for their continued functionality. Accumulated sediment that is removed from the stormwater structures may be disposed of on-site if it is spread to a depth of less than 4 inches and seeded and mulched.

The following inspection and maintenance items shall be completed monthly:

- Inlet grates shall be inspected and cleaned of debris.
- Storm pipes shall be inspected and cleaned of debris.
- The Infiltration Basin shall be inspected to ensure that it dewater within 24 hours after a storm. If the basin does not dewater between storms, the sediment build up in the basin shall be removed. If the basin continues to hold water, the basin bottom shall be tilled and reseeded to ensure that topsoil compaction is not hindering infiltration. If the basin continues to hold water after tilling, an eighteen (18) inch deep and twelve (12) inch wide stone trench wrapped in filter fabric shall be installed in the basin in order to promote infiltration. If the basin continues to hold water, the owner shall contact a qualified professional for assistance.
- Complete maintenance log subsequent to inspection and maintenance.

The following inspection and maintenance items shall be completed annually:

- The infiltration basin shall be inspected for the depth of sediment. If sediment accumulation is greater than six (6) inches, the sediment shall be removed by a qualified person.
- The infiltration basin shall be inspected to ensure that no erosion is present within the basin or the basin berm and that vegetation is established. If erosion is present or vegetation is not established, the area of concern shall be returned to the proposed grade, topsoiled, and seeded.
- Complete maintenance log subsequent to inspection and maintenance.

The following inspection and maintenance items shall be completed every five (5) years:

- Inspection shall be performed and certified by a qualified inspector as defined by SPDES General Permit for Stormwater Discharges from Construction Activities.
- Inlet grates shall be inspected and cleaned of debris.
- Storm pipes shall be inspected and cleaned of debris.
- Infiltration Basin shall be inspected to ensure that it dewateres within 24 hours after a storm.
- The basin shall be inspected for the depth of sediment in the basins. If sediment accumulation is greater than six (6) inches, the sediment shall be removed by a qualified person.
- The concrete structures shall be visually inspected to determine any need for repair. Items to inspect include inlet boxes, inlet grates, etc.
- Complete maintenance log subsequent to inspection and maintenance.
- Qualified Inspector is to complete and sign inspection report.

The following is a list of equipment that may be required to inspect or maintain the stormwater facilities:

- Manhole Cover Pry Bar
- Shovel
- Stadia Rod
- Sediment Probe such as that manufactured by Sludge Judge
- Pole with skimmer/net
- Pump for dewatering
- Vacuum Truck for sediment removal
- Seed and Mulch if sediment disposed on-site or vegetation is to be established in the basins





## Table of Contents

3	<b>FIRST DEFENSE® BY HYDRO INTERNATIONAL</b>
	- INTRODUCTION
	- OPERATION
	- POLLUTANT CAPTURE AND RETENTION
4	<b>MODEL SIZES &amp; CONFIGURATIONS</b>
	- FIRST DEFENSE® COMPONENTS
5	<b>MAINTENANCE</b>
	- OVERVIEW
	- MAINTENANCE EQUIPMENT CONSIDERATIONS
	- DETERMINING YOUR MAINTENANCE SCHEDULE
6	<b>MAINTENANCE PROCEDURES</b>
	- INSPECTION
	- FLOATABLES AND SEDIMENT CLEAN OUT
8	<b>FIRST DEFENSE® INSTALLATION LOG</b>
9	<b>FIRST DEFENSE® INSPECTION AND MAINTENANCE LOG</b>

**COPYRIGHT STATEMENT:** The contents of this manual, including the graphics contained herein, are intended for the use of the recipient to whom the document and all associated information are directed. Hydro International plc owns the copyright of this document, which is supplied in confidence. It must not be used for any purpose other than that for which it is supplied and must not be reproduced, in whole or in part stored in a retrieval system or transmitted in any form or by any means without prior permission in writing from Hydro International plc. First Defense® is a trademarked hydrodynamic vortex separation device of Hydro International plc. A patent covering the First Defense® has been granted.

**DISCLAIMER:** Information and data contained in this manual is exclusively for the purpose of assisting in the operation and maintenance of Hydro International plc's First Defense®. No warranty is given nor can liability be accepted for use of this information for any other purpose. Hydro International plc has a policy of continuous product development and reserves the right to amend specifications without notice.

## I. First Defense® by Hydro International

### Introduction

The First Defense® is an enhanced vortex separator that combines an effective and economical stormwater treatment chamber with an integral peak flow bypass. It efficiently removes total suspended solids (TSS), trash and hydrocarbons from stormwater runoff without washing out previously captured pollutants. The First Defense® is available in several model configurations (refer to *Section II. Model Sizes & Configurations*, page 4) to accommodate a wide range of pipe sizes, peak flows and depth constraints.

### Operation

The First Defense® operates on simple fluid hydraulics. It is self-activating, has no moving parts, no external power requirement and is fabricated with durable non-corrosive components. No manual procedures are required to operate the unit and maintenance is limited to monitoring accumulations of stored pollutants and periodic clean-outs. The First Defense® has been designed to allow for easy and safe access for inspection, monitoring and clean-out procedures. Neither entry into the unit nor removal of the internal components is necessary for maintenance, thus safety concerns related to confined-space-entry are avoided.

### Pollutant Capture and Retention

The internal components of the First Defense® have been designed to optimize pollutant capture. Sediment is captured and retained in the base of the unit, while oil and floatables are stored on the water surface in the inner volume (Fig.1).

The pollutant storage volumes are isolated from the built-in bypass chamber to prevent washout during high-flow storm events. The sump of the First Defense® retains a standing water level between storm events. This ensures a quiescent flow regime at the onset of a storm, preventing resuspension and washout of pollutants captured during previous events.

Accessories such as oil absorbent pads are available for enhanced oil removal and storage. Due to the separation of the oil and floatable storage volume from the outlet, the potential for washout of stored pollutants between clean-outs is minimized.

### Applications

- Stormwater treatment at the point of entry into the drainage line
- Sites constrained by space, topography or drainage profiles with limited slope and depth of cover
- Retrofit installations where stormwater treatment is placed on or tied into an existing storm drain line
- Pretreatment for filters, infiltration and storage

### Advantages

- Inlet options include surface grate or multiple inlet pipes
- Integral high capacity bypass conveys large peak flows without the need for "offline" arrangements using separate junction manholes
- Proven to prevent pollutant washout at up to 500% of its treatment flow
- Long flow path through the device ensures a long residence time within the treatment chamber, enhancing pollutant settling
- Delivered to site pre-assembled and ready for installation

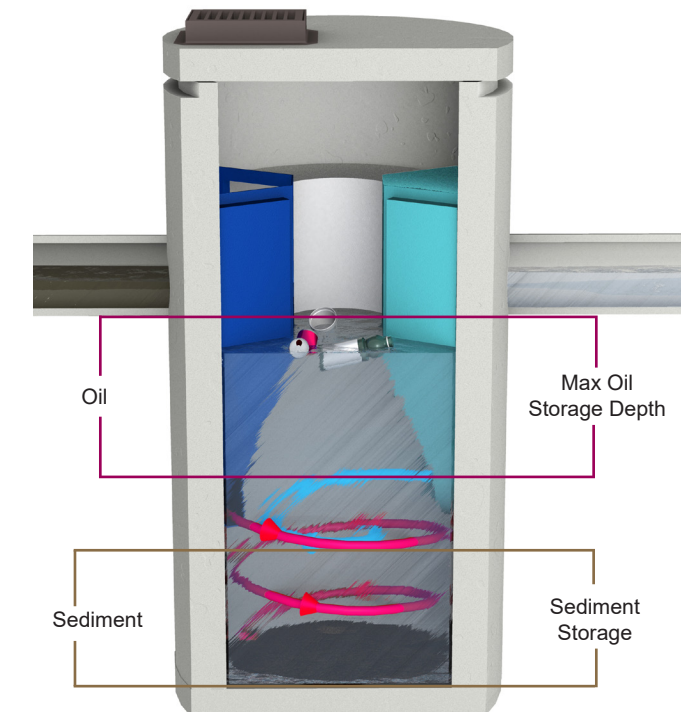

Fig.1 Pollutant storage volumes in the First Defense®.

## II. Model Sizes & Configurations

The First Defense® inlet and internal bypass arrangements are available in several model sizes and configurations. The components of the First Defense®-4HC and First Defense®-6HC have modified geometries as to allow greater design flexibility needed to accommodate various site constraints.

All First Defense® models include the internal components that are designed to remove and retain total suspended solids (TSS), gross solids, floatable trash and hydrocarbons (Fig.2a - 2b). First Defense® model parameters and design criteria are shown in Table 1.

### First Defense® Components

1. Built-In Bypass
2. Inlet Pipe
3. Inlet Chute
4. Floatables Draw-off Port
5. Outlet Pipe
6. Floatables Storage
7. Sediment Storage
8. Inlet Grate or Cover

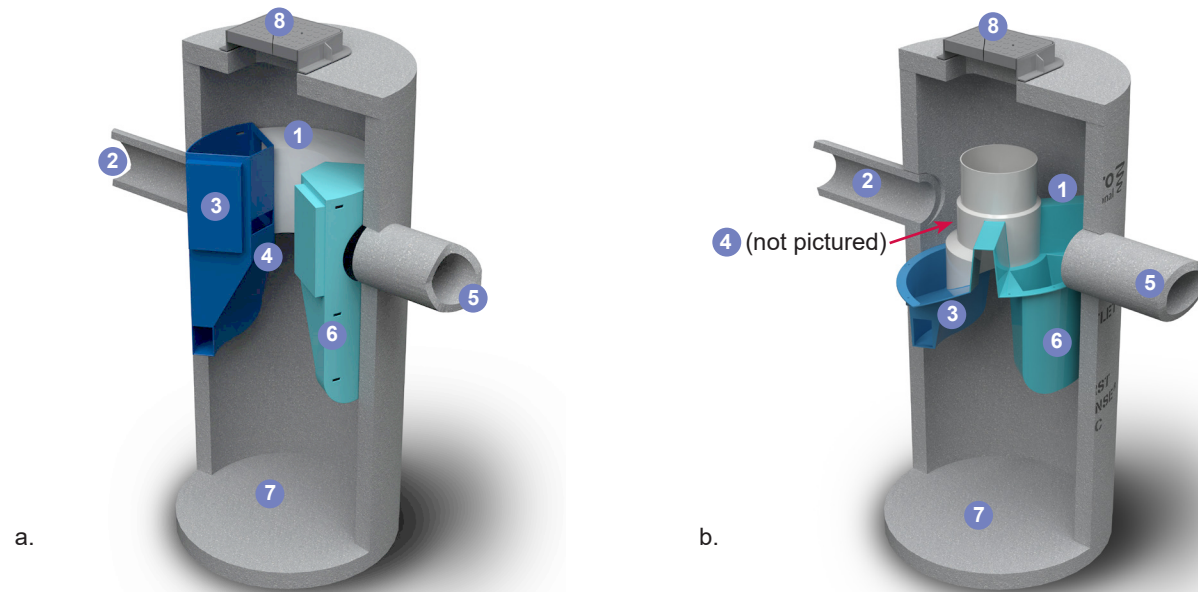

Fig.2a) First Defense®-4 and First Defense®-6; b) First Defense®-4HC and First Defense®-6HC, with higher capacity dual internal bypass and larger maximum pipe diameter.

First Defense® High Capacity Model Number	Diameter	Typical TSS Treatment Flow Rates	Peak Online Flow Rate	Maximum Pipe Diameter <sup>1</sup>	Oil Storage Capacity	Typical Sediment Storage Capacity <sup>2</sup>	Minimum Distance from Outlet Invert to Top of Rim <sup>3</sup>	Chamber Depth
		NJDEP Certified						
	(ft / m)	(cfs / L/s)	(cfs / L/s)	(in / mm)	(gal / L)	(yd <sup>3</sup> / m <sup>3</sup> )	(ft / m)	(ft / m)
FD-3HC	3 / 0.9	0.85 / 24.0	15 / 424	18 / 457	125 / 473	0.4 / 0.3	2.0 - 3.5 / 0.6 - 1.0	3.75 / 1.14
FD-4HC	4 / 1.2	1.50 / 42.4	18 / 510	24 / 600	191 / 723	0.7 / 0.5	2.3 - 3.9 / 0.7 - 1.2	5.00 / 1.52
FD-5HC	5 / 1.5	2.35 / 66.2	20 / 566	24 / 609	300 / 1135	1.1 / .84	2.5 - 4.5 / 0.7 - 1.3	5.25 / 1.60
FD-6HC	6 / 1.8	3.38 / 95.7	32 / 906	30 / 750	496 / 1878	1.6 / 1.2	3.0 - 5.1 / 0.9 - 1.6	6.25 / 1.90
FD-7HC	7 / 2.1	4.60 / 130.2	40 / 1133	42 / 1067	750 / 2839	2.1 / 1.9	3.0 - 5.5 / 0.9 - 1.7	7.25 / 2.20
FD-8HC	8 / 2.4	6.00 / 169.9	50 / 1,415	48 / 1219	1120 / 4239	2.8 / 2.1	3.0 - 6.0 / 0.9 - 1.8	8.00 / 2.43

<sup>1</sup>Contact Hydro International when larger pipe sizes are required.  
<sup>2</sup>Contact Hydro International when custom sediment storage capacity is required.  
<sup>3</sup>Minimum distance for models depends on pipe diameter.

## III. Maintenance

### Overview

The First Defense® protects the environment by removing a wide range of pollutants from stormwater runoff. Periodic removal of these captured pollutants is essential to the continuous, long-term functioning of the First Defense®. The First Defense® will capture and retain sediment and oil until the sediment and oil storage volumes are full to capacity. When sediment and oil storage capacities are reached, the First Defense® will no longer be able to store removed sediment and oil. Maximum pollutant storage capacities are provided in Table 1.

The First Defense® allows for easy and safe inspection, monitoring and clean-out procedures. A commercially or municipally owned sump-vac is used to remove captured sediment and floatables. Access ports are located in the top of the manhole.

Maintenance events may include Inspection, Oil & Floatables Removal, and Sediment Removal. Maintenance events do not require entry into the First Defense®, nor do they require the internal components of the First Defense® to be removed. In the case of inspection and floatables removal, a vactor truck is not required. However, a vactor truck is required if the maintenance event is to include oil removal and/or sediment removal.

### Maintenance Equipment Considerations

The internal components of the First Defense®-HC have a centrally located circular shaft through which the sediment storage sump can be accessed with a sump vac hose. The open diameter of this access shaft is 15 inches in diameter (Fig.3). Therefore, the nozzle fitting of any vactor hose used for maintenance should be less than 15 inches in diameter.

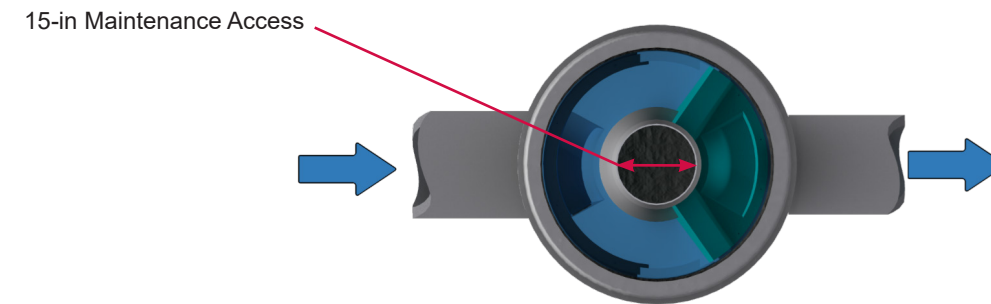

Fig.3 The central opening to the sump of the First Defense®-HC is 15 inches in diameter.

### Determining Your Maintenance Schedule

The frequency of clean out is determined in the field after installation. During the first year of operation, the unit should be inspected every six months to determine the rate of sediment and floatables accumulation. A simple probe such as a Sludge-Judge® can be used to determine the level of accumulated solids stored in the sump. This information can be recorded in the maintenance log (see page 9) to establish a routine maintenance schedule.

The vactor procedure, including both sediment and oil / floatables removal, for a 6-ft First Defense® typically takes less than 30 minutes and removes a combined water/oil volume of about 765 gallons.



**Inspection Procedures**

1. Set up any necessary safety equipment around the access port or grate of the First Defense® as stipulated by local ordinances. Safety equipment should notify passing pedestrian and road traffic that work is being done.
2. Remove the grate or lid to the manhole.
3. Without entering the vessel, look down into the chamber to inspect the inside. Make note of any irregularities. Fig.4 shows the standing water level that should be observed.
4. Without entering the vessel, use the pole with the skimmer net to remove floatables and loose debris from the components and water surface.
5. Using a sediment probe such as a Sludge Judge®, measure the depth of sediment that has collected in the sump of the vessel.
6. On the Maintenance Log (see page 9), record the date, unit location, estimated volume of floatables and gross debris removed, and the depth of sediment measured. Also note any apparent irregularities such as damaged components or blockages.
7. Securely replace the grate or lid.
8. Take down safety equipment.
9. Notify Hydro International of any irregularities noted during inspection.

**Floatables and Sediment Clean Out**

Floatables clean out is typically done in conjunction with sediment removal. A commercially or municipally owned sump-vac is used to remove captured sediment and floatables (Fig.5).

Floatables and loose debris can also be netted with a skimmer and pole. The access port located at the top of the manhole provides unobstructed access for a vactor hose and skimmer pole to be lowered to the base of the sump.

**Scheduling**

- Floatables and sump clean out are typically conducted once a year during any season.
- Floatables and sump clean out should occur as soon as possible following a spill in the contributing drainage area.



Fig.4 Floatables are removed with a vactor hose (First Defense model FD-4, shown).

**Recommended Equipment**

- Safety Equipment (traffic cones, etc)
- Crow bar or other tool to remove grate or lid
- Pole with skimmer or net (if only floatables are being removed)
- Sediment probe (such as a Sludge Judge®)
- Vactor truck (flexible hose recommended)
- First Defense® Maintenance Log

**Floatables and sediment Clean Out Procedures**

1. Set up any necessary safety equipment around the access port or grate of the First Defense® as stipulated by local ordinances. Safety equipment should notify passing pedestrian and road traffic that work is being done.
2. Remove the grate or lid to the manhole.
3. Without entering the vessel, look down into the chamber to inspect the inside. Make note of any irregularities.
4. Remove oil and floatables stored on the surface of the water with the vactor hose (Fig.5) or with the skimmer or net (not pictured).
5. Using a sediment probe such as a Sludge Judge®, measure the depth of sediment that has collected in the sump of the vessel and record it in the Maintenance Log (page 9).
6. Once all floatables have been removed, drop the vactor hose to the base of the sump. Vactor out the sediment and gross debris off the sump floor (Fig.5).
7. Retract the vactor hose from the vessel.
8. On the Maintenance Log provided by Hydro International, record the date, unit location, estimated volume of floatables and gross debris removed, and the depth of sediment measured. Also note any apparent irregularities such as damaged components, blockages, or irregularly high or low water levels.
9. Securely replace the grate or lid.



Fig.5 Sediment is removed with a vactor hose (First Defense model FD-4, shown).

**Maintenance at a Glance**

Inspection	- Regularly during first year of installation - Every 6 months after the first year of installation
Oil and Floatables Removal	- Once per year, with sediment removal - Following a spill in the drainage area
Sediment Removal	- Once per year or as needed - Following a spill in the drainage area

NOTE: For most clean outs the entire volume of liquid does not need to be removed from the manhole. Only remove the first few inches of oils and floatables from the water surface to reduce the total volume of liquid removed during a clean out.





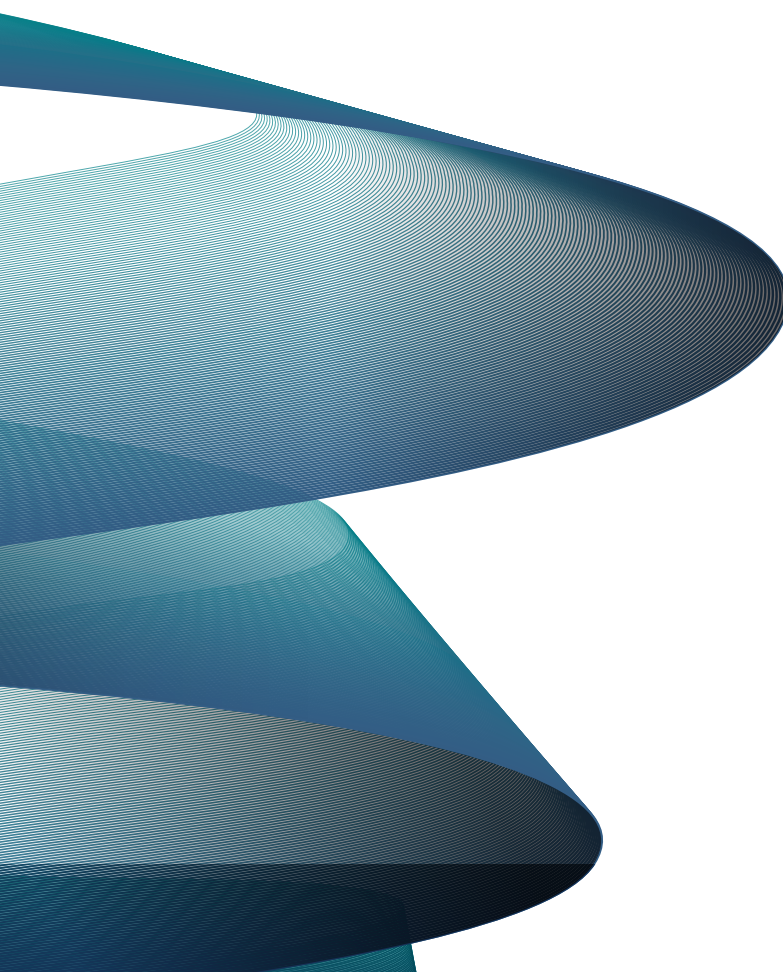

## Stormwater Solutions

94 Hutchins Drive  
Portland, ME 04102

Tel: (207) 756-6200

Fax: (207) 756-6212

[stormwaterinquiry@hydro-int.com](mailto:stormwaterinquiry@hydro-int.com)

[www.hydro-int.com](http://www.hydro-int.com)

**APPENDIX 1**  
**Maintenance Log**

## Maintenance Log for Townhomes at Dryden

For Year \_\_\_\_\_

		January	February	March	April	May	June
Items to be completed Monthly	<b>Inlet Grates Clear of Debris</b>						
	Inspected						
	Cleaned? (or N/A)						
	<b>Storm Pipes Clear of Debris</b>						
	Inspected						
	Cleaned? (or N/A)						
	<b>Basin Dewaterers Between Storms</b>						
	Inspected						
	Cleaned? (or N/A)						
	<b>Other Comments</b>						
<b>Inspected and Maintained by:</b>							

		July	August	September	October	November	December
Items to be completed Monthly	<b>Inlet Grates Clear of Debris</b>						
	Inspected						
	Cleaned? (or N/A)						
	<b>Storm Pipes Clear of Debris</b>						
	Inspected						
	Cleaned? (or N/A)						
	<b>Basin Dewaterers within 24 hours</b>						
	Inspected						
	Cleaned? (or N/A)						
	<b>Other Comments</b>						
<b>Inspected and Maintained by:</b>							

**Date Inspected:**

Items to be completed Annually	<b>Basin</b>	
	Depth of Sediment	
	Sediment Removed? (or N/A)	
	Vegetation in good condition?	
	Any erosion in basin or on berm?	
	<b>Other Comments</b>	
	<b>Inspected and Maintained by:</b>	



## **APPENDIX 2**

### **Inspection Report for Qualified Inspector**

# Inspection Report for Townhomes at Dryden

Date of Inspection: \_\_\_\_\_

Inspected By: \_\_\_\_\_

<b>Inlet Grates Clear of Debris</b>	
Inspected	
Cleaned? (or N/A)	
<b>Storm Pipes Clear of Debris</b>	
Inspected	
Cleaned? (or N/A)	
<b>Basins Dewater within 24 hours</b>	
Inspected	
Cleaned? (or N/A)	
<b>Sediment in Basin</b>	
Depth of Sediment	
Sediment Removed? (or N/A)	
Vegetation in good condition?	
Any erosion in basin or on berm?	
<b>Storm infiltration system</b>	
Depth of Sediment	
Sediment Removed? (or N/A)	

**Other Comments:**

---

---

---

---

**Recommendations:**

---

---

---

---

I certify that 1. I am a qualified inspector as defined by the SPDES General Permit for Stormwater Discharge from Construction Activities, 2. the items listed above have been inspected and observed in accordance with the Operations and Maintenance Manual, and 3. the stormwater controls inspected are generally operating as intended.

\_\_\_\_\_  
Printed Name

\_\_\_\_\_  
Signature

\_\_\_\_\_  
Date

**APPENDIX M**  
**Construction Site Log Book**

**STATE POLLUTANT DISCHARGE ELIMINATION SYSTEM FOR CONSTRUCTION  
ACTIVITIES**

**CONSTRUCTION SITE LOG BOOK**

For

**Trinitas Ventures  
Townhomes at Dryden  
HUNT #3177-001  
October 2018**

**TABLE OF CONTENTS**

- I. Pre-Construction Meeting Documents
  - a. Preamble to Site Assessment and Inspections
  - b. Qualified Professional's Credentials & Certification
  - c. Pre-Construction Site Assessment Checklist
  
- II. Construction Duration Inspection Documents
  - a. Directions
  - b. Blank Inspection Forms
  - c. Blank Modification to the SWPPP
  
- III. Materials Handling and Spill Prevention
  
- IV. Completed Inspection Reports
  
- V. Completed Modifications to the SWPPP

**I. PRE-CONSTRUCTION MEETING DOCUMENTS**

**Project Name** \_\_\_\_\_

**Permit No.** \_\_\_\_\_ **Date of Authorization** \_\_\_\_\_

**Name of Operator** \_\_\_\_\_

**Prime Contractor** \_\_\_\_\_

**a. Preamble to Site Assessment and Inspections**

The Following Information to be read by all person's involved in The Construction of Stormwater Related Activities:

The Operator agrees to have a qualified professional<sup>1</sup> conduct an assessment of the site prior to the commencement of construction<sup>2</sup> and certify in this inspection report that the appropriate erosion and sediment controls described in the SWPPP have been adequately installed or implemented to ensure overall preparedness of the site for the commencement of construction.

Prior to the commencement of construction, the Operator shall certify in this site logbook that the SWPPP has been prepared in accordance with the State's standards and meets all Federal, State and local erosion and sediment control requirements.

When construction starts, site inspections shall be conducted by the qualified professional at least every 7 calendar days and within 24 hours of the end of a storm event of 0.5 inches or greater (Construction Duration Inspections). The Operator shall maintain a record of all inspection reports in this site logbook. The site logbook shall be maintained on site and be made available to the permitting authorities upon request.

Prior to filing the Notice of Termination or the end of permit term, the Operator shall have a qualified professional perform a final site inspection. The qualified professional shall certify that the site has undergone final stabilization<sup>3</sup> using either vegetative or structural stabilization methods and that all temporary erosion and sediment controls (such as silt fencing) not needed for long-term erosion control have been removed. In addition, the Operator must identify and certify that all permanent structures described in the SWPPP have been constructed and provide the owner(s) with an operation and maintenance plan that ensures the structure(s) continuously functions as designed.

- |   |
|---|
| <ol style="list-style-type: none"><li>1) "Qualified Professional means a person knowledgeable in the principles and practice of erosion and sediment controls, such as a Certified Professional in Erosion and Sediment Control (CPESC), soil scientist, licensed engineer or someone working under the direction and supervision of a licensed engineer (person must have experience in the principles and practices of erosion and sediment control).</li><li>2) "Commencement of construction" means the initial removal of vegetation and disturbance of soils associated with clearing, grading or excavating activities or other construction activities.</li><li>3) "Final stabilization" means that all soil-disturbing activities at the site have been completed and a uniform, perennial vegetative cover with a density of eighty (80) percent has been established or equivalent stabilization measures (such as the use of mulches or geotextiles) have been employed on all unpaved areas and areas not covered by permanent structures.</li></ol> |
|---|

**b. Qualified Professional's Credentials & Certification**

"I hereby certify that I meet the criteria set forth in the General Permit to conduct site inspections for this project and that the appropriate erosion and sediment controls described in the SWPPP and as described in the following Pre-construction Site Assessment Checklist have been adequately installed or implemented, ensuring the overall preparedness of this site for the commencement of construction."

**Name (please print):** \_\_\_\_\_

**Title:** \_\_\_\_\_ **Date:** \_\_\_\_\_

**Address:** \_\_\_\_\_

**Phone:** \_\_\_\_\_ **Email:** \_\_\_\_\_

**Signature:** \_\_\_\_\_

**c. Pre-construction Site Assessment Checklist**  
**(NOTE: Provide comments below as necessary)**

1. Notice of Intent, SWPPP, and Contractors Certification:

**Yes No NA**

- Has a Notice of Intent been filed with the NYS Department of Conservation?
- Is the SWPPP on-site? Where? \_\_\_\_\_
- Is the Plan current? What is the latest revision date? \_\_\_\_\_
- Is a copy of the NOI (with brief description) onsite? Where? \_\_\_\_\_
- Have all contractors involved with stormwater related activities signed a contractor's certification?

2. Resource Protection

**Yes No NA**

- Are construction limits clearly flagged or fenced?
- Important trees and associated rooting zones, on-site septic system absorption fields, existing vegetated areas suitable for filter strips, especially in perimeter areas, have been flagged for protection.
- Creek crossings installed prior to land-disturbing activity, including clearing and blasting.

3. Surface Water Protection

**Yes No NA**

- Clean stormwater runoff has been diverted from areas to be disturbed.
- Bodies of water located either on site or in the vicinity of the site have been identified and protected.
- Appropriate practices to protect on-site or downstream surface water are installed.
- Are clearing and grading operations divided into areas <5 acres?

4. Stabilized Construction Entrance

**Yes No NA**

- A temporary construction entrance to capture mud and debris from construction vehicles before they enter the public highway has been installed.
- Other access areas (entrances, construction routes, equipment parking areas) are stabilized immediately as work takes place with gravel or other cover.
- Sediment tracked onto public streets is removed or cleaned on a regular basis.

5. Perimeter Sediment Controls

**Yes No NA**

- Silt sock material and installation comply with the standard drawing and specifications.
- Silt socks are installed at appropriate spacing intervals.
- Sediment trap was installed as first land disturbing activity.
- Sediment traps and barriers are installed.

6. Pollution Prevention for Waste and Hazardous Materials

**Yes No NA**

- The Operator or designated representative has been assigned to implement the spill prevention avoidance and response plan.
- The contractor maintains a Spill Prevention Control and Counter Measures Program. A supplemental Materials Handling and Spill Prevention plan is contained in Section III of this log book.

Appropriate materials to control spills are onsite. Where? \_\_\_\_\_

## II. CONSTRUCTION DURATION INSPECTION DOCUMENTS

### a. Directions:

**Inspection Forms will be filled out during the entire construction phase of the project.**

Required Elements:

- (1) On a site map, indicate the extent of all disturbed site areas and drainage pathways. Indicate site areas that are expected to undergo initial disturbance or significant site work within the next 14-day period;
- (2) Indicate on a site map all areas of the site that have undergone temporary or permanent stabilization;
- (3) Indicate all disturbed site areas that have not undergone active site work during the previous 14-day period;
- (4) Inspect all sediment control practices and record the approximate degree of sediment accumulation as a percentage of sediment storage volume (for example, 10 percent, 20 percent, 50 percent);
- (5) Inspect all erosion and sediment control practices and record all maintenance requirements such as verifying the integrity of barrier or diversion systems (earthen berms or silt fencing) and containment systems (sediment basins and sediment traps). Identify any evidence of rill or gully erosion occurring on slopes and any loss of stabilizing vegetation or seeding/mulching. Document any excessive deposition of sediment or ponding water along barrier or diversion systems. Record the depth of sediment within containment structures, any erosion near outlet and overflow structures, and verify the ability of rock filters around perforated riser pipes to pass water; and
- (6) Immediately report to the Operator any deficiencies that are identified with the implementation of the SWPPP.

**CONSTRUCTION DURATION INSPECTIONS**

Page 1 of \_\_\_\_\_  
DATE \_\_\_\_\_  
BY \_\_\_\_\_

**SITE PLAN/SKETCH**

\_\_\_\_\_  
**Inspector (print name)**

\_\_\_\_\_  
**Date of Inspection**

\_\_\_\_\_  
**Qualified Professional (print name)**

\_\_\_\_\_  
**Qualified Professional Signature**

The above signed acknowledges that, to the best of his/her knowledge, all information provided on the forms is accurate and complete.



**CONSTRUCTION DURATION INSPECTIONS**

Page 2 of \_\_\_\_\_  
DATE \_\_\_\_\_  
BY \_\_\_\_\_

**Maintaining Water Quality**

**Yes No NA**

- Is there an increase in turbidity causing a substantial visible contrast to natural conditions?
- Is there residue from oil and floating substances, visible oil film, or globules or grease?
- All disturbance is within the limits of the approved plans.
- Have receiving lake/bay, stream, and/or wetland been impacted by silt from project?

**Housekeeping**

1. General Site Conditions

**Yes No NA**

- Is construction site litter and debris appropriately managed?
- Are facilities and equipment necessary for implementation of erosion and sediment control in working order and/or properly maintained?
- Is construction impacting the adjacent property?
- Is dust adequately controlled?

2. Temporary Stream Crossing

**Yes No NA**

- Maximum diameter pipes necessary to span creek without dredging are installed.
- Installed non-woven geotextile fabric beneath approaches.
- Is fill composed of aggregate (no earth or soil)?
- Rock on approaches is clean enough to remove mud from vehicles & prevent sediment from entering stream during high flow.

**Runoff Control Practices**

1. Excavation Dewatering

**Yes No NA**

- Upstream and downstream berms (sandbags, inflatable dams, etc.) are installed per plan.
- Clean water from upstream pool is being pumped to the downstream pool.
- Sediment laden water from work area is being discharged to a silt-trapping device.
- Constructed upstream berm with one-foot minimum freeboard.

2. Level Spreader

**Yes No NA**

- Installed per plan.
- Constructed on undisturbed soil, not on fill, receiving only clear, non-sediment laden flow.
- Flow sheets out of level spreader without erosion on downstream edge.

3. Interceptor Dikes and Swales

**Yes No NA**

- Installed per plan with minimum side slopes 2H:1V or flatter.
- Stabilized by geotextile fabric, seed, or mulch with no erosion occurring.

Sediment-laden runoff directed to sediment trapping structure  
**CONSTRUCTION DURATION INSPECTIONS**

Page 3 of \_\_\_\_\_  
DATE \_\_\_\_\_  
BY \_\_\_\_\_

**Runoff Control Practices (continued)**

4. Stone Check Dam

**Yes No NA**

- Is channel stable? (flow is not eroding soil underneath or around the structure).
- Check is in good condition (rocks in place and no permanent pools behind the structure).
- Has accumulated sediment been removed?

5. Rock Outlet Protection

**Yes No NA**

- Installed per plan.
- Installed concurrently with pipe installation.

**Soil Stabilization**

1. Topsoil and Spoil Stockpiles

**Yes No NA**

- Stockpiles are stabilized with vegetation and/or mulch.
- Sediment control is installed at the toe of the slope.

2. Revegetation

**Yes No NA**

- Temporary seedings and mulch have been applied to idle areas.
- 4 inches minimum of topsoil has been applied under permanent seedings.

**Sediment Control Practices**

1. Stabilized Construction Entrance

**Yes No NA**

- Stone is clean enough to effectively remove mud from vehicles.
- Installed per standards and specifications?
- Does all traffic use the stabilized entrance to enter and leave site?
- Is adequate drainage provided to prevent ponding at entrance?

2. Silt Sock

**Yes No NA**

- Installed on Contour, 10 feet from toe of slope (not across conveyance channels).
- Joints constructed by butting the two ends securely together.
- Proper staking has been provided.
- Socks are in adequate condition without rips or frayed areas.  
Sediment accumulation is \_\_\_\_\_% of design capacity.

**CONSTRUCTION DURATION INSPECTIONS**

Page 4 of \_\_\_\_\_  
DATE \_\_\_\_\_  
BY \_\_\_\_\_

**Sediment Control Practices (continued)**

3. Storm Drain Inlet Protection

**Yes No NA**

- Inlet protections are installed per plan.
- Installed protections are in adequate, undamaged conditions.
- Drainage area is 1 acre or less.
- Sediment accumulation is \_\_\_\_\_% of design capacity.

4. Temporary Sediment Trap

**Yes No NA**

- Trap and outlet structure is constructed per the approved plan or drawing.
- Side slopes are stabilized with seed/mulch.
- Drainage structure flushed and basin surface restored upon removal of sediment basin facility.  
Sediment accumulation is \_\_\_\_\_% of design capacity.

5. Temporary Sediment Basin

**Yes No NA**

- Basin and outlet structure constructed per the approved plan.
- Basin side slopes are stabilized with seed/mulch.
- Drainage structure flushed and basin surface restored upon removal of sediment basin facility.  
Sediment accumulation is \_\_\_\_\_% of design capacity.

**Action Items and Required Maintenance**

**Yes No NA**

- All previous action and maintenance items have been addressed.

**ACTIONS/MAINTENANCE REQUIRED**

Area	Action/Maintenance Item	Responsible Party



### III. MATERIALS HANDLING AND SPILL PREVENTION

The Contractor shall follow all Federal, State and local regulations pertaining to material handling, spill prevention and spill cleanup. The Contractor shall notify the appropriate agencies when a spill occurs. The following are recommended guidelines for the Contractor and shall not replace governmental regulations:

**Concrete Washout Structure:** Concrete Washout Structures are used to contain concrete and liquids when the chutes of concrete mixers and hoppers of concrete pumps are rinsed out after delivery. The washout facilities can be constructed or ready-made. All washout facilities consolidate solids for easier disposal and prevent runoff of liquids. The wash water is alkaline and contains high levels of chromium, which can leach into the ground and contaminate groundwater. It can also migrate to a storm drain, which can increase the pH of nearby waterways and harm aquatic life.

- The Contractor shall designate a concrete washout area and shall install the washout a minimum of 100 feet upstream from a storm drain, stream, pond or waterway.
- The facilities shall be cleaned out once they are 2/3 full or new facilities be constructed to provide additional storage.
- Adding solvents, flocculent, or acid to washwater is prohibited.
- Permanent disposal of concrete washout waste on the construction site is prohibited. Disposal of waste shall be in a legal manor.

**Construction Site Liquid and Solid Waste Management:** Building materials and other construction site wastes, including sanitary wastes, must be properly managed and disposed of to reduce the risk of pollution. Practices such as trash disposal, recycling, proper sanitary facility maintenance, and spill prevention and cleanup measures can reduce the potential for stormwater runoff to mobilize construction site wastes and contaminate surface or ground water.

- The Contractor shall designate one area for construction vehicle refueling that is at least 100 feet away from a storm drain, stream, pond or waterway.
- Temporary sanitary facilities should be located at least 50 feet away from drainageways, storm drains, receiving waters, areas of high traffic, and areas susceptible to flooding. Wastewater generated from sanitary facilities shall not be allowed to flow into storm sewers and drainageways. Only licensed haulers shall be authorized to dispose of waste. Facilities shall be secured to prevent overturning in areas susceptible to strong winds.
- Construction waste shall be segregated properly into various categories such as hazardous materials, toxic liquids and non-hazardous materials.
- Containers of liquids should have secondary containment and be stored away from drainageways, storm drains, receiving waters, areas of high traffic, and areas susceptible to flooding. Containers shall also be properly labeled.

**Spill Prevention and Control:** Spill Prevention, Control and Counter Measure Plan (SPCC) shall clearly state measures to stop the source of a spill, contain the spill, clean up the spill, dispose of contaminated materials, and train personnel to prevent and control future spills. SPCCs are applicable to construction sites where hazardous waste are stored or used. Hazardous waste includes pesticides, paints, cleaners, petroleum products, fertilizers, and solvents.

- The Contractor shall develop and implement a Spill Prevention, Control and Counter Measure Plan in conformance with State and Federal Regulations.
- Spills shall be contained and cleaned up as soon as possible.
- Residuals left over from the clean up activity, such as absorbent pads or containers of spill material, shall be disposed of properly.
- Proper spill and illicit discharge reporting procedures including calling NYS DEC hotline (1-800-457-7362) shall be followed for both hazardous and non-hazardous materials.
- Spills shall not be washed down into the storm drain or buried anywhere.
- The Contractor shall refer to NYS DEC Spill Guidance Manual (SGM) for additional requirements.

**SECTION IV – COMPLETED INSPECTION REPORTS**

**SECTION V – COMPLETED MODIFICATIONS TO THE SWPPP**

**APPENDIX N**

**SPDES General Permit for Stormwater Discharges from a Construction Activity  
(Permit No. GP-0-15-002)**





Department of  
Environmental  
Conservation

NEW YORK STATE  
DEPARTMENT OF ENVIRONMENTAL CONSERVATION  
SPDES GENERAL PERMIT  
FOR STORMWATER DISCHARGES

From

**CONSTRUCTION ACTIVITY**

Permit No. GP-0-15-002

Issued Pursuant to Article 17, Titles 7, 8 and Article 70  
of the Environmental Conservation Law

Effective Date: January 29, 2015

Expiration Date: January 28, 2020

Modification Date:

July 14, 2015 – Correction of typographical error in definition of “New Development”,  
Appendix A

November 23, 2016 – Updated to require the use of the New York State Standards and  
Specifications for Erosion and Sediment Control, dated November  
2016. The use of this standard will be required as of February 1,  
2017.

John J. Ferguson  
Chief Permit Administrator

  
Authorized Signature

11.14.16  
Date

Address: NYS DEC  
Division of Environmental Permits  
625 Broadway, 4th Floor  
Albany, N.Y. 12233-1750



## PREFACE

Pursuant to Section 402 of the Clean Water Act (“CWA”), stormwater *discharges* from certain *construction activities* are unlawful unless they are authorized by a *National Pollutant Discharge Elimination System (“NPDES”)* permit or by a state permit program. New York’s *State Pollutant Discharge Elimination System (“SPDES”)* is a NPDES-approved program with permits issued in accordance with the *Environmental Conservation Law (“ECL”)*.

This general permit (“permit”) is issued pursuant to Article 17, Titles 7, 8 and Article 70 of the ECL. An *owner or operator* may obtain coverage under this permit by submitting a Notice of Intent (“NOI”) to the Department. Copies of this permit and the NOI for New York are available by calling (518) 402-8109 or at any New York State Department of Environmental Conservation (“the Department”) regional office (see Appendix G). They are also available on the Department’s website at:

<http://www.dec.ny.gov/>

An *owner or operator* of a *construction activity* that is eligible for coverage under this permit must obtain coverage prior to the *commencement of construction activity*. Activities that fit the definition of “*construction activity*”, as defined under 40 CFR 122.26(b)(14)(x), (15)(i), and (15)(ii), constitute construction of a point source and therefore, pursuant to Article 17-0505 of the ECL, the *owner or operator* must have coverage under a SPDES permit prior to *commencing construction activity*. They cannot wait until there is an actual *discharge* from the construction site to obtain permit coverage.

**\*Note: The italicized words/phrases within this permit are defined in Appendix A.**

**NEW YORK STATE DEPARTMENT OF ENVIRONMENTAL CONSERVATION  
 SPDES GENERAL PERMIT FOR STORMWATER DISCHARGES  
 FROM CONSTRUCTION ACTIVITIES**

Part I. PERMIT COVERAGE AND LIMITATIONS .....	1
A. Permit Application .....	1
B. Effluent Limitations Applicable to Discharges from Construction Activities .....	1
C. Post-construction Stormwater Management Practice Requirements .....	4
D. Maintaining Water Quality .....	8
E. Eligibility Under This General Permit.....	9
F. Activities Which Are Ineligible for Coverage Under This General Permit .....	9
Part II. OBTAINING PERMIT COVERAGE .....	12
A. Notice of Intent (NOI) Submittal .....	12
B. Permit Authorization.....	13
C. General Requirements For Owners or Operators With Permit Coverage .....	15
D. Permit Coverage for Discharges Authorized Under GP-0-10-001 .....	17
E. Change of <i>Owner or Operator</i> .....	17
Part III. STORMWATER POLLUTION PREVENTION PLAN (SWPPP).....	18
A. General SWPPP Requirements .....	18
B. Required SWPPP Contents .....	20
C. Required SWPPP Components by Project Type.....	23
Part IV. INSPECTION AND MAINTENANCE REQUIREMENTS .....	24
A. General Construction Site Inspection and Maintenance Requirements .....	24
B. Contractor Maintenance Inspection Requirements .....	24
C. Qualified Inspector Inspection Requirements.....	24
Part V. TERMINATION OF PERMIT COVERAGE .....	28
A. Termination of Permit Coverage .....	28
Part VI. REPORTING AND RETENTION OF RECORDS .....	30
A. Record Retention .....	30
B. Addresses .....	30
Part VII. STANDARD PERMIT CONDITIONS.....	31
A. Duty to Comply.....	31
B. Continuation of the Expired General Permit.....	31
C. Enforcement.....	31
D. Need to Halt or Reduce Activity Not a Defense.....	31
E. Duty to Mitigate .....	32
F. Duty to Provide Information.....	32
G. Other Information .....	32
H. Signatory Requirements.....	32
I. Property Rights.....	34
J. Severability.....	34
K. Requirement to Obtain Coverage Under an Alternative Permit.....	34
L. Proper Operation and Maintenance .....	35
M. Inspection and Entry .....	35
N. Permit Actions .....	36
O. Definitions .....	36
P. Re-Opener Clause .....	36

Q. Penalties for Falsification of Forms and Reports.....	36
R. Other Permits.....	36
APPENDIX A.....	37
APPENDIX B.....	44
APPENDIX C.....	46
APPENDIX D.....	52
APPENDIX E.....	53
APPENDIX F.....	55

---

(Part I)

## Part I. PERMIT COVERAGE AND LIMITATIONS

### A. Permit Application

This permit authorizes stormwater *discharges to surface waters of the State* from the following *construction activities* identified within 40 CFR Parts 122.26(b)(14)(x), 122.26(b)(15)(i) and 122.26(b)(15)(ii), provided all of the eligibility provisions of this permit are met:

1. *Construction activities* involving soil disturbances of one (1) or more acres; including disturbances of less than one acre that are part of a *larger common plan of development or sale* that will ultimately disturb one or more acres of land; excluding *routine maintenance activity* that is performed to maintain the original line and grade, hydraulic capacity or original purpose of a facility;
2. *Construction activities* involving soil disturbances of less than one (1) acre where the Department has determined that a *SPDES* permit is required for stormwater *discharges* based on the potential for contribution to a violation of a *water quality standard* or for significant contribution of *pollutants* to *surface waters of the State*.
3. *Construction activities* located in the watershed(s) identified in Appendix D that involve soil disturbances between five thousand (5,000) square feet and one (1) acre of land.

### B. Effluent Limitations Applicable to Discharges from Construction Activities

*Discharges* authorized by this permit must achieve, at a minimum, the effluent limitations in Part I.B.1. (a) – (f) of this permit. These limitations represent the degree of effluent reduction attainable by the application of best practicable technology currently available.

1. Erosion and Sediment Control Requirements - The *owner or operator* must select, design, install, implement and maintain control measures to *minimize* the *discharge of pollutants* and prevent a violation of the *water quality standards*. The selection, design, installation, implementation, and maintenance of these control measures must meet the non-numeric effluent limitations in Part I.B.1.(a) – (f) of this permit and be in accordance with the New York State Standards and Specifications for Erosion and Sediment Control, dated November 2016, using sound engineering judgment. Where control measures are not designed in conformance with the design criteria included in the technical standard, the *owner or operator* must include in the Stormwater Pollution Prevention Plan (“SWPPP”) the reason(s) for the deviation or alternative design and provide information

(Part I.B.1)

which demonstrates that the deviation or alternative design is *equivalent* to the technical standard.

a. **Erosion and Sediment Controls.** Design, install and maintain effective erosion and sediment controls to *minimize* the *discharge* of *pollutants* and prevent a violation of the *water quality standards*. At a minimum, such controls must be designed, installed and maintained to:

- (i) *Minimize* soil erosion through application of runoff control and soil stabilization control measure to *minimize pollutant discharges*;
- (ii) Control stormwater *discharges* to *minimize* channel and streambank erosion and scour in the immediate vicinity of the *discharge* points;
- (iii) *Minimize* the amount of soil exposed during *construction activity*;
- (iv) *Minimize* the disturbance of *steep slopes*;
- (v) *Minimize* sediment *discharges* from the site;
- (vi) Provide and maintain natural buffers around surface waters, direct stormwater to vegetated areas and maximize stormwater infiltration to reduce *pollutant discharges*, unless *infeasible*;
- (vii) *Minimize* soil compaction. Minimizing soil compaction is not required where the intended function of a specific area of the site dictates that it be compacted; and
- (viii) Unless *infeasible*, preserve a sufficient amount of topsoil to complete soil restoration and establish a uniform, dense vegetative cover.

b. **Soil Stabilization.** In areas where soil disturbance activity has temporarily or permanently ceased, the application of soil stabilization measures must be initiated by the end of the next business day and completed within fourteen (14) days from the date the current soil disturbance activity ceased. For construction sites that *directly discharge* to one of the 303(d) segments listed in Appendix E or is located in one of the watersheds listed in Appendix C, the application of soil stabilization measures must be initiated by the end of the next business day and completed within seven (7) days from the date the current soil disturbance activity ceased. See Appendix A for definition of *Temporarily Ceased*.

c. **Dewatering.** *Discharges* from dewatering activities, including *discharges*

(Part I.B.1.c)

from dewatering of trenches and excavations, must be managed by appropriate control measures.

d. **Pollution Prevention Measures.** Design, install, implement, and maintain effective pollution prevention measures to *minimize the discharge of pollutants* and prevent a violation of the *water quality standards*. At a minimum, such measures must be designed, installed, implemented and maintained to:

- (i) *Minimize the discharge of pollutants* from equipment and vehicle washing, wheel wash water, and other wash waters. This applies to washing operations that use clean water only. Soaps, detergents and solvents cannot be used;
- (ii) *Minimize the exposure of building materials, building products, construction wastes, trash, landscape materials, fertilizers, pesticides, herbicides, detergents, sanitary waste and other materials present on the site to precipitation and to stormwater.* Minimization of exposure is not required in cases where the exposure to precipitation and to stormwater will not result in a *discharge of pollutants*, or where exposure of a specific material or product poses little risk of stormwater contamination (such as final products and materials intended for outdoor use) ; and
- (iii) Prevent the *discharge of pollutants* from spills and leaks and implement chemical spill and leak prevention and response procedures.

e. **Prohibited Discharges.** The following *discharges* are prohibited:

- (i) Wastewater from washout of concrete;
- (ii) Wastewater from washout and cleanout of stucco, paint, form release oils, curing compounds and other construction materials;
- (iii) Fuels, oils, or other *pollutants* used in vehicle and equipment operation and maintenance;
- (iv) Soaps or solvents used in vehicle and equipment washing; and
- (v) Toxic or hazardous substances from a spill or other release.

f. **Surface Outlets.** When discharging from basins and impoundments, the outlets shall be designed, constructed and maintained in such a manner that sediment does not leave the basin or impoundment and that erosion



(Part I.B.1.f)

at or below the outlet does not occur.

### **C. Post-construction Stormwater Management Practice Requirements**

1. The *owner or operator* of a *construction activity* that requires post-construction stormwater management practices pursuant to Part III.C. of this permit must select, design, install, and maintain the practices to meet the *performance criteria* in the New York State Stormwater Management Design Manual (“Design Manual”), dated January 2015, using sound engineering judgment. Where post-construction stormwater management practices (“SMPs”) are not designed in conformance with the *performance criteria* in the Design Manual, the *owner or operator* must include in the SWPPP the reason(s) for the deviation or alternative design and provide information which demonstrates that the deviation or alternative design is *equivalent* to the technical standard.
2. The *owner or operator* of a *construction activity* that requires post-construction stormwater management practices pursuant to Part III.C. of this permit must design the practices to meet the applicable *sizing criteria* in Part I.C.2.a., b., c. or d. of this permit.

#### **a. Sizing Criteria for New Development**

- (i) Runoff Reduction Volume (“RRv”): Reduce the total Water Quality Volume (“WQv”) by application of RR techniques and standard SMPs with RRv capacity. The total WQv shall be calculated in accordance with the criteria in Section 4.2 of the Design Manual.
- (ii) Minimum RRv and Treatment of Remaining Total WQv: *Construction activities* that cannot meet the criteria in Part I.C.2.a.(i) of this permit due to *site limitations* shall direct runoff from all newly constructed *impervious areas* to a RR technique or standard SMP with RRv capacity unless *infeasible*. The specific *site limitations* that prevent the reduction of 100% of the WQv shall be documented in the SWPPP. For each *impervious area* that is not directed to a RR technique or standard SMP with RRv capacity, the SWPPP must include documentation which demonstrates that all options were considered and for each option explains why it is considered *infeasible*.

**In no case shall the runoff reduction achieved from the newly constructed *impervious areas* be less than the Minimum RRv as calculated using the criteria in Section 4.3 of the Design Manual.** The remaining portion of the total WQv

(Part I.C.2.a.ii)

that cannot be reduced shall be treated by application of standard SMPs.

- (iii) Channel Protection Volume (“Cpv”): Provide 24 hour extended detention of the post-developed 1-year, 24-hour storm event; remaining after runoff reduction. The Cpv requirement does not apply when:
  - (1) Reduction of the entire Cpv is achieved by application of runoff reduction techniques or infiltration systems, or
  - (2) The site *discharges* directly to tidal waters, or fifth order or larger streams.
- (iv) Overbank Flood Control Criteria (“Qp”): Requires storage to attenuate the post-development 10-year, 24-hour peak *discharge* rate (Qp) to predevelopment rates. The Qp requirement does not apply when:
  - (1) the site *discharges* directly to tidal waters or fifth order or larger streams, or
  - (2) A downstream analysis reveals that overbank control is not required.
- (v) Extreme Flood Control Criteria (“Qf”): Requires storage to attenuate the post-development 100-year, 24-hour peak *discharge* rate (Qf) to predevelopment rates. The Qf requirement does not apply when:
  - (1) the site *discharges* directly to tidal waters or fifth order or larger streams, or
  - (2) A downstream analysis reveals that overbank control is not required.

**b. Sizing Criteria for New Development in Enhanced Phosphorus Removal Watershed**

- (i) Runoff Reduction Volume (RRv): Reduce the total Water Quality Volume (WQv) by application of RR techniques and standard SMPs with RRv capacity. The total WQv is the runoff volume from the 1-year, 24 hour design storm over the post-developed watershed and shall be calculated in accordance with the criteria in Section 10.3 of the Design Manual.
- (ii) Minimum RRv and Treatment of Remaining Total WQv: *Construction activities* that cannot meet the criteria in Part I.C.2.b.(i) of this permit due to *site limitations* shall direct runoff from all newly constructed *impervious areas* to a RR technique or

(Part I.C.2.b.ii)

standard SMP with RRv capacity unless *infeasible*. The specific *site limitations* that prevent the reduction of 100% of the WQv shall be documented in the SWPPP. For each *impervious area* that is not directed to a RR technique or standard SMP with RRv capacity, the SWPPP must include documentation which demonstrates that all options were considered and for each option explains why it is considered *infeasible*.

**In no case shall the runoff reduction achieved from the newly constructed *impervious areas* be less than the Minimum RRv as calculated using the criteria in Section 10.3 of the Design Manual.** The remaining portion of the total WQv that cannot be reduced shall be treated by application of standard SMPs.

- (iii) Channel Protection Volume (Cpv): Provide 24 hour extended detention of the post-developed 1-year, 24-hour storm event; remaining after runoff reduction. The Cpv requirement does not apply when:
  - (1) Reduction of the entire Cpv is achieved by application of runoff reduction techniques or infiltration systems, or
  - (2) The site *discharges* directly to tidal waters, or fifth order or larger streams.
- (iv) Overbank Flood Control Criteria (Qp): Requires storage to attenuate the post-development 10-year, 24-hour peak *discharge* rate (Qp) to predevelopment rates. The Qp requirement does not apply when:
  - (1) the site *discharges* directly to tidal waters or fifth order or larger streams, or
  - (2) A downstream analysis reveals that overbank control is not required.
- (v) Extreme Flood Control Criteria (Qf): Requires storage to attenuate the post-development 100-year, 24-hour peak *discharge* rate (Qf) to predevelopment rates. The Qf requirement does not apply when:
  - (1) the site *discharges* directly to tidal waters or fifth order or larger streams, or
  - (2) A downstream analysis reveals that overbank control is not required.

**c. Sizing Criteria for Redevelopment Activity**

(Part I.C.2.c.i)

- (i) Water Quality Volume (WQv): The WQv treatment objective for *redevelopment activity* shall be addressed by one of the following options. *Redevelopment activities* located in an Enhanced Phosphorus Removal Watershed (see Part III.B.3. and Appendix C of this permit) shall calculate the WQv in accordance with Section 10.3 of the Design Manual. All other *redevelopment activities* shall calculate the WQv in accordance with Section 4.2 of the Design Manual.
- (1) Reduce the existing *impervious cover* by a minimum of 25% of the total disturbed, *impervious area*. The Soil Restoration criteria in Section 5.1.6 of the Design Manual must be applied to all newly created pervious areas, or
  - (2) Capture and treat a minimum of 25% of the WQv from the disturbed, *impervious area* by the application of standard SMPs; or reduce 25% of the WQv from the disturbed, *impervious area* by the application of RR techniques or standard SMPs with RRv capacity., or
  - (3) Capture and treat a minimum of 75% of the WQv from the disturbed, *impervious area* as well as any additional runoff from tributary areas by application of the alternative practices discussed in Sections 9.3 and 9.4 of the Design Manual., or
  - (4) Application of a combination of 1, 2 and 3 above that provide a weighted average of at least two of the above methods. Application of this method shall be in accordance with the criteria in Section 9.2.1(B) (IV) of the Design Manual.

If there is an existing post-construction stormwater management practice located on the site that captures and treats runoff from the *impervious area* that is being disturbed, the WQv treatment option selected must, at a minimum, provide treatment equal to the treatment that was being provided by the existing practice(s) if that treatment is greater than the treatment required by options 1 – 4 above.

- (ii) Channel Protection Volume (Cpv): Not required if there are no changes to hydrology that increase the *discharge* rate from the project site.
- (iii) Overbank Flood Control Criteria (Qp): Not required if there are no changes to hydrology that increase the *discharge* rate from the project site.

(Part I.C.2.c.iv)

- (iv) Extreme Flood Control Criteria (Qf): Not required if there are no changes to hydrology that increase the *discharge* rate from the project site.

**d. Sizing Criteria for Combination of Redevelopment Activity and New Development**

Construction projects that include both *New Development* and *Redevelopment Activity* shall provide post-construction stormwater management controls that meet the *sizing criteria* calculated as an aggregate of the *Sizing Criteria* in Part I.C.2.a. or b. of this permit for the *New Development* portion of the project and Part I.C.2.c of this permit for *Redevelopment Activity* portion of the project.

**D. Maintaining Water Quality**

The Department expects that compliance with the conditions of this permit will control *discharges* necessary to meet applicable *water quality standards*. It shall be a violation of the *ECL* for any discharge to either cause or contribute to a violation of *water quality standards* as contained in Parts 700 through 705 of Title 6 of the Official Compilation of Codes, Rules and Regulations of the State of New York, such as:

1. There shall be no increase in turbidity that will cause a substantial visible contrast to natural conditions;
2. There shall be no increase in suspended, colloidal or settleable solids that will cause deposition or impair the waters for their best usages; and
3. There shall be no residue from oil and floating substances, nor visible oil film, nor globules of grease.

If there is evidence indicating that the stormwater *discharges* authorized by this permit are causing, have the reasonable potential to cause, or are contributing to a violation of the *water quality standards*; the *owner or operator* must take appropriate corrective action in accordance with Part IV.C.5. of this general permit and document in accordance with Part IV.C.4. of this general permit. To address the *water quality standard* violation the *owner or operator* may need to provide additional information, include and implement appropriate controls in the SWPPP to correct the problem, or obtain an individual SPDES permit.

If there is evidence indicating that despite compliance with the terms and conditions of this general permit it is demonstrated that the stormwater *discharges* authorized by this permit are causing or contributing to a violation of *water quality standards*, or

(Part I.D)

if the Department determines that a modification of the permit is necessary to prevent a violation of *water quality standards*, the authorized *discharges* will no longer be eligible for coverage under this permit. The Department may require the *owner or operator* to obtain an individual SPDES permit to continue discharging.

#### **E. Eligibility Under This General Permit**

1. This permit may authorize all *discharges* of stormwater from *construction activity to surface waters of the State* and *groundwaters* except for ineligible *discharges* identified under subparagraph F. of this Part.
2. Except for non-stormwater *discharges* explicitly listed in the next paragraph, this permit only authorizes stormwater *discharges* from *construction activities*.
3. Notwithstanding paragraphs E.1 and E.2 above, the following non-stormwater *discharges* may be authorized by this permit: *discharges* from firefighting activities; fire hydrant flushings; waters to which cleansers or other components have not been added that are used to wash vehicles or control dust in accordance with the SWPPP, routine external building washdown which does not use detergents; pavement washwaters where spills or leaks of toxic or hazardous materials have not occurred (unless all spilled material has been removed) and where detergents are not used; air conditioning condensate; uncontaminated *groundwater* or spring water; uncontaminated *discharges* from construction site de-watering operations; and foundation or footing drains where flows are not contaminated with process materials such as solvents. For those entities required to obtain coverage under this permit, and who *discharge* as noted in this paragraph, and with the exception of flows from firefighting activities, these *discharges* must be identified in the SWPPP. Under all circumstances, the *owner or operator* must still comply with *water quality standards* in Part I.D of this permit.
4. The *owner or operator* must maintain permit eligibility to *discharge* under this permit. Any *discharges* that are not compliant with the eligibility conditions of this permit are not authorized by the permit and the *owner or operator* must either apply for a separate permit to cover those ineligible *discharges* or take steps necessary to make the *discharge* eligible for coverage.

#### **F. Activities Which Are Ineligible for Coverage Under This General Permit**

All of the following are **not** authorized by this permit:

(Part I.F)

1. *Discharges after construction activities* have been completed and the site has undergone *final stabilization*;
2. *Discharges* that are mixed with sources of non-stormwater other than those expressly authorized under subsection E.3. of this Part and identified in the SWPPP required by this permit;
3. *Discharges* that are required to obtain an individual SPDES permit or another SPDES general permit pursuant to Part VII.K. of this permit;
4. *Construction activities* or *discharges from construction activities* that may adversely affect an endangered or threatened species unless the *owner or operator* has obtained a permit issued pursuant to 6 NYCRR Part 182 for the project or the Department has issued a letter of non-jurisdiction for the project. All documentation necessary to demonstrate eligibility shall be maintained on site in accordance with Part II.C.2 of this permit.
5. *Discharges* which either cause or contribute to a violation of *water quality standards* adopted pursuant to the *ECL* and its accompanying regulations;
6. *Construction activities* for residential, commercial and institutional projects:
  - a. Where the *discharges* from the *construction activities* are tributary to waters of the state classified as AA or AA-s; and
  - b. Which disturb one or more acres of land with no existing *impervious cover*; and
  - c. Which are undertaken on land with a Soil Slope Phase that is identified as an E or F, or the map unit name is inclusive of 25% or greater slope, on the United States Department of Agriculture (“USDA”) Soil Survey for the County where the disturbance will occur.
7. *Construction activities* for linear transportation projects and linear utility projects:
  - a. Where the *discharges* from the *construction activities* are tributary to waters of the state classified as AA or AA-s; and
  - b. Which disturb two or more acres of land with no existing *impervious cover*; and
  - c. Which are undertaken on land with a Soil Slope Phase that is identified as an E or F, or the map unit name is inclusive of 25% or greater slope, on the USDA Soil Survey for the County where the disturbance will occur.

(Part I.F.8)

8. *Construction activities* that have the potential to affect an *historic property*, unless there is documentation that such impacts have been resolved. The following documentation necessary to demonstrate eligibility with this requirement shall be maintained on site in accordance with Part II.C.2 of this permit and made available to the Department in accordance with Part VII.F of this permit:
- a. Documentation that the *construction activity* is not within an archeologically sensitive area indicated on the sensitivity map, and that the *construction activity* is not located on or immediately adjacent to a property listed or determined to be eligible for listing on the National or State Registers of Historic Places, and that there is no new permanent building on the construction site within the following distances from a building, structure, or object that is more than 50 years old, or if there is such a new permanent building on the construction site within those parameters that NYS Office of Parks, Recreation and Historic Preservation (OPRHP), a Historic Preservation Commission of a Certified Local Government, or a qualified preservation professional has determined that the building, structure, or object more than 50 years old is not historically/archeologically significant.
    - 1-5 acres of disturbance - 20 feet
    - 5-20 acres of disturbance - 50 feet
    - 20+ acres of disturbance - 100 feet, or
  - b. DEC consultation form sent to OPRHP, and copied to the NYS DEC Agency Historic Preservation Officer (APO), and
    - (i) the State Environmental Quality Review (SEQR) Environmental Assessment Form (EAF) with a negative declaration or the Findings Statement, with documentation of OPRHP's agreement with the resolution; or
    - (ii) documentation from OPRHP that the *construction activity* will result in No Impact; or
    - (iii) documentation from OPRHP providing a determination of No Adverse Impact; or
    - (iv) a Letter of Resolution signed by the owner/operator, OPRHP and the DEC APO which allows for this *construction activity* to be eligible for coverage under the general permit in terms of the State Historic Preservation Act (SHPA); or
  - c. Documentation of satisfactory compliance with Section 106 of the National Historic Preservation Act for a coterminous project area:
    - (i) No Affect
    - (ii) No Adverse Affect



(Part I.F.8.c.iii)

(iii) Executed Memorandum of Agreement, or

d. Documentation that:

(i) SHPA Section 14.09 has been completed by NYS DEC or another state agency.

9. *Discharges from construction activities* that are subject to an existing SPDES individual or general permit where a SPDES permit for *construction activity* has been terminated or denied; or where the *owner or operator* has failed to renew an expired individual permit.

## Part II. OBTAINING PERMIT COVERAGE

### A. Notice of Intent (NOI) Submittal

1. An *owner or operator* of a *construction activity* that is not subject to the requirements of a *regulated, traditional land use control MS4* must first prepare a SWPPP in accordance with all applicable requirements of this permit and then submit a completed NOI form to the Department in order to be authorized to *discharge* under this permit. An *owner or operator* shall use either the electronic (eNOI) or paper version of the NOI that the Department prepared. Both versions of the NOI are located on the Department's website (<http://www.dec.ny.gov/>). The paper version of the NOI shall be signed in accordance with Part VII.H. of this permit and submitted to the following address.

**NOTICE OF INTENT  
NYS DEC, Bureau of Water Permits  
625 Broadway, 4<sup>th</sup> Floor  
Albany, New York 12233-3505**

2. An *owner or operator* of a *construction activity* that is subject to the requirements of a *regulated, traditional land use control MS4* must first prepare a SWPPP in accordance with all applicable requirements of this permit and then have its SWPPP reviewed and accepted by the *regulated, traditional land use control MS4* prior to submitting the NOI to the Department. The *owner or operator* shall have the "MS4 SWPPP Acceptance" form signed in accordance with Part VII.H., and then submit that form along with a completed NOI to the Department. An *owner or operator* shall use either the electronic (eNOI) or paper version of the NOI.

The paper version of the NOI shall be signed in accordance with Part VII.H. of this permit and submitted to the address in Part II.A.1.

(Part II.A.2)

The requirement for an *owner or operator* to have its SWPPP reviewed and accepted by the *MS4* prior to submitting the NOI to the Department does not apply to an *owner or operator* that is obtaining permit coverage in accordance with the requirements in Part II.E. (Change of *Owner or Operator*) or where the *owner or operator* of the *construction activity* is the *regulated, traditional land use control MS4*.

3. The *owner or operator* shall have the SWPPP preparer sign the “SWPPP Preparer Certification” statement on the NOI prior to submitting the form to the Department.
4. As of the date the NOI is submitted to the Department, the *owner or operator* shall make the NOI and SWPPP available for review and copying in accordance with the requirements in Part VII.F. of this permit.

**B. Permit Authorization**

1. An *owner or operator* shall not *commence construction activity* until their authorization to *discharge* under this permit goes into effect.
2. Authorization to *discharge* under this permit will be effective when the *owner or operator* has satisfied all of the following criteria:
  - a. project review pursuant to the State Environmental Quality Review Act (“SEQRA”) have been satisfied, when SEQRA is applicable. See the Department’s website (<http://www.dec.ny.gov/>) for more information,
  - b. where required, all necessary Department permits subject to the *Uniform Procedures Act (“UPA”)* (see 6 NYCRR Part 621) have been obtained, unless otherwise notified by the Department pursuant to 6 NYCRR 621.3(a)(4). *Owners or operators of construction activities* that are required to obtain *UPA* permits must submit a preliminary SWPPP to the appropriate DEC Permit Administrator at the Regional Office listed in Appendix F at the time all other necessary *UPA* permit applications are submitted. The preliminary SWPPP must include sufficient information to demonstrate that the *construction activity* qualifies for authorization under this permit,
  - c. the final SWPPP has been prepared, and
  - d. a complete NOI has been submitted to the Department in accordance with the requirements of this permit.
3. An *owner or operator* that has satisfied the requirements of Part II.B.2 above

(Part II.B.3)

will be authorized to *discharge* stormwater from their *construction activity* in accordance with the following schedule:

- a. For *construction activities* that are not subject to the requirements of a *regulated, traditional land use control MS4*:
  - (i) Five (5) business days from the date the Department receives a complete electronic version of the NOI (eNOI) for *construction activities* with a SWPPP that has been prepared in conformance with the design criteria in the technical standard referenced in Part III.B.1 and the *performance criteria* in the technical standard referenced in Parts III.B., 2 or 3, for *construction activities* that require post-construction stormwater management practices pursuant to Part III.C.; or
  - (ii) Sixty (60) business days from the date the Department receives a complete NOI (electronic or paper version) for *construction activities* with a SWPPP that has not been prepared in conformance with the design criteria in technical standard referenced in Part III.B.1. or, for *construction activities* that require post-construction stormwater management practices pursuant to Part III.C., the *performance criteria* in the technical standard referenced in Parts III.B., 2 or 3, or;
  - (iii) Ten (10) business days from the date the Department receives a complete paper version of the NOI for *construction activities* with a SWPPP that has been prepared in conformance with the design criteria in the technical standard referenced in Part III.B.1 and the *performance criteria* in the technical standard referenced in Parts III.B., 2 or 3, for *construction activities* that require post-construction stormwater management practices pursuant to Part III.C.
- b. For *construction activities* that are subject to the requirements of a *regulated, traditional land use control MS4*:
  - (i) Five (5) business days from the date the Department receives both a complete electronic version of the NOI (eNOI) and signed “MS4 SWPPP Acceptance” form, or
  - (ii) Ten (10) business days from the date the Department receives both a complete paper version of the NOI and signed “MS4 SWPPP Acceptance” form.

4. The Department may suspend or deny an *owner’s or operator’s* coverage

(Part II.B.4)

under this permit if the Department determines that the SWPPP does not meet the permit requirements. In accordance with statute, regulation, and the terms and conditions of this permit, the Department may deny coverage under this permit and require submittal of an application for an individual SPDES permit based on a review of the NOI or other information pursuant to Part II.

5. Coverage under this permit authorizes stormwater *discharges* from only those areas of disturbance that are identified in the NOI. If an *owner or operator* wishes to have stormwater *discharges* from future or additional areas of disturbance authorized, they must submit a new NOI that addresses that phase of the development, unless otherwise notified by the Department. The *owner or operator* shall not *commence construction activity* on the future or additional areas until their authorization to *discharge* under this permit goes into effect in accordance with Part II.B. of this permit.

### **C. General Requirements For Owners or Operators With Permit Coverage**

1. The *owner or operator* shall ensure that the provisions of the SWPPP are implemented from the *commencement of construction activity* until all areas of disturbance have achieved *final stabilization* and the Notice of Termination (“NOT”) has been submitted to the Department in accordance with Part V. of this permit. This includes any changes made to the SWPPP pursuant to Part III.A.4. of this permit.
2. The *owner or operator* shall maintain a copy of the General Permit (GP-0-15-002), NOI, *NOI Acknowledgment Letter*, SWPPP, MS4 SWPPP Acceptance form, inspection reports, and all documentation necessary to demonstrate eligibility with this permit at the construction site until all disturbed areas have achieved *final stabilization* and the NOT has been submitted to the Department. The documents must be maintained in a secure location, such as a job trailer, on-site construction office, or mailbox with lock. The secure location must be accessible during normal business hours to an individual performing a compliance inspection.
3. The *owner or operator* of a *construction activity* shall not disturb greater than five (5) acres of soil at any one time without prior written authorization from the Department or, in areas under the jurisdiction of a *regulated, traditional land use control MS4*, the *regulated, traditional land use control MS4* (provided the *regulated, traditional land use control MS4* is not the *owner or operator* of the *construction activity*). At a minimum, the *owner or operator* must comply with the following requirements in order to be authorized to disturb greater than five (5) acres of soil at any one time:
  - a. The *owner or operator* shall

(Part II.C.3.a)

have a *qualified inspector* conduct **at least** two (2) site inspections in accordance with Part IV.C. of this permit every seven (7) calendar days, for as long as greater than five (5) acres of soil remain disturbed. The two (2) inspections shall be separated by a minimum of two (2) full calendar days.

- b. In areas where soil disturbance activity has temporarily or permanently ceased, the application of soil stabilization measures must be initiated by the end of the next business day and completed within seven (7) days from the date the current soil disturbance activity ceased. The soil stabilization measures selected shall be in conformance with the technical standard, New York State Standards and Specifications for Erosion and Sediment Control, dated November 2016.
  - c. The *owner or operator* shall prepare a phasing plan that defines maximum disturbed area per phase and shows required cuts and fills.
  - d. The *owner or operator* shall install any additional site specific practices needed to protect water quality.
  - e. The *owner or operator* shall include the requirements above in their SWPPP.
4. In accordance with statute, regulations, and the terms and conditions of this permit, the Department may suspend or revoke an *owner's or operator's* coverage under this permit at any time if the Department determines that the SWPPP does not meet the permit requirements. Upon a finding of significant non-compliance with the practices described in the SWPPP or violation of this permit, the Department may order an immediate stop to all activity at the site until the non-compliance is remedied. The stop work order shall be in writing, describe the non-compliance in detail, and be sent to the *owner or operator*.
5. For *construction activities* that are subject to the requirements of a *regulated, traditional land use control MS4*, the *owner or operator* shall notify the *regulated, traditional land use control MS4* in writing of any planned amendments or modifications to the post-construction stormwater management practice component of the SWPPP required by Part III.A. 4. and 5. of this permit. Unless otherwise notified by the *regulated, traditional land use control MS4*, the *owner or operator* shall have the SWPPP amendments or modifications reviewed and accepted by the *regulated, traditional land use control MS4* prior to commencing construction of the post-construction stormwater management practice

(Part II.D)

#### **D. Permit Coverage for Discharges Authorized Under GP-0-10-001**

1. Upon renewal of SPDES General Permit for Stormwater Discharges from *Construction Activity* (Permit No. GP-0-10-001), an *owner or operator* of a *construction activity* with coverage under GP-0-10-001, as of the effective date of GP-0-15-002, shall be authorized to *discharge* in accordance with GP-0-15-002, unless otherwise notified by the Department.

An *owner or operator* may continue to implement the technical/design components of the post-construction stormwater management controls provided that such design was done in conformance with the technical standards in place at the time of initial project authorization. However, they must comply with the other, non-design provisions of GP-0-15-002.

#### **E. Change of *Owner or Operator***

1. When property ownership changes or when there is a change in operational control over the construction plans and specifications, the original *owner or operator* must notify the new *owner or operator*, in writing, of the requirement to obtain permit coverage by submitting a NOI with the Department. Once the new *owner or operator* obtains permit coverage, the original *owner or operator* shall then submit a completed NOT with the name and permit identification number of the new *owner or operator* to the Department at the address in Part II.A.1. of this permit. If the original *owner or operator* maintains ownership of a portion of the *construction activity* and will disturb soil, they must maintain their coverage under the permit.

Permit coverage for the new *owner or operator* will be effective as of the date the Department receives a complete NOI, provided the original *owner or operator* was not subject to a sixty (60) business day authorization period that has not expired as of the date the Department receives the NOI from the new *owner or operator*.

(Part III)

## Part III. STORMWATER POLLUTION PREVENTION PLAN (SWPPP)

### A. General SWPPP Requirements

1. A SWPPP shall be prepared and implemented by the *owner or operator* of each *construction activity* covered by this permit. The SWPPP must document the selection, design, installation, implementation and maintenance of the control measures and practices that will be used to meet the effluent limitations in Part I.B. of this permit and where applicable, the post-construction stormwater management practice requirements in Part I.C. of this permit. The SWPPP shall be prepared prior to the submittal of the NOI. The NOI shall be submitted to the Department prior to the *commencement of construction activity*. A copy of the completed, final NOI shall be included in the SWPPP.
2. The SWPPP shall describe the erosion and sediment control practices and where required, post-construction stormwater management practices that will be used and/or constructed to reduce the *pollutants* in stormwater *discharges* and to assure compliance with the terms and conditions of this permit. In addition, the SWPPP shall identify potential sources of pollution which may reasonably be expected to affect the quality of stormwater *discharges*.
3. All SWPPPs that require the post-construction stormwater management practice component shall be prepared by a *qualified professional* that is knowledgeable in the principles and practices of stormwater management and treatment.
4. The *owner or operator* must keep the SWPPP current so that it at all times accurately documents the erosion and sediment controls practices that are being used or will be used during construction, and all post-construction stormwater management practices that will be constructed on the site. At a minimum, the *owner or operator* shall amend the SWPPP:
  - a. whenever the current provisions prove to be ineffective in minimizing *pollutants* in stormwater *discharges* from the site;
  - b. whenever there is a change in design, construction, or operation at the construction site that has or could have an effect on the *discharge* of *pollutants*; and
  - c. to address issues or deficiencies identified during an inspection by the *qualified inspector*, the Department or other regulatory authority.
5. The Department may notify the *owner or operator* at any time that the

(Part III.A.5)

SWPPP does not meet one or more of the minimum requirements of this permit. The notification shall be in writing and identify the provisions of the SWPPP that require modification. Within fourteen (14) calendar days of such notification, or as otherwise indicated by the Department, the *owner or operator* shall make the required changes to the SWPPP and submit written notification to the Department that the changes have been made. If the *owner or operator* does not respond to the Department's comments in the specified time frame, the Department may suspend the *owner's or operator's* coverage under this permit or require the *owner or operator* to obtain coverage under an individual SPDES permit in accordance with Part II.C.4. of this permit.

6. Prior to the *commencement of construction activity*, the *owner or operator* must identify the contractor(s) and subcontractor(s) that will be responsible for installing, constructing, repairing, replacing, inspecting and maintaining the erosion and sediment control practices included in the SWPPP; and the contractor(s) and subcontractor(s) that will be responsible for constructing the post-construction stormwater management practices included in the SWPPP. The *owner or operator* shall have each of the contractors and subcontractors identify at least one person from their company that will be responsible for implementation of the SWPPP. This person shall be known as the *trained contractor*. The *owner or operator* shall ensure that at least one *trained contractor* is on site on a daily basis when soil disturbance activities are being performed.

The *owner or operator* shall have each of the contractors and subcontractors identified above sign a copy of the following certification statement below before they commence any *construction activity*:

"I hereby certify under penalty of law that I understand and agree to comply with the terms and conditions of the SWPPP and agree to implement any corrective actions identified by the *qualified inspector* during a site inspection. I also understand that the *owner or operator* must comply with the terms and conditions of the most current version of the New York State Pollutant Discharge Elimination System ("SPDES") general permit for stormwater *discharges* from *construction activities* and that it is unlawful for any person to cause or contribute to a violation of *water quality standards*. Furthermore, I am aware that there are significant penalties for submitting false information, that I do not believe to be true, including the possibility of fine and imprisonment for knowing violations"

In addition to providing the certification statement above, the certification page must also identify the specific elements of the SWPPP that each contractor and subcontractor will be responsible for and include the name and title of the person providing the signature; the name and title of the



(Part III.A.6)

*trained contractor* responsible for SWPPP implementation; the name, address and telephone number of the contracting firm; the address (or other identifying description) of the site; and the date the certification statement is signed. The *owner or operator* shall attach the certification statement(s) to the copy of the SWPPP that is maintained at the construction site. If new or additional contractors are hired to implement measures identified in the SWPPP after construction has commenced, they must also sign the certification statement and provide the information listed above.

7. For projects where the Department requests a copy of the SWPPP or inspection reports, the *owner or operator* shall submit the documents in both electronic (PDF only) and paper format within five (5) business days, unless otherwise notified by the Department.

**B. Required SWPPP Contents**

1. Erosion and sediment control component - All SWPPPs prepared pursuant to this permit shall include erosion and sediment control practices designed in conformance with the technical standard, New York State Standards and Specifications for Erosion and Sediment Control, dated November 2016. Where erosion and sediment control practices are not designed in conformance with the design criteria included in the technical standard, the *owner or operator* must demonstrate *equivalence* to the technical standard. At a minimum, the erosion and sediment control component of the SWPPP shall include the following:
  - a. Background information about the scope of the project, including the location, type and size of project;
  - b. A site map/construction drawing(s) for the project, including a general location map. At a minimum, the site map shall show the total site area; all improvements; areas of disturbance; areas that will not be disturbed; existing vegetation; on-site and adjacent off-site surface water(s); floodplain/floodway boundaries; wetlands and drainage patterns that could be affected by the *construction activity*; existing and final contours ; locations of different soil types with boundaries; material, waste, borrow or equipment storage areas located on adjacent properties; and location(s) of the stormwater *discharge(s)*;
  - c. A description of the soil(s) present at the site, including an identification of the Hydrologic Soil Group (HSG);
  - d. A construction phasing plan and sequence of operations describing the intended order of *construction activities*, including clearing and grubbing, excavation and grading, utility and infrastructure installation and any other

(Part III.B.1.d)

activity at the site that results in soil disturbance;

- e. A description of the minimum erosion and sediment control practices to be installed or implemented for each *construction activity* that will result in soil disturbance. Include a schedule that identifies the timing of initial placement or implementation of each erosion and sediment control practice and the minimum time frames that each practice should remain in place or be implemented;
- f. A temporary and permanent soil stabilization plan that meets the requirements of this general permit and the technical standard, New York State Standards and Specifications for Erosion and Sediment Control, dated November 2016, for each stage of the project, including initial land clearing and grubbing to project completion and achievement of *final stabilization*;
- g. A site map/construction drawing(s) showing the specific location(s), size(s), and length(s) of each erosion and sediment control practice;
- h. The dimensions, material specifications, installation details, and operation and maintenance requirements for all erosion and sediment control practices. Include the location and sizing of any temporary sediment basins and structural practices that will be used to divert flows from exposed soils;
- i. A maintenance inspection schedule for the contractor(s) identified in Part III.A.6. of this permit, to ensure continuous and effective operation of the erosion and sediment control practices. The maintenance inspection schedule shall be in accordance with the requirements in the technical standard, New York State Standards and Specifications for Erosion and Sediment Control, dated November 2016;
- j. A description of the pollution prevention measures that will be used to control litter, construction chemicals and construction debris from becoming a *pollutant* source in the stormwater *discharges*;
- k. A description and location of any stormwater *discharges* associated with industrial activity other than construction at the site, including, but not limited to, stormwater *discharges* from asphalt plants and concrete plants located on the construction site; and
- l. Identification of any elements of the design that are not in conformance with the design criteria in the technical standard, New York State Standards and Specifications for Erosion and Sediment Control, dated November 2016. Include the reason for the deviation or alternative design

(Part III.B.1.I)

and provide information which demonstrates that the deviation or alternative design is *equivalent* to the technical standard.

2. Post-construction stormwater management practice component – The *owner or operator* of any construction project identified in Table 2 of Appendix B as needing post-construction stormwater management practices shall prepare a SWPPP that includes practices designed in conformance with the applicable *sizing criteria* in Part I.C.2.a., c. or d. of this permit and the *performance criteria* in the technical standard, New York State Stormwater Management Design Manual dated January 2015

Where post-construction stormwater management practices are not designed in conformance with the *performance criteria* in the technical standard, the *owner or operator* must include in the SWPPP the reason(s) for the deviation or alternative design and provide information which demonstrates that the deviation or alternative design is *equivalent* to the technical standard.

The post-construction stormwater management practice component of the SWPPP shall include the following:

- a. Identification of all post-construction stormwater management practices to be constructed as part of the project. Include the dimensions, material specifications and installation details for each post-construction stormwater management practice;
- b. A site map/construction drawing(s) showing the specific location and size of each post-construction stormwater management practice;
- c. A Stormwater Modeling and Analysis Report that includes:
  - (i) Map(s) showing pre-development conditions, including watershed/subcatchments boundaries, flow paths/routing, and design points;
  - (ii) Map(s) showing post-development conditions, including watershed/subcatchments boundaries, flow paths/routing, design points and post-construction stormwater management practices;
  - (iii) Results of stormwater modeling (i.e. hydrology and hydraulic analysis) for the required storm events. Include supporting calculations (model runs), methodology, and a summary table that compares pre and post-development runoff rates and volumes for the different storm events;
  - (iv) Summary table, with supporting calculations, which demonstrates

(Part III.B.2.c.iv)

that each post-construction stormwater management practice has been designed in conformance with the *sizing criteria* included in the Design Manual;

- (v) Identification of any *sizing criteria* that is not required based on the requirements included in Part I.C. of this permit; and
  - (vi) Identification of any elements of the design that are not in conformance with the *performance criteria* in the Design Manual. Include the reason(s) for the deviation or alternative design and provide information which demonstrates that the deviation or alternative design is *equivalent* to the Design Manual;
- d. Soil testing results and locations (test pits, borings);
  - e. Infiltration test results, when required; and
  - f. An operations and maintenance plan that includes inspection and maintenance schedules and actions to ensure continuous and effective operation of each post-construction stormwater management practice. The plan shall identify the entity that will be responsible for the long term operation and maintenance of each practice.
3. Enhanced Phosphorus Removal Standards - All construction projects identified in Table 2 of Appendix B that are located in the watersheds identified in Appendix C shall prepare a SWPPP that includes post-construction stormwater management practices designed in conformance with the applicable *sizing criteria* in Part I.C.2. b., c. or d. of this permit and the *performance criteria*, Enhanced Phosphorus Removal Standards included in the Design Manual. At a minimum, the post-construction stormwater management practice component of the SWPPP shall include items 2.a - 2.f. above.

### **C. Required SWPPP Components by Project Type**

Unless otherwise notified by the Department, *owners or operators of construction activities* identified in Table 1 of Appendix B are required to prepare a SWPPP that only includes erosion and sediment control practices designed in conformance with Part III.B.1 of this permit. *Owners or operators of the construction activities* identified in Table 2 of Appendix B shall prepare a SWPPP that also includes post-construction stormwater management practices designed in conformance with Part III.B.2 or 3 of this permit.

(Part IV)

## **Part IV. INSPECTION AND MAINTENANCE REQUIREMENTS**

### **A. General Construction Site Inspection and Maintenance Requirements**

1. The *owner or operator* must ensure that all erosion and sediment control practices (including pollution prevention measures) and all post-construction stormwater management practices identified in the SWPPP are inspected and maintained in accordance with Part IV.B. and C. of this permit.
2. The terms of this permit shall not be construed to prohibit the State of New York from exercising any authority pursuant to the ECL, common law or federal law, or prohibit New York State from taking any measures, whether civil or criminal, to prevent violations of the laws of the State of New York, or protect the public health and safety and/or the environment.

### **B. Contractor Maintenance Inspection Requirements**

1. The *owner or operator* of each *construction activity* identified in Tables 1 and 2 of Appendix B shall have a *trained contractor* inspect the erosion and sediment control practices and pollution prevention measures being implemented within the active work area daily to ensure that they are being maintained in effective operating condition at all times. If deficiencies are identified, the contractor shall begin implementing corrective actions within one business day and shall complete the corrective actions in a reasonable time frame.
2. For construction sites where soil disturbance activities have been temporarily suspended (e.g. winter shutdown) and *temporary stabilization* measures have been applied to all disturbed areas, the *trained contractor* can stop conducting the maintenance inspections. The *trained contractor* shall begin conducting the maintenance inspections in accordance with Part IV.B.1. of this permit as soon as soil disturbance activities resume.
3. For construction sites where soil disturbance activities have been shut down with partial project completion, the *trained contractor* can stop conducting the maintenance inspections if all areas disturbed as of the project shutdown date have achieved *final stabilization* and all post-construction stormwater management practices required for the completed portion of the project have been constructed in conformance with the SWPPP and are operational.

### **C. Qualified Inspector Inspection Requirements**

(Part IV.C)

The *owner or operator* shall have a *qualified inspector* conduct site inspections in conformance with the following requirements:

[Note: The *trained contractor* identified in Part III.A.6. and IV.B. of this permit **cannot** conduct the *qualified inspector* site inspections unless they meet the *qualified inspector* qualifications included in Appendix A. In order to perform these inspections, the *trained contractor* would have to be a:

- licensed Professional Engineer,
- Certified Professional in Erosion and Sediment Control (CPESC),
- Registered Landscape Architect, or
- someone working under the direct supervision of, and at the same company as, the licensed Professional Engineer or Registered Landscape Architect, provided they have received four (4) hours of Department endorsed training in proper erosion and sediment control principles from a Soil and Water Conservation District, or other Department endorsed entity].

1. A *qualified inspector* shall conduct site inspections for all *construction activities* identified in Tables 1 and 2 of Appendix B, with the exception of:
  - a. the construction of a single family residential subdivision with 25% or less *impervious cover* at total site build-out that involves a soil disturbance of one (1) or more acres of land but less than five (5) acres and is not located in one of the watersheds listed in Appendix C and not directly discharging to one of the 303(d) segments listed in Appendix E;
  - b. the construction of a single family home that involves a soil disturbance of one (1) or more acres of land but less than five (5) acres and is not located in one of the watersheds listed in Appendix C and not directly discharging to one of the 303(d) segments listed in Appendix E;
  - c. construction on agricultural property that involves a soil disturbance of one (1) or more acres of land but less than five (5) acres; and
  - d. *construction activities* located in the watersheds identified in Appendix D that involve soil disturbances between five thousand (5,000) square feet and one (1) acre of land.
2. Unless otherwise notified by the Department, the *qualified inspector* shall conduct site inspections in accordance with the following timetable:
  - a. For construction sites where soil disturbance activities are on-going, the *qualified inspector* shall conduct a site inspection at least once every seven (7) calendar days.
  - b. For construction sites where soil disturbance activities are on-going and

(Part IV.C.2.b)

the *owner or operator* has received authorization in accordance with Part II.C.3 to disturb greater than five (5) acres of soil at any one time, the *qualified inspector* shall conduct at least two (2) site inspections every seven (7) calendar days. The two (2) inspections shall be separated by a minimum of two (2) full calendar days.

- c. For construction sites where soil disturbance activities have been temporarily suspended (e.g. winter shutdown) and *temporary stabilization* measures have been applied to all disturbed areas, the *qualified inspector* shall conduct a site inspection at least once every thirty (30) calendar days. The *owner or operator* shall notify the DOW Water (SPDES) Program contact at the Regional Office (see contact information in Appendix F) or, in areas under the jurisdiction of a *regulated, traditional land use control MS4*, the *regulated, traditional land use control MS4* (provided the *regulated, traditional land use control MS4* is not the *owner or operator* of the *construction activity*) in writing prior to reducing the frequency of inspections.
- d. For construction sites where soil disturbance activities have been shut down with partial project completion, the *qualified inspector* can stop conducting inspections if all areas disturbed as of the project shutdown date have achieved *final stabilization* and all post-construction stormwater management practices required for the completed portion of the project have been constructed in conformance with the SWPPP and are operational. The *owner or operator* shall notify the DOW Water (SPDES) Program contact at the Regional Office (see contact information in Appendix F) or, in areas under the jurisdiction of a *regulated, traditional land use control MS4*, the *regulated, traditional land use control MS4* (provided the *regulated, traditional land use control MS4* is not the *owner or operator* of the *construction activity*) in writing prior to the shutdown. If soil disturbance activities are not resumed within 2 years from the date of shutdown, the *owner or operator* shall have the *qualified inspector* perform a final inspection and certify that all disturbed areas have achieved *final stabilization*, and all temporary, structural erosion and sediment control measures have been removed; and that all post-construction stormwater management practices have been constructed in conformance with the SWPPP by signing the “*Final Stabilization*” and “*Post-Construction Stormwater Management Practice*” certification statements on the NOT. The *owner or operator* shall then submit the completed NOT form to the address in Part II.A.1 of this permit.
- e. For construction sites that directly *discharge* to one of the 303(d) segments listed in Appendix E or is located in one of the watersheds listed in Appendix C, the *qualified inspector* shall conduct at least two (2) site inspections every seven (7) calendar days. The two (2) inspections shall

(Part IV.C.2.e)

be separated by a minimum of two (2) full calendar days.

3. At a minimum, the *qualified inspector* shall inspect all erosion and sediment control practices and pollution prevention measures to ensure integrity and effectiveness, all post-construction stormwater management practices under construction to ensure that they are constructed in conformance with the SWPPP, all areas of disturbance that have not achieved *final stabilization*, all points of *discharge* to natural surface waterbodies located within, or immediately adjacent to, the property boundaries of the construction site, and all points of *discharge* from the construction site.
4. The *qualified inspector* shall prepare an inspection report subsequent to each and every inspection. At a minimum, the inspection report shall include and/or address the following:
  - a. Date and time of inspection;
  - b. Name and title of person(s) performing inspection;
  - c. A description of the weather and soil conditions (e.g. dry, wet, saturated) at the time of the inspection;
  - d. A description of the condition of the runoff at all points of *discharge* from the construction site. This shall include identification of any *discharges* of sediment from the construction site. Include *discharges* from conveyance systems (i.e. pipes, culverts, ditches, etc.) and overland flow;
  - e. A description of the condition of all natural surface waterbodies located within, or immediately adjacent to, the property boundaries of the construction site which receive runoff from disturbed areas. This shall include identification of any *discharges* of sediment to the surface waterbody;
  - f. Identification of all erosion and sediment control practices and pollution prevention measures that need repair or maintenance;
  - g. Identification of all erosion and sediment control practices and pollution prevention measures that were not installed properly or are not functioning as designed and need to be reinstalled or replaced;
  - h. Description and sketch of areas with active soil disturbance activity, areas that have been disturbed but are inactive at the time of the inspection, and areas that have been stabilized (temporary and/or final) since the last inspection;



(Part IV.C.4.i)

- i. Current phase of construction of all post-construction stormwater management practices and identification of all construction that is not in conformance with the SWPPP and technical standards;
  - j. Corrective action(s) that must be taken to install, repair, replace or maintain erosion and sediment control practices and pollution prevention measures; and to correct deficiencies identified with the construction of the post-construction stormwater management practice(s);
  - k. Identification and status of all corrective actions that were required by previous inspection; and
  - l. Digital photographs, with date stamp, that clearly show the condition of all practices that have been identified as needing corrective actions. The *qualified inspector* shall attach paper color copies of the digital photographs to the inspection report being maintained onsite within seven (7) calendar days of the date of the inspection. The *qualified inspector* shall also take digital photographs, with date stamp, that clearly show the condition of the practice(s) after the corrective action has been completed. The *qualified inspector* shall attach paper color copies of the digital photographs to the inspection report that documents the completion of the corrective action work within seven (7) calendar days of that inspection.
5. Within one business day of the completion of an inspection, the *qualified inspector* shall notify the *owner or operator* and appropriate contractor or subcontractor identified in Part III.A.6. of this permit of any corrective actions that need to be taken. The contractor or subcontractor shall begin implementing the corrective actions within one business day of this notification and shall complete the corrective actions in a reasonable time frame.
  6. All inspection reports shall be signed by the *qualified inspector*. Pursuant to Part II.C.2. of this permit, the inspection reports shall be maintained on site with the SWPPP.

## **Part V. TERMINATION OF PERMIT COVERAGE**

### **A. Termination of Permit Coverage**

1. An *owner or operator* that is eligible to terminate coverage under this permit must submit a completed NOT form to the address in Part II.A.1 of this permit. The NOT form shall be one which is associated with this permit, signed in accordance with Part VII.H of this permit.

(Part V.A.2)

2. An *owner or operator* may terminate coverage when one or more the following conditions have been met:
  - a. Total project completion - All *construction activity* identified in the SWPPP has been completed; and all areas of disturbance have achieved *final stabilization*; and all temporary, structural erosion and sediment control measures have been removed; and all post-construction stormwater management practices have been constructed in conformance with the SWPPP and are operational;
  - b. Planned shutdown with partial project completion - All soil disturbance activities have ceased; and all areas disturbed as of the project shutdown date have achieved *final stabilization*; and all temporary, structural erosion and sediment control measures have been removed; and all post-construction stormwater management practices required for the completed portion of the project have been constructed in conformance with the SWPPP and are operational;
  - c. A new *owner or operator* has obtained coverage under this permit in accordance with Part II.E. of this permit.
  - d. The *owner or operator* obtains coverage under an alternative SPDES general permit or an individual SPDES permit.
3. For *construction activities* meeting subdivision 2a. or 2b. of this Part, the *owner or operator* shall have the *qualified inspector* perform a final site inspection prior to submitting the NOT. The *qualified inspector* shall, by signing the “*Final Stabilization*” and “*Post-Construction Stormwater Management Practice certification statements*” on the NOT, certify that all the requirements in Part V.A.2.a. or b. of this permit have been achieved.
4. For *construction activities* that are subject to the requirements of a *regulated, traditional land use control MS4* and meet subdivision 2a. or 2b. of this Part, the *owner or operator* shall have the *regulated, traditional land use control MS4* sign the “*MS4 Acceptance*” statement on the NOT in accordance with the requirements in Part VII.H. of this permit. The *regulated, traditional land use control MS4* official, by signing this statement, has determined that it is acceptable for the *owner or operator* to submit the NOT in accordance with the requirements of this Part. The *regulated, traditional land use control MS4* can make this determination by performing a final site inspection themselves or by accepting the *qualified inspector’s* final site inspection certification(s) required in Part V.A.3. of this permit.

(Part V.A.5)

5. For *construction activities* that require post-construction stormwater management practices and meet subdivision 2a. of this Part, the *owner or operator* must, prior to submitting the NOT, ensure one of the following:
  - a. the post-construction stormwater management practice(s) and any right-of-way(s) needed to maintain such practice(s) have been deeded to the municipality in which the practice(s) is located,
  - b. an executed maintenance agreement is in place with the municipality that will maintain the post-construction stormwater management practice(s),
  - c. for post-construction stormwater management practices that are privately owned, the *owner or operator* has a mechanism in place that requires operation and maintenance of the practice(s) in accordance with the operation and maintenance plan, such as a deed covenant in the *owner or operator's* deed of record,
  - d. for post-construction stormwater management practices that are owned by a public or private institution (e.g. school, university, hospital), government agency or authority, or public utility; the *owner or operator* has policy and procedures in place that ensures operation and maintenance of the practices in accordance with the operation and maintenance plan.

## **Part VI. REPORTING AND RETENTION OF RECORDS**

### **A. Record Retention**

The *owner or operator* shall retain a copy of the NOI, NOI Acknowledgment Letter, SWPPP, MS4 SWPPP Acceptance form and any inspection reports that were prepared in conjunction with this permit for a period of at least five (5) years from the date that the Department receives a complete NOT submitted in accordance with Part V. of this general permit.

### **B. Addresses**

With the exception of the NOI, NOT, and MS4 SWPPP Acceptance form (which must be submitted to the address referenced in Part II.A.1 of this permit), all written correspondence requested by the Department, including individual permit applications, shall be sent to the address of the appropriate DOW Water (SPDES) Program contact at the Regional Office listed in Appendix F.

(Part VII)

## **Part VII. STANDARD PERMIT CONDITIONS**

### **A. Duty to Comply**

The *owner or operator* must comply with all conditions of this permit. All contractors and subcontractors associated with the project must comply with the terms of the SWPPP. Any non-compliance with this permit constitutes a violation of the Clean Water Act (CWA) and the ECL and is grounds for an enforcement action against the *owner or operator* and/or the contractor/subcontractor; permit revocation, suspension or modification; or denial of a permit renewal application. Upon a finding of significant non-compliance with this permit or the applicable SWPPP, the Department may order an immediate stop to all *construction activity* at the site until the non-compliance is remedied. The stop work order shall be in writing, shall describe the non-compliance in detail, and shall be sent to the *owner or operator*.

If any human remains or archaeological remains are encountered during excavation, the *owner or operator* must immediately cease, or cause to cease, all *construction activity* in the area of the remains and notify the appropriate Regional Water Engineer (RWE). *Construction activity* shall not resume until written permission to do so has been received from the RWE.

### **B. Continuation of the Expired General Permit**

This permit expires five (5) years from the effective date. If a new general permit is not issued prior to the expiration of this general permit, an *owner or operator* with coverage under this permit may continue to operate and *discharge* in accordance with the terms and conditions of this general permit, if it is extended pursuant to the State Administrative Procedure Act and 6 NYCRR Part 621, until a new general permit is issued.

### **C. Enforcement**

Failure of the *owner or operator*, its contractors, subcontractors, agents and/or assigns to strictly adhere to any of the permit requirements contained herein shall constitute a violation of this permit. There are substantial criminal, civil, and administrative penalties associated with violating the provisions of this permit. Fines of up to \$37,500 per day for each violation and imprisonment for up to fifteen (15) years may be assessed depending upon the nature and degree of the offense.

### **D. Need to Halt or Reduce Activity Not a Defense**

It shall not be a defense for an *owner or operator* in an enforcement action that it would have been necessary to halt or reduce the *construction activity* in order to maintain compliance with the conditions of this permit.

(Part VII.E)

### **E. Duty to Mitigate**

The *owner or operator* and its contractors and subcontractors shall take all reasonable steps to *minimize* or prevent any *discharge* in violation of this permit which has a reasonable likelihood of adversely affecting human health or the environment.

### **F. Duty to Provide Information**

The *owner or operator* shall furnish to the Department, within a reasonable specified time period of a written request, all documentation necessary to demonstrate eligibility and any information to determine compliance with this permit or to determine whether cause exists for modifying or revoking this permit, or suspending or denying coverage under this permit, in accordance with the terms and conditions of this permit. The NOI, SWPPP and inspection reports required by this permit are public documents that the *owner or operator* must make available for review and copying by any person within five (5) business days of the *owner or operator* receiving a written request by any such person to review these documents. Copying of documents will be done at the requester's expense.

### **G. Other Information**

When the *owner or operator* becomes aware that they failed to submit any relevant facts, or submitted incorrect information in the NOI or in any of the documents required by this permit, or have made substantive revisions to the SWPPP (e.g. the scope of the project changes significantly, the type of post-construction stormwater management practice(s) changes, there is a reduction in the sizing of the post-construction stormwater management practice, or there is an increase in the disturbance area or *impervious area*), which were not reflected in the original NOI submitted to the Department, they shall promptly submit such facts or information to the Department using the contact information in Part II.A. of this permit. Failure of the *owner or operator* to correct or supplement any relevant facts within five (5) business days of becoming aware of the deficiency shall constitute a violation of this permit.

### **H. Signatory Requirements**

1. All NOIs and NOTs shall be signed as follows:
  - a. For a corporation these forms shall be signed by a responsible corporate officer. For the purpose of this section, a responsible corporate officer means:
    - (i) a president, secretary, treasurer, or vice-president of the

(Part VII.H.1.a.i)

corporation in charge of a principal business function, or any other person who performs similar policy or decision-making functions for the corporation; or

- (ii) the manager of one or more manufacturing, production or operating facilities, provided the manager is authorized to make management decisions which govern the operation of the regulated facility including having the explicit or implicit duty of making major capital investment recommendations, and initiating and directing other comprehensive measures to assure long term environmental compliance with environmental laws and regulations; the manager can ensure that the necessary systems are established or actions taken to gather complete and accurate information for permit application requirements; and where authority to sign documents has been assigned or delegated to the manager in accordance with corporate procedures;

b. For a partnership or sole proprietorship these forms shall be signed by a general partner or the proprietor, respectively; or

c. For a municipality, State, Federal, or other public agency these forms shall be signed by either a principal executive officer or ranking elected official. For purposes of this section, a principal executive officer of a Federal agency includes:

- (i) the chief executive officer of the agency, or

- (ii) a senior executive officer having responsibility for the overall operations of a principal geographic unit of the agency (e.g., Regional Administrators of EPA).

2. The SWPPP and other information requested by the Department shall be signed by a person described in Part VII.H.1. of this permit or by a duly authorized representative of that person. A person is a duly authorized representative only if:

a. The authorization is made in writing by a person described in Part VII.H.1. of this permit;

b. The authorization specifies either an individual or a position having responsibility for the overall operation of the regulated facility or activity, such as the position of plant manager, operator of a well or a well field, superintendent, position of *equivalent* responsibility, or an individual or position having overall responsibility for environmental matters for the company. (A duly authorized representative may thus be either a named

(Part VII.H.2.b)

individual or any individual occupying a named position) and,

- c. The written authorization shall include the name, title and signature of the authorized representative and be attached to the SWPPP.
3. All inspection reports shall be signed by the *qualified inspector* that performs the inspection.
4. The MS4 SWPPP Acceptance form shall be signed by the principal executive officer or ranking elected official from the *regulated, traditional land use control MS4*, or by a duly authorized representative of that person.

It shall constitute a permit violation if an incorrect and/or improper signatory authorizes any required forms, SWPPP and/or inspection reports.

#### **I. Property Rights**

The issuance of this permit does not convey any property rights of any sort, nor any exclusive privileges, nor does it authorize any injury to private property nor any invasion of personal rights, nor any infringement of Federal, State or local laws or regulations. *Owners or operators* must obtain any applicable conveyances, easements, licenses and/or access to real property prior to *commencing construction activity*.

#### **J. Severability**

The provisions of this permit are severable, and if any provision of this permit, or the application of any provision of this permit to any circumstance, is held invalid, the application of such provision to other circumstances, and the remainder of this permit shall not be affected thereby.

#### **K. Requirement to Obtain Coverage Under an Alternative Permit**

1. The Department may require any *owner or operator* authorized by this permit to apply for and/or obtain either an individual SPDES permit or another SPDES general permit. When the Department requires any *discharger* authorized by a general permit to apply for an individual SPDES permit, it shall notify the *discharger* in writing that a permit application is required. This notice shall include a brief statement of the reasons for this decision, an application form, a statement setting a time frame for the *owner or operator* to file the application for an individual SPDES permit, and a deadline, not sooner than 180 days from *owner or operator* receipt of the notification letter, whereby the authorization to

(Part VII.K.1)

*discharge* under this general permit shall be terminated. Applications must be submitted to the appropriate Permit Administrator at the Regional Office. The Department may grant additional time upon demonstration, to the satisfaction of the Department, that additional time to apply for an alternative authorization is necessary or where the Department has not provided a permit determination in accordance with Part 621 of this Title.

2. When an individual SPDES permit is issued to a discharger authorized to *discharge* under a general SPDES permit for the same *discharge(s)*, the general permit authorization for outfalls authorized under the individual SPDES permit is automatically terminated on the effective date of the individual permit unless termination is earlier in accordance with 6 NYCRR Part 750.

#### **L. Proper Operation and Maintenance**

The *owner or operator* shall at all times properly operate and maintain all facilities and systems of treatment and control (and related appurtenances) which are installed or used by the *owner or operator* to achieve compliance with the conditions of this permit and with the requirements of the SWPPP.

#### **M. Inspection and Entry**

The *owner or operator* shall allow an authorized representative of the Department, EPA, applicable county health department, or, in the case of a construction site which *discharges* through an *MS4*, an authorized representative of the *MS4* receiving the discharge, upon the presentation of credentials and other documents as may be required by law, to:

1. Enter upon the *owner's or operator's* premises where a regulated facility or activity is located or conducted or where records must be kept under the conditions of this permit;
2. Have access to and copy at reasonable times, any records that must be kept under the conditions of this permit; and
3. Inspect at reasonable times any facilities or equipment (including monitoring and control equipment), practices or operations regulated or required by this permit.
4. Sample or monitor at reasonable times, for purposes of assuring permit compliance or as otherwise authorized by the Act or ECL, any substances or parameters at any location.



(Part VII.N)

**N. Permit Actions**

This permit may, at any time, be modified, suspended, revoked, or renewed by the Department in accordance with 6 NYCRR Part 621. The filing of a request by the *owner or operator* for a permit modification, revocation and reissuance, termination, a notification of planned changes or anticipated noncompliance does not limit, diminish and/or stay compliance with any terms of this permit.

**O. Definitions**

Definitions of key terms are included in Appendix A of this permit.

**P. Re-Opener Clause**

1. If there is evidence indicating potential or realized impacts on water quality due to any stormwater discharge associated with *construction activity* covered by this permit, the *owner or operator* of such discharge may be required to obtain an individual permit or alternative general permit in accordance with Part VII.K. of this permit or the permit may be modified to include different limitations and/or requirements.
2. Any Department initiated permit modification, suspension or revocation will be conducted in accordance with 6 NYCRR Part 621, 6 NYCRR 750-1.18, and 6 NYCRR 750-1.20.

**Q. Penalties for Falsification of Forms and Reports**

In accordance with 6NYCRR Part 750-2.4 and 750-2.5, any person who knowingly makes any false material statement, representation, or certification in any application, record, report or other document filed or required to be maintained under this permit, including reports of compliance or noncompliance shall, upon conviction, be punished in accordance with ECL §71-1933 and or Articles 175 and 210 of the New York State Penal Law.

**R. Other Permits**

Nothing in this permit relieves the *owner or operator* from a requirement to obtain any other permits required by law.

## APPENDIX A

### Definitions

**Alter Hydrology from Pre to Post-Development Conditions** - means the post-development peak flow rate(s) has increased by more than 5% of the pre-developed condition for the design storm of interest (e.g. 10 yr and 100 yr).

**Combined Sewer** - means a sewer that is designed to collect and convey both “sewage” and “stormwater”.

**Commence (Commencement of) Construction Activities** - means the initial disturbance of soils associated with clearing, grading or excavation activities; or other construction related activities that disturb or expose soils such as demolition, stockpiling of fill material, and the initial installation of erosion and sediment control practices required in the SWPPP. See definition for “*Construction Activity(ies)*” also.

**Construction Activity(ies)** - means any clearing, grading, excavation, filling, demolition or stockpiling activities that result in soil disturbance. Clearing activities can include, but are not limited to, logging equipment operation, the cutting and skidding of trees, stump removal and/or brush root removal. Construction activity does not include routine maintenance that is performed to maintain the original line and grade, hydraulic capacity, or original purpose of a facility.

**Direct Discharge (to a specific surface waterbody)** - means that runoff flows from a construction site by overland flow and the first point of discharge is the specific surface waterbody, or runoff flows from a construction site to a separate storm sewer system and the first point of discharge from the separate storm sewer system is the specific surface waterbody.

**Discharge(s)** - means any addition of any pollutant to waters of the State through an outlet or point source.

**Environmental Conservation Law (ECL)** - means chapter 43-B of the Consolidated Laws of the State of New York, entitled the Environmental Conservation Law.

**Equivalent (Equivalence)** – means that the practice or measure meets all the performance, longevity, maintenance, and safety objectives of the technical standard and will provide an equal or greater degree of water quality protection.

**Final Stabilization** - means that all soil disturbance activities have ceased and a uniform, perennial vegetative cover with a density of eighty (80) percent over the entire pervious surface has been established; or other equivalent stabilization measures, such as permanent landscape mulches, rock rip-rap or washed/crushed stone have been applied

on all disturbed areas that are not covered by permanent structures, concrete or pavement.

**General SPDES permit** - means a SPDES permit issued pursuant to 6 NYCRR Part 750-1.21 and Section 70-0117 of the ECL authorizing a category of discharges.

**Groundwater(s)** - means waters in the saturated zone. The saturated zone is a subsurface zone in which all the interstices are filled with water under pressure greater than that of the atmosphere. Although the zone may contain gas-filled interstices or interstices filled with fluids other than water, it is still considered saturated.

**Historic Property** – means any building, structure, site, object or district that is listed on the State or National Registers of Historic Places or is determined to be eligible for listing on the State or National Registers of Historic Places.

**Impervious Area (Cover)** - means all impermeable surfaces that cannot effectively infiltrate rainfall. This includes paved, concrete and gravel surfaces (i.e. parking lots, driveways, roads, runways and sidewalks); building rooftops and miscellaneous impermeable structures such as patios, pools, and sheds.

**Infeasible** – means not technologically possible, or not economically practicable and achievable in light of best industry practices.

**Larger Common Plan of Development or Sale** - means a contiguous area where multiple separate and distinct *construction activities* are occurring, or will occur, under one plan. The term “plan” in “larger common plan of development or sale” is broadly defined as any announcement or piece of documentation (including a sign, public notice or hearing, marketing plan, advertisement, drawing, permit application, State Environmental Quality Review Act (SEQRA) environmental assessment form or other documents, zoning request, computer design, etc.) or physical demarcation (including boundary signs, lot stakes, surveyor markings, etc.) indicating that *construction activities* may occur on a specific plot.

For discrete construction projects that are located within a larger common plan of development or sale that are at least 1/4 mile apart, each project can be treated as a separate plan of development or sale provided any interconnecting road, pipeline or utility project that is part of the same “common plan” is not concurrently being disturbed.

**Minimize** – means reduce and/or eliminate to the extent achievable using control measures (including best management practices) that are technologically available and economically practicable and achievable in light of best industry practices.

**Municipal Separate Storm Sewer (MS4)** - a conveyance or system of conveyances (including roads with drainage systems, municipal streets, catch basins, curbs, gutters,

ditches, man-made channels, or storm drains):

- (i) Owned or operated by a State, city, town, borough, county, parish, district, association, or other public body (created by or pursuant to State law) having jurisdiction over disposal of sewage, industrial wastes, stormwater, or other wastes, including special districts under State law such as a sewer district, flood control district or drainage district, or similar entity, or an Indian tribe or an authorized Indian tribal organization, or a designated and approved management agency under section 208 of the CWA that discharges to surface waters of the State;
- (ii) Designed or used for collecting or conveying stormwater;
- (iii) Which is not a *combined sewer*; and
- (iv) Which is not part of a Publicly Owned Treatment Works (POTW) as defined at 40 CFR 122.2.

**National Pollutant Discharge Elimination System (NPDES)** - means the national system for the issuance of wastewater and stormwater permits under the Federal Water Pollution Control Act (Clean Water Act).

**New Development** – means any land disturbance that does not meet the definition of Redevelopment Activity included in this appendix.

**NOI Acknowledgment Letter** - means the letter that the Department sends to an owner or operator to acknowledge the Department's receipt and acceptance of a complete Notice of Intent. This letter documents the owner's or operator's authorization to discharge in accordance with the general permit for stormwater discharges from *construction activity*.

**Owner or Operator** - means the person, persons or legal entity which owns or leases the property on which the *construction activity* is occurring; and/or an entity that has operational control over the construction plans and specifications, including the ability to make modifications to the plans and specifications.

**Performance Criteria** – means the design criteria listed under the “Required Elements” sections in Chapters 5, 6 and 10 of the technical standard, New York State Stormwater Management Design Manual, dated January 2015. It does not include the Sizing Criteria (i.e. WQv, RRv, Cpv, Qp and Qf ) in Part I.C.2. of the permit.

**Pollutant** - means dredged spoil, filter backwash, solid waste, incinerator residue, sewage, garbage, sewage sludge, munitions, chemical wastes, biological materials, radioactive materials, heat, wrecked or discarded equipment, rock, sand and industrial, municipal, agricultural waste and ballast discharged into water; which may cause or might reasonably be expected to cause pollution of the waters of the state in contravention of the standards or guidance values adopted as provided in 6 NYCRR Parts 700 et seq .

**Qualified Inspector** - means a person that is knowledgeable in the principles and practices of erosion and sediment control, such as a licensed Professional Engineer, Certified Professional in Erosion and Sediment Control (CPESC), Registered Landscape Architect, or other Department endorsed individual(s).

It can also mean someone working under the direct supervision of, and at the same company as, the licensed Professional Engineer or Registered Landscape Architect, provided that person has training in the principles and practices of erosion and sediment control. Training in the principles and practices of erosion and sediment control means that the individual working under the direct supervision of the licensed Professional Engineer or Registered Landscape Architect has received four (4) hours of Department endorsed training in proper erosion and sediment control principles from a Soil and Water Conservation District, or other Department endorsed entity. After receiving the initial training, the individual working under the direct supervision of the licensed Professional Engineer or Registered Landscape Architect shall receive four (4) hours of training every three (3) years.

It can also mean a person that meets the *Qualified Professional* qualifications in addition to the *Qualified Inspector* qualifications.

Note: Inspections of any post-construction stormwater management practices that include structural components, such as a dam for an impoundment, shall be performed by a licensed Professional Engineer.

**Qualified Professional** - means a person that is knowledgeable in the principles and practices of stormwater management and treatment, such as a licensed Professional Engineer, Registered Landscape Architect or other Department endorsed individual(s). Individuals preparing SWPPPs that require the post-construction stormwater management practice component must have an understanding of the principles of hydrology, water quality management practice design, water quantity control design, and, in many cases, the principles of hydraulics. All components of the SWPPP that involve the practice of engineering, as defined by the NYS Education Law (see Article 145), shall be prepared by, or under the direct supervision of, a professional engineer licensed to practice in the State of New York..

**Redevelopment Activity(ies)** – means the disturbance and reconstruction of existing impervious area, including impervious areas that were removed from a project site within five (5) years of preliminary project plan submission to the local government (i.e. site plan, subdivision, etc.).

**Regulated, Traditional Land Use Control MS4** - means a city, town or village with land use control authority that is required to gain coverage under New York State DEC's SPDES General Permit For Stormwater Discharges from Municipal Separate Stormwater Sewer Systems (MS4s).

**Routine Maintenance Activity** - means *construction activity* that is performed to maintain the original line and grade, hydraulic capacity, or original purpose of a facility, including, but not limited to:

- Re-grading of gravel roads or parking lots,
- Stream bank restoration projects (does not include the placement of spoil material),
- Cleaning and shaping of existing roadside ditches and culverts that maintains the approximate original line and grade, and hydraulic capacity of the ditch,
- Cleaning and shaping of existing roadside ditches that does not maintain the approximate original grade, hydraulic capacity and purpose of the ditch if the changes to the line and grade, hydraulic capacity or purpose of the ditch are installed to improve water quality and quantity controls (e.g. installing grass lined ditch),
- Placement of aggregate shoulder backing that makes the transition between the road shoulder and the ditch or embankment,
- Full depth milling and filling of existing asphalt pavements, replacement of concrete pavement slabs, and similar work that does not expose soil or disturb the bottom six (6) inches of subbase material,
- Long-term use of equipment storage areas at or near highway maintenance facilities,
- Removal of sediment from the edge of the highway to restore a previously existing sheet-flow drainage connection from the highway surface to the highway ditch or embankment,
- Existing use of Canal Corp owned upland disposal sites for the canal, and
- Replacement of curbs, gutters, sidewalks and guide rail posts.

**Site limitations** – means site conditions that prevent the use of an infiltration technique and or infiltration of the total WQv. Typical site limitations include: seasonal high groundwater, shallow depth to bedrock, and soils with an infiltration rate less than 0.5 inches/hour. The existence of site limitations shall be confirmed and documented using actual field testing (i.e. test pits, soil borings, and infiltration test) or using information from the most current United States Department of Agriculture (USDA) Soil Survey for the County where the project is located.

**Sizing Criteria** – means the criteria included in Part I.C.2 of the permit that are used to size post-construction stormwater management control practices. The criteria include; Water Quality Volume (WQv), Runoff Reduction Volume (RRv), Channel Protection Volume (Cpv), Overbank Flood (Qp), and Extreme Flood (Qf).

**State Pollutant Discharge Elimination System (SPDES)** - means the system established pursuant to Article 17 of the ECL and 6 NYCRR Part 750 for issuance of permits authorizing discharges to the waters of the state.

**Steep Slope** – means land area with a Soil Slope Phase that is identified as an E or F, or

the map unit name is inclusive of 25% or greater slope, on the United States Department of Agriculture (“USDA”) Soil Survey for the County where the disturbance will occur.

**Surface Waters of the State** - shall be construed to include lakes, bays, sounds, ponds, impounding reservoirs, springs, rivers, streams, creeks, estuaries, marshes, inlets, canals, the Atlantic ocean within the territorial seas of the state of New York and all other bodies of surface water, natural or artificial, inland or coastal, fresh or salt, public or private (except those private waters that do not combine or effect a junction with natural surface waters), which are wholly or partially within or bordering the state or within its jurisdiction. Waters of the state are further defined in 6 NYCRR Parts 800 to 941.

**Temporarily Ceased** – means that an existing disturbed area will not be disturbed again within 14 calendar days of the previous soil disturbance.

**Temporary Stabilization** - means that exposed soil has been covered with material(s) as set forth in the technical standard, New York Standards and Specifications for Erosion and Sediment Control, to prevent the exposed soil from eroding. The materials can include, but are not limited to, mulch, seed and mulch, and erosion control mats (e.g. jute twisted yarn, excelsior wood fiber mats).

**Total Maximum Daily Loads (TMDLs)** - A TMDL is the sum of the allowable loads of a single pollutant from all contributing point and nonpoint sources. It is a calculation of the maximum amount of a pollutant that a waterbody can receive on a daily basis and still meet *water quality standards*, and an allocation of that amount to the pollutant's sources. A TMDL stipulates wasteload allocations (WLAs) for point source discharges, load allocations (LAs) for nonpoint sources, and a margin of safety (MOS).

**Trained Contractor** - means an employee from the contracting (construction) company, identified in Part III.A.6., that has received four (4) hours of Department endorsed training in proper erosion and sediment control principles from a Soil and Water Conservation District, or other Department endorsed entity. After receiving the initial training, the *trained contractor* shall receive four (4) hours of training every three (3) years.

It can also mean an employee from the contracting (construction) company, identified in Part III.A.6., that meets the *qualified inspector* qualifications (e.g. licensed Professional Engineer, Certified Professional in Erosion and Sediment Control (CPESC), Registered Landscape Architect, or someone working under the direct supervision of, and at the same company as, the licensed Professional Engineer or Registered Landscape Architect, provided they have received four (4) hours of Department endorsed training in proper erosion and sediment control principles from a Soil and Water Conservation District, or other Department endorsed entity).

The *trained contractor* is responsible for the day to day implementation of the SWPPP.

**Uniform Procedures Act (UPA) Permit** - means a permit required under 6 NYCRR Part

621 of the Environmental Conservation Law (ECL), Article 70.

**Water Quality Standard** - means such measures of purity or quality for any waters in relation to their reasonable and necessary use as promulgated in 6 NYCRR Part 700 et seq.



## APPENDIX B

### Required SWPPP Components by Project Type

**Table 1**  
**CONSTRUCTION ACTIVITIES THAT REQUIRE THE PREPARATION OF A SWPPP**  
**THAT ONLY INCLUDES EROSION AND SEDIMENT CONTROLS**

**The following construction activities that involve soil disturbances of one (1) or more acres of land, but less than five (5) acres:**

- Single family home not located in one of the watersheds listed in Appendix C or not directly discharging to one of the 303(d) segments listed in Appendix E
- Single family residential subdivisions with 25% or less impervious cover at total site build-out and not located in one of the watersheds listed in Appendix C and not directly discharging to one of the 303(d) segments listed in Appendix E
- Construction of a barn or other agricultural building, silo, stock yard or pen.

**The following construction activities that involve soil disturbances of one (1) or more acres of land:**

- Installation of underground, linear utilities; such as gas lines, fiber-optic cable, cable TV, electric, telephone, sewer mains, and water mains
- Environmental enhancement projects, such as wetland mitigation projects, stormwater retrofits and stream restoration projects
- Bike paths and trails
- Sidewalk construction projects that are not part of a road/ highway construction or reconstruction project
- Slope stabilization projects
- Slope flattening that changes the grade of the site, but does not significantly change the runoff characteristics
- Spoil areas that will be covered with vegetation
- Land clearing and grading for the purposes of creating vegetated open space (i.e. recreational parks, lawns, meadows, fields), excluding projects that *alter hydrology from pre to post development* conditions
- Athletic fields (natural grass) that do not include the construction or reconstruction of *impervious area* and do not *alter hydrology from pre to post development* conditions
- Demolition project where vegetation will be established and no redevelopment is planned
- Overhead electric transmission line project that does not include the construction of permanent access roads or parking areas surfaced with *impervious cover*
- Structural practices as identified in Table II in the "Agricultural Management Practices Catalog for Nonpoint Source Pollution in New York State", excluding projects that involve soil disturbances of less than five acres and construction activities that include the construction or reconstruction of impervious area

**The following construction activities that involve soil disturbances between five thousand (5000) square feet and one (1) acre of land:**

- All construction activities located in the watersheds identified in Appendix D that involve soil disturbances between five thousand (5,000) square feet and one (1) acre of land.

**Table 2**  
**CONSTRUCTION ACTIVITIES THAT REQUIRE THE PREPARATION OF A SWPPP THAT INCLUDES**  
**POST-CONSTRUCTION STORMWATER MANAGEMENT PRACTICES**

**The following construction activities that involve soil disturbances of one (1) or more acres of land:**

- Single family home located in one of the watersheds listed in Appendix C or *directly discharging* to one of the 303(d) segments listed in Appendix E
- Single family residential subdivisions located in one of the watersheds listed in Appendix C or *directly discharging* to one of the 303(d) segments listed in Appendix E
- Single family residential subdivisions that involve soil disturbances of between one (1) and five (5) acres of land with greater than 25% impervious cover at total site build-out
- Single family residential subdivisions that involve soil disturbances of five (5) or more acres of land, and single family residential subdivisions that involve soil disturbances of less than five (5) acres that are part of a larger common plan of development or sale that will ultimately disturb five or more acres of land
- Multi-family residential developments; includes townhomes, condominiums, senior housing complexes, apartment complexes, and mobile home parks
- Airports
- Amusement parks
- Campgrounds
- Cemeteries that include the construction or reconstruction of impervious area (>5% of disturbed area) or *alter the hydrology from pre to post development* conditions
- Commercial developments
- Churches and other places of worship
- Construction of a barn or other agricultural building(e.g. silo) and structural practices as identified in Table II in the "Agricultural Management Practices Catalog for Nonpoint Source Pollution in New York State" that include the construction or reconstruction of *impervious area*, excluding projects that involve soil disturbances of less than five acres.
- Golf courses
- Institutional, includes hospitals, prisons, schools and colleges
- Industrial facilities, includes industrial parks
- Landfills
- Municipal facilities; includes highway garages, transfer stations, office buildings, POTW's and water treatment plants
- Office complexes
- Sports complexes
- Racetracks, includes racetracks with earthen (dirt) surface
- Road construction or reconstruction
- Parking lot construction or reconstruction
- Athletic fields (natural grass) that include the construction or reconstruction of impervious area (>5% of disturbed area) or *alter the hydrology from pre to post development* conditions
- Athletic fields with artificial turf
- Permanent access roads, parking areas, substations, compressor stations and well drilling pads, surfaced with *impervious cover*, and constructed as part of an over-head electric transmission line project, wind-power project, cell tower project, oil or gas well drilling project, sewer or water main project or other linear utility project
- All other construction activities that include the construction or reconstruction of *impervious area* or *alter the hydrology from pre to post development* conditions, and are not listed in Table 1

## APPENDIX C

### Watersheds Where Enhanced Phosphorus Removal Standards Are Required

Watersheds where *owners or operators* of construction activities identified in Table 2 of Appendix B must prepare a SWPPP that includes post-construction stormwater management practices designed in conformance with the Enhanced Phosphorus Removal Standards included in the technical standard, New York State Stormwater Management Design Manual (“Design Manual”).

- Entire New York City Watershed located east of the Hudson River - Figure 1
- Onondaga Lake Watershed - Figure 2
- Greenwood Lake Watershed -Figure 3
- Oscawana Lake Watershed – Figure 4
- Kinderhook Lake Watershed – Figure 5

**Figure 1 - New York City Watershed East of the Hudson**

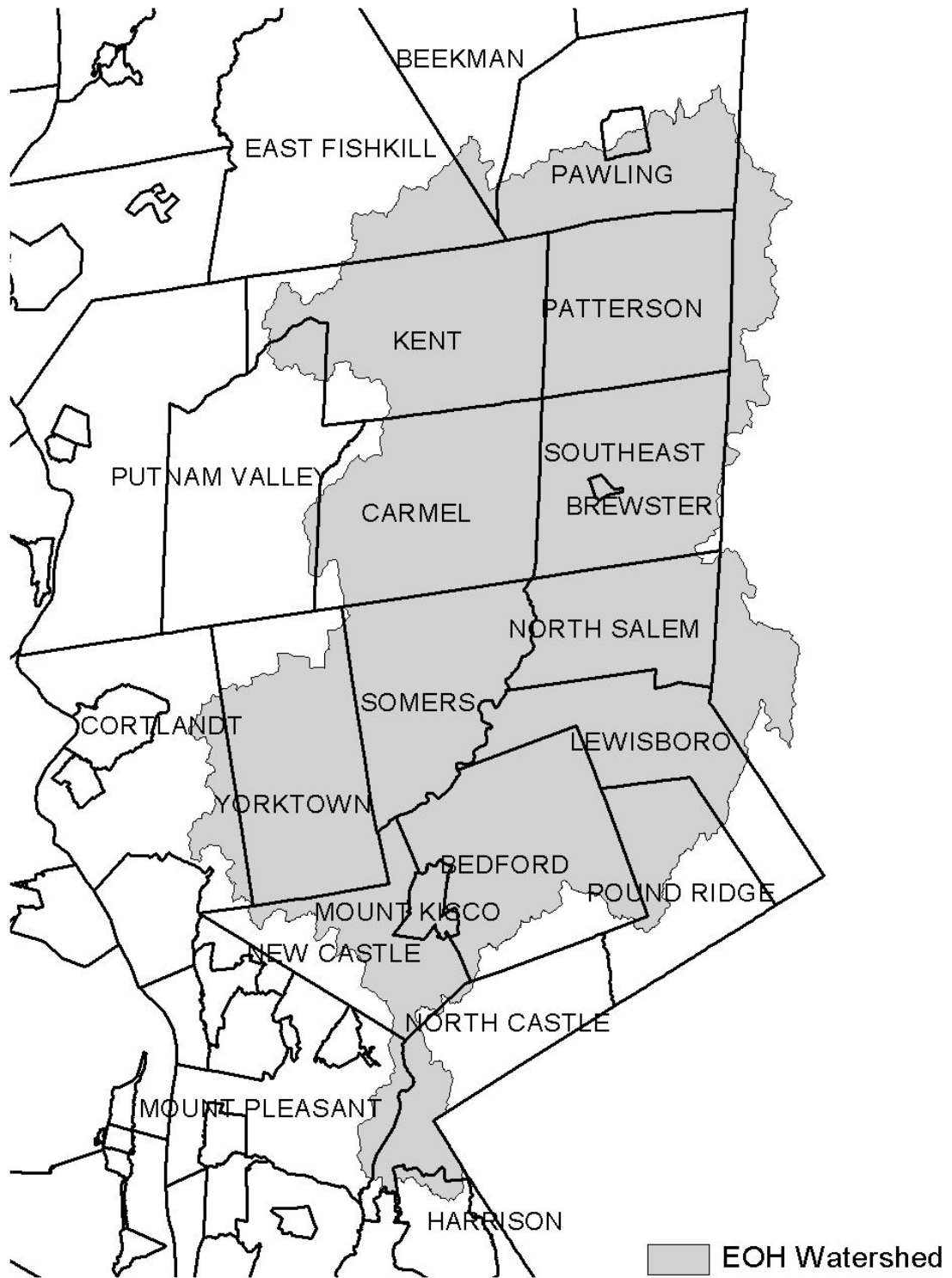

**Figure 2 - Onondaga Lake Watershed**



**Figure 3 - Greenwood Lake Watershed**

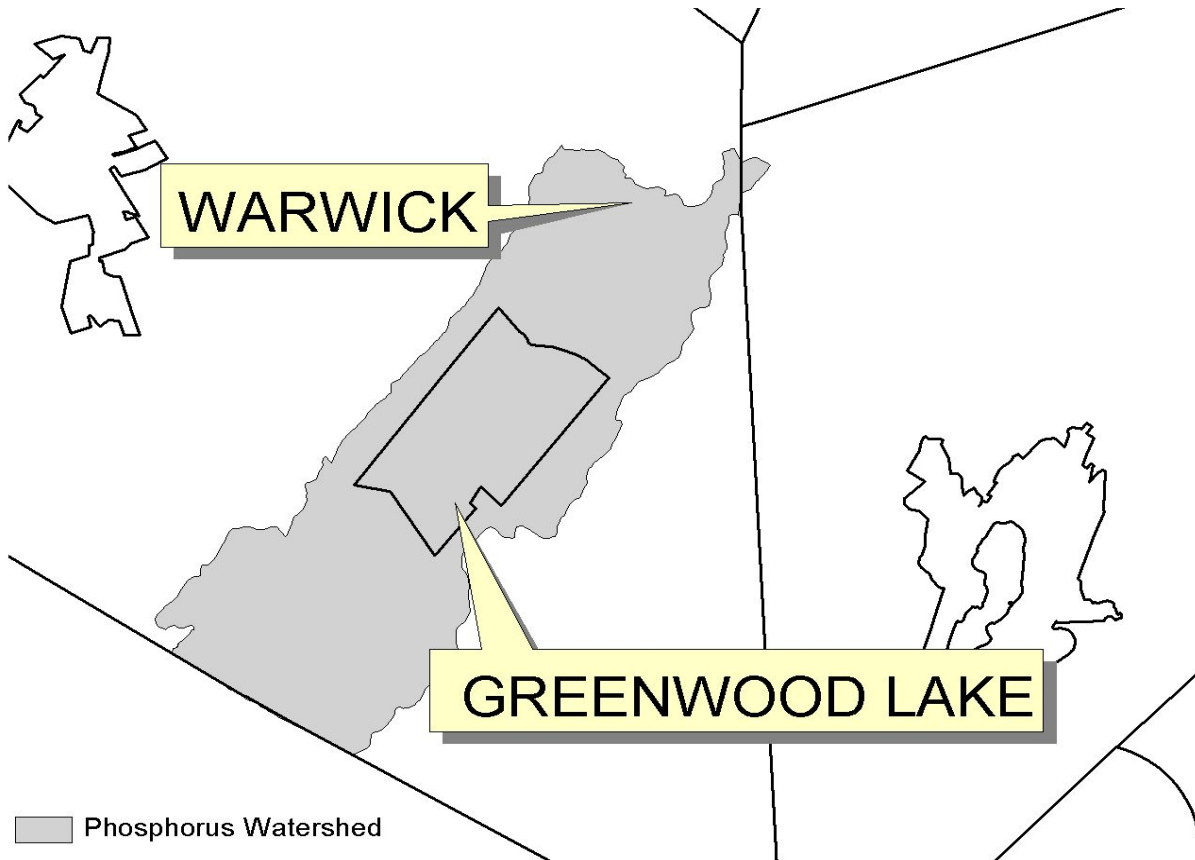

**Figure 4 - Oscawana Lake Watershed**

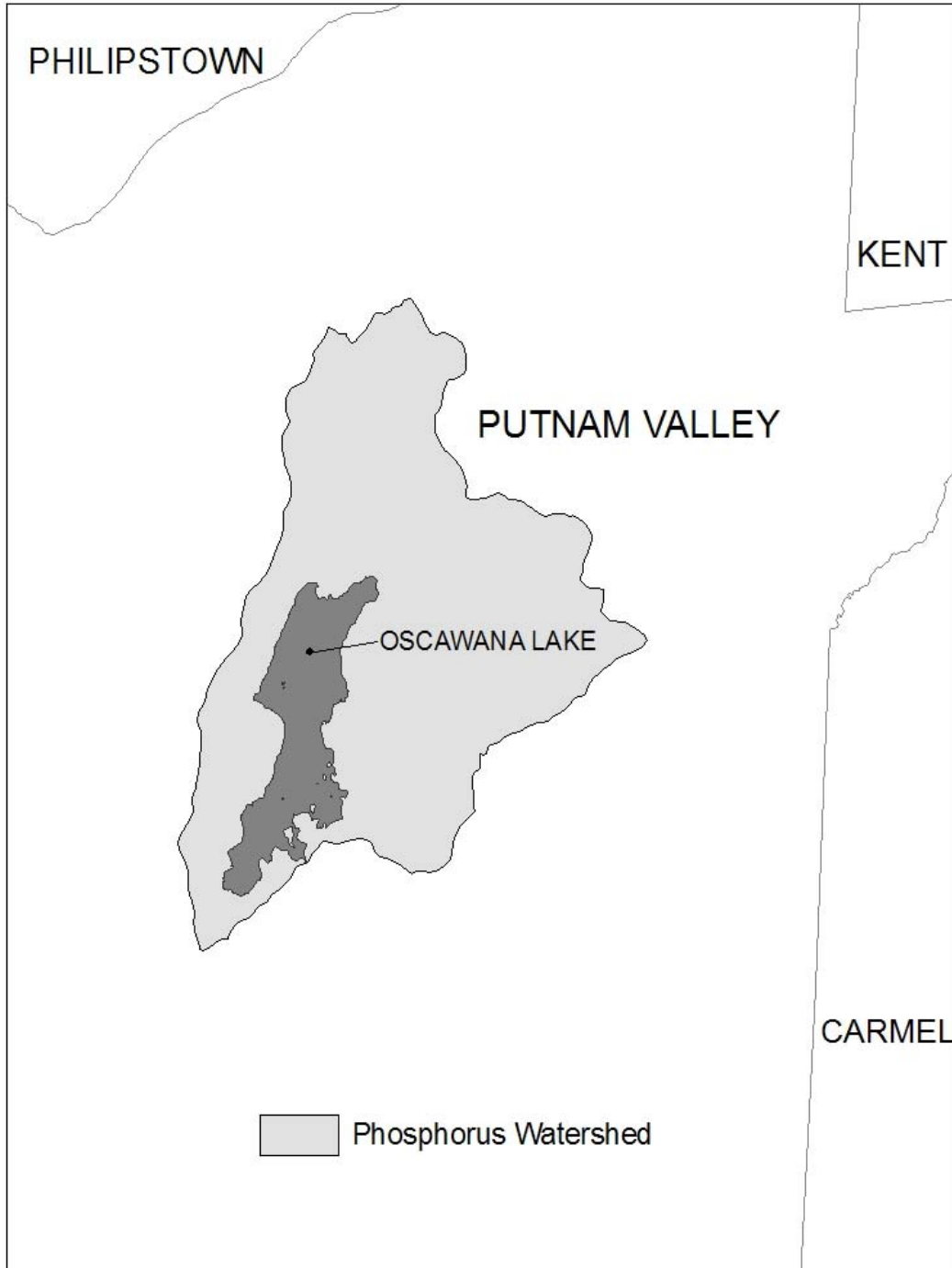
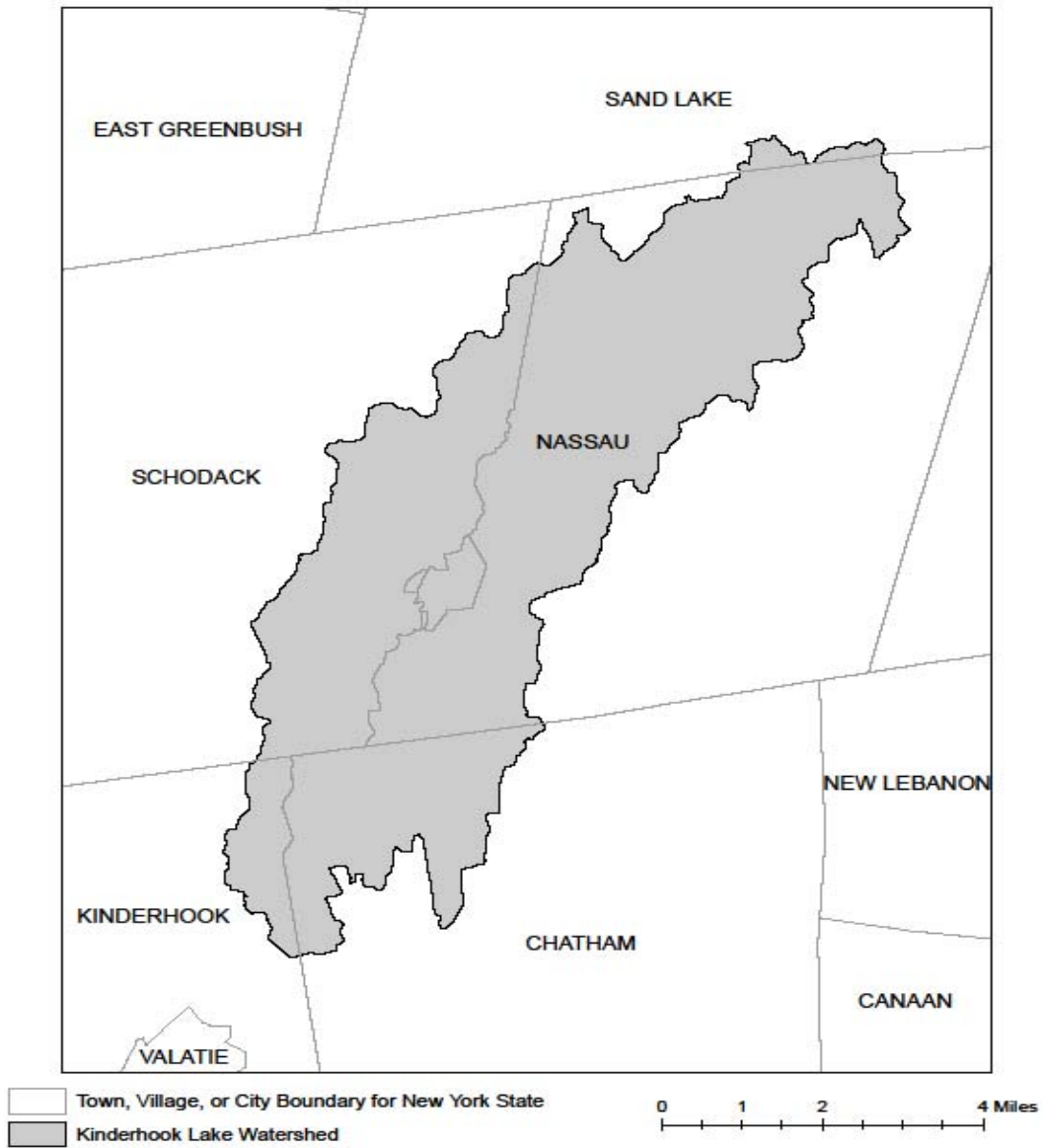

Figure 5: Kinderhook Lake Watershed





## APPENDIX D

**Watersheds where *owners or operators* of construction activities that involve soil disturbances between five thousand (5000) square feet and one (1) acre of land must obtain coverage under this permit.**

Entire New York City Watershed that is located east of the Hudson River - See Figure 1 in Appendix C

## APPENDIX E

List of 303(d) segments impaired by pollutants related to *construction activity* (e.g. silt, sediment or nutrients). *Owners or operators* of single family home and single family residential subdivisions with 25% or less total impervious cover at total site build-out that involve soil disturbances of one or more acres of land, but less than 5 acres, and *directly discharge* to one of the listed segments below shall prepare a SWPPP that includes post-construction stormwater management practices designed in conformance with the New York State Stormwater Management Design Manual (“Design Manual”), dated January 2015.

COUNTY	WATERBODY	COUNTY	WATERBODY
Albany	Ann Lee (Shakers) Pond, Stump Pond	Greene	Sleepy Hollow Lake
Albany	Basic Creek Reservoir	Herkimer	Steele Creek tribs
Allegheny	Amity Lake, Saunders Pond	Kings	Hendrix Creek
Bronx	Van Cortlandt Lake	Lewis	Mill Creek/South Branch and tribs
Broome	Whitney Point Lake/Reservoir	Livingston	Conesus Lake
Broome	Fly Pond, Deer Lake	Livingston	Jaycox Creek and tribs
Broome	Minor Tribs to Lower Susquehanna (north)	Livingston	Mill Creek and minor tribs
Cattaraugus	Allegheny River/Reservoir	Livingston	Bradner Creek and tribs
Cattaraugus	Case Lake	Livingston	Christie Creek and tribs
Cattaraugus	Linlyco/Club Pond	Monroe	Lake Ontario Shoreline, Western
Cayuga	Duck Lake	Monroe	Mill Creek/Blue Pond Outlet and tribs
Chautauqua	Chautauqua Lake, North	Monroe	Rochester Embayment - East
Chautauqua	Chautauqua Lake, South	Monroe	Rochester Embayment - West
Chautauqua	Bear Lake	Monroe	Unnamed Trib to Honeoye Creek
Chautauqua	Chadakoin River and tribs	Monroe	Genesee River, Lower, Main Stem
Chautauqua	Lower Cassadaga Lake	Monroe	Genesee River, Middle, Main Stem
Chautauqua	Middle Cassadaga Lake	Monroe	Black Creek, Lower, and minor tribs
Chautauqua	Findley Lake	Monroe	Buck Pond
Clinton	Great Chazy River, Lower, Main Stem	Monroe	Long Pond
Columbia	Kinderhook Lake	Monroe	Cranberry Pond
Columbia	Robinson Pond	Monroe	Mill Creek and tribs
Dutchess	Hillside Lake	Monroe	Shipbuilders Creek and tribs
Dutchess	Wappinger Lakes	Monroe	Minor tribs to Irondequoit Bay
Dutchess	Fall Kill and tribs	Monroe	Thomas Creek/White Brook and tribs
Erie	Green Lake	Nassau	Glen Cove Creek, Lower, and tribs
Erie	Scajaquada Creek, Lower, and tribs	Nassau	LI Tribs (fresh) to East Bay
Erie	Scajaquada Creek, Middle, and tribs	Nassau	East Meadow Brook, Upper, and tribs
Erie	Scajaquada Creek, Upper, and tribs	Nassau	Hempstead Bay
Erie	Rush Creek and tribs	Nassau	Hempstead Lake
Erie	Ellicott Creek, Lower, and tribs	Nassau	Grant Park Pond
Erie	Beeman Creek and tribs	Nassau	Beaver Lake
Erie	Murder Creek, Lower, and tribs	Nassau	Camaans Pond
Erie	South Branch Smoke Cr, Lower, and tribs	Nassau	Halls Pond
Erie	Little Sister Creek, Lower, and tribs	Nassau	LI Tidal Tribs to Hempstead Bay
Essex	Lake George (primary county: Warren)	Nassau	Massapequa Creek and tribs
Genesee	Black Creek, Upper, and minor tribs	Nassau	Reynolds Channel, east
Genesee	Tonawanda Creek, Middle, Main Stem	Nassau	Reynolds Channel, west
Genesee	Oak Orchard Creek, Upper, and tribs	Nassau	Silver Lake, Lofts Pond
Genesee	Bowen Brook and tribs	Nassau	Woodmere Channel
Genesee	Bigelow Creek and tribs	Niagara	Hyde Park Lake
Genesee	Black Creek, Middle, and minor tribs	Niagara	Lake Ontario Shoreline, Western
Genesee	LeRoy Reservoir	Niagara	Bergholtz Creek and tribs
Greene	Schoharie Reservoir	Oneida	Ballou, Nail Creeks
		Onondaga	Ley Creek and tribs
		Onondaga	Onondaga Creek, Lower and tribs

## APPENDIX E

### List of 303(d) segments impaired by pollutants related to construction activity, cont'd.

COUNTY	WATERBODY	COUNTY	WATERBODY
Onondaga	Onondaga Creek, Middle and tribs	Suffolk	Great South Bay, West
Onondaga	Onondaga Creek, Upp, and minor tribs	Suffolk	Mill and Seven Ponds
Onondaga	Harbor Brook, Lower, and tribs	Suffolk	Moriches Bay, East
Onondaga	Ninemile Creek, Lower, and tribs	Suffolk	Moriches Bay, West
Onondaga	Minor tribs to Onondaga Lake	Suffolk	Quantuck Bay
Onondaga	Onondaga Creek, Lower, and tribs	Suffolk	Shinnecock Bay (and Inlet)
Ontario	Honeoye Lake	Sullivan	Bodine, Montgomery Lakes
Ontario	Hemlock Lake Outlet and minor tribs	Sullivan	Davies Lake
Ontario	Great Brook and minor tribs	Sullivan	Pleasure Lake
Orange	Monhagen Brook and tribs	Sullivan	Swan Lake
Orange	Orange Lake	Tompkins	Cayuga Lake, Southern End
Orleans	Lake Ontario Shoreline, Western	Tompkins	Owasco Inlet, Upper, and tribs
Oswego	Pleasant Lake	Ulster	Ashokan Reservoir
Oswego	Lake Neatahwanta	Ulster	Esopus Creek, Upper, and minor tribs
Putnam	Oscawana Lake	Ulster	Esopus Creek, Lower, Main Stem
Putnam	Palmer Lake	Ulster	Esopus Creek, Middle, and minor tribs
Putnam	Lake Carmel	Warren	Lake George
Queens	Jamaica Bay, Eastern, and tribs (Queens)	Warren	Tribs to L.George, Village of L George
Queens	Bergen Basin	Warren	Huddle/Finkle Brooks and tribs
Queens	Shellbank Basin	Warren	Indian Brook and tribs
Rensselaer	Nassau Lake	Warren	Hague Brook and tribs
Rensselaer	Snyders Lake	Washington	Tribs to L.George, East Shr Lk George
Richmond	Grasmere, Arbutus and Wolfes Lakes	Washington	Cossayuna Lake
Rockland	Congers Lake, Swartout Lake	Washington	Wood Cr/Champlain Canal, minor tribs
Rockland	Rockland Lake	Wayne	Port Bay
Saratoga	Ballston Lake	Wayne	Marbletown Creek and tribs
Saratoga	Round Lake	Westchester	Lake Katonah
Saratoga	Dwaas Kill and tribs	Westchester	Lake Mohegan
Saratoga	Tribs to Lake Lonely	Westchester	Lake Shenorock
Saratoga	Lake Lonely	Westchester	Reservoir No.1 (Lake Isle)
Schenectady	Collins Lake	Westchester	Saw Mill River, Middle, and tribs
Schenectady	Duane Lake	Westchester	Silver Lake
Schenectady	Mariaville Lake	Westchester	Teatown Lake
Schoharie	Engleville Pond	Westchester	Truesdale Lake
Schoharie	Summit Lake	Westchester	Wallace Pond
Schuyler	Cayuta Lake	Westchester	Peach Lake
St. Lawrence	Fish Creek and minor tribs	Westchester	Mamaroneck River, Lower
St. Lawrence	Black Lake Outlet/Black Lake	Westchester	Mamaroneck River, Upp, and tribs
Steuben	Lake Salubria	Westchester	Sheldrake River and tribs
Steuben	Smith Pond	Westchester	Blind Brook, Lower
Suffolk	Millers Pond	Westchester	Blind Brook, Upper, and tribs
Suffolk	Mattituck (Marratooka) Pond	Westchester	Lake Lincolndale
Suffolk	Tidal tribs to West Moriches Bay	Westchester	Lake Meahaugh
Suffolk	Canaan Lake	Wyoming	Java Lake
Suffolk	Lake Ronkonkoma	Wyoming	Silver Lake
Suffolk	Beaverdam Creek and tribs		
Suffolk	Big/Little Fresh Ponds		
Suffolk	Fresh Pond		
Suffolk	Great South Bay, East		
Suffolk	Great South Bay, Middle		

Note: The list above identifies those waters from the final New York State "2014 Section 303(d) List of Impaired Waters Requiring a TMDL/Other Strategy", dated January 2015, that are impaired by silt, sediment or nutrients.

**APPENDIX F**

**LIST OF NYS DEC REGIONAL OFFICES**

<b><u>Region</u></b>	<b><u>COVERING THE FOLLOWING COUNTIES:</u></b>	<b><u>DIVISION OF ENVIRONMENTAL PERMITS (DEP) PERMIT ADMINISTRATORS</u></b>	<b><u>DIVISION OF WATER (DOW) WATER (SPDES) PROGRAM</u></b>
<b>1</b>	NASSAU AND SUFFOLK	50 CIRCLE ROAD STONY BROOK, NY 11790 TEL. (631) 444-0365	50 CIRCLE ROAD STONY BROOK, NY 11790-3409 TEL. (631) 444-0405
<b>2</b>	BRONX, KINGS, NEW YORK, QUEENS AND RICHMOND	1 HUNTERS POINT PLAZA, 47-40 21ST ST. LONG ISLAND CITY, NY 11101-5407 TEL. (718) 482-4997	1 HUNTERS POINT PLAZA, 47-40 21ST ST. LONG ISLAND CITY, NY 11101-5407 TEL. (718) 482-4933
<b>3</b>	DUTCHESS, ORANGE, PUTNAM, ROCKLAND, SULLIVAN, ULSTER AND WESTCHESTER	21 SOUTH PUTT CORNERS ROAD NEW PALTZ, NY 12561-1696 TEL. (845) 256-3059	100 HILLSIDE AVENUE, SUITE 1W WHITE PLAINS, NY 10603 TEL. (914) 428 - 2505
<b>4</b>	ALBANY, COLUMBIA, DELAWARE, GREENE, MONTGOMERY, OTSEGO, RENSSELAER, SCHENECTADY AND SCHOHARIE	1150 NORTH WESTCOTT ROAD SCHENECTADY, NY 12306-2014 TEL. (518) 357-2069	1130 NORTH WESTCOTT ROAD SCHENECTADY, NY 12306-2014 TEL. (518) 357-2045
<b>5</b>	CLINTON, ESSEX, FRANKLIN, FULTON, HAMILTON, SARATOGA, WARREN AND WASHINGTON	1115 STATE ROUTE 86, Po Box 296 RAY BROOK, NY 12977-0296 TEL. (518) 897-1234	232 GOLF COURSE ROAD WARRENSBURG, NY 12885-1172 TEL. (518) 623-1200
<b>6</b>	HERKIMER, JEFFERSON, LEWIS, ONEIDA AND ST. LAWRENCE	STATE OFFICE BUILDING 317 WASHINGTON STREET WATERTOWN, NY 13601-3787 TEL. (315) 785-2245	STATE OFFICE BUILDING 207 GENESEE STREET UTICA, NY 13501-2885 TEL. (315) 793-2554
<b>7</b>	BROOME, CAYUGA, CHENANGO, CORTLAND, MADISON, ONONDAGA, OSWEGO, TIOGA AND TOMPKINS	615 ERIE BLVD. WEST SYRACUSE, NY 13204-2400 TEL. (315) 426-7438	615 ERIE BLVD. WEST SYRACUSE, NY 13204-2400 TEL. (315) 426-7500
<b>8</b>	CHEMUNG, GENESEE, LIVINGSTON, MONROE, ONTARIO, ORLEANS, SCHUYLER, SENECA, STEUBEN, WAYNE AND YATES	6274 EAST AVON-LIMA ROAD AVON, NY 14414-9519 TEL. (585) 226-2466	6274 EAST AVON-LIMA RD. AVON, NY 14414-9519 TEL. (585) 226-2466
<b>9</b>	ALLEGANY, CATTARAUGUS, CHAUTAUQUA, ERIE, NIAGARA AND WYOMING	270 MICHIGAN AVENUE BUFFALO, NY 14203-2999 TEL. (716) 851-7165	270 MICHIGAN AVE. BUFFALO, NY 14203-2999 TEL. (716) 851-7070

**APPENDIX O**  
**Drainage Area Maps**



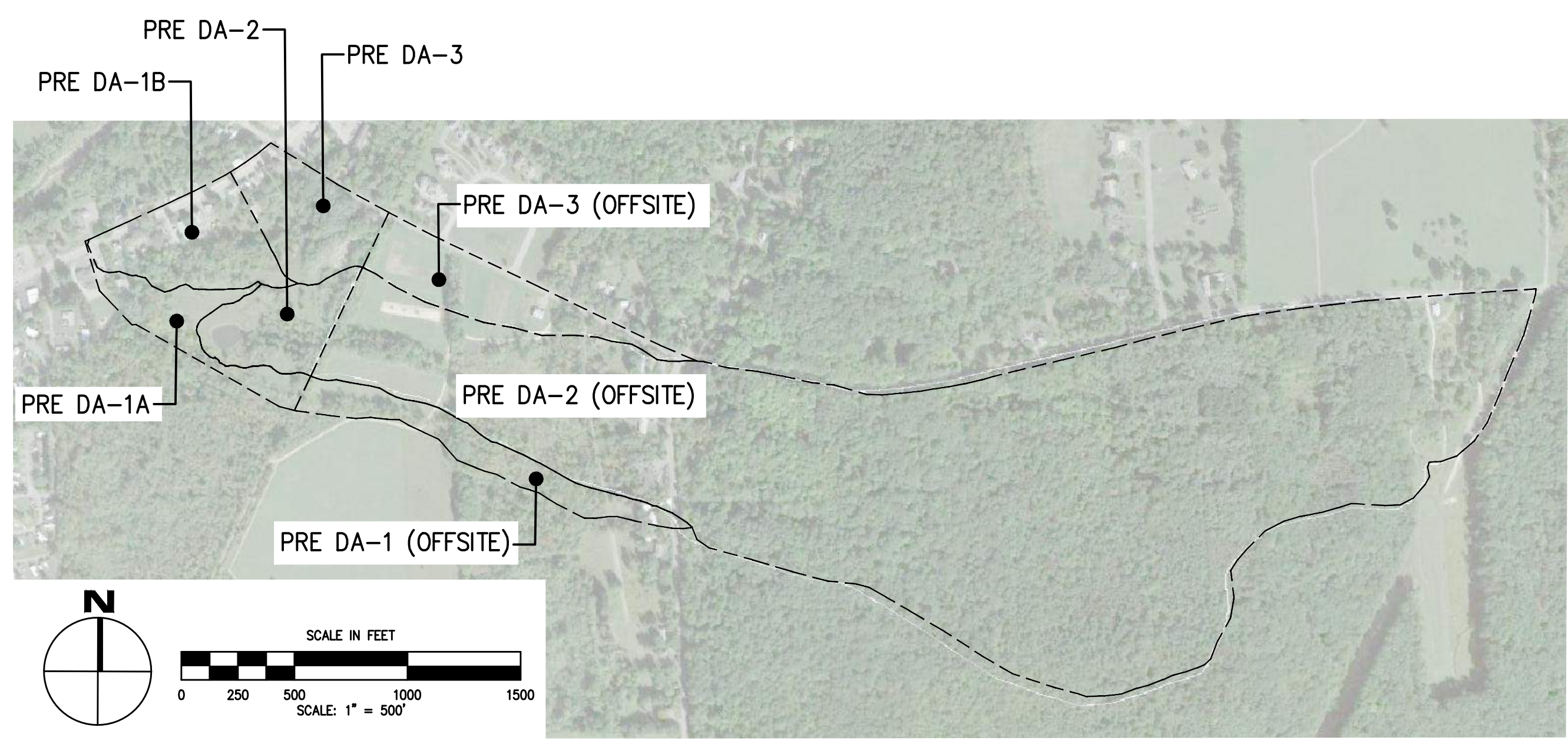
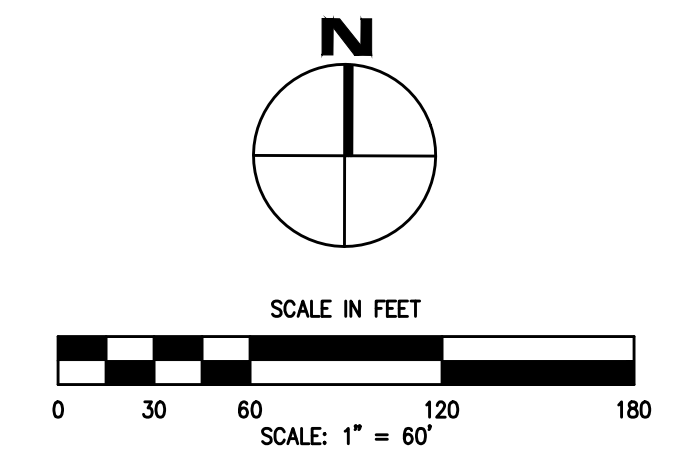
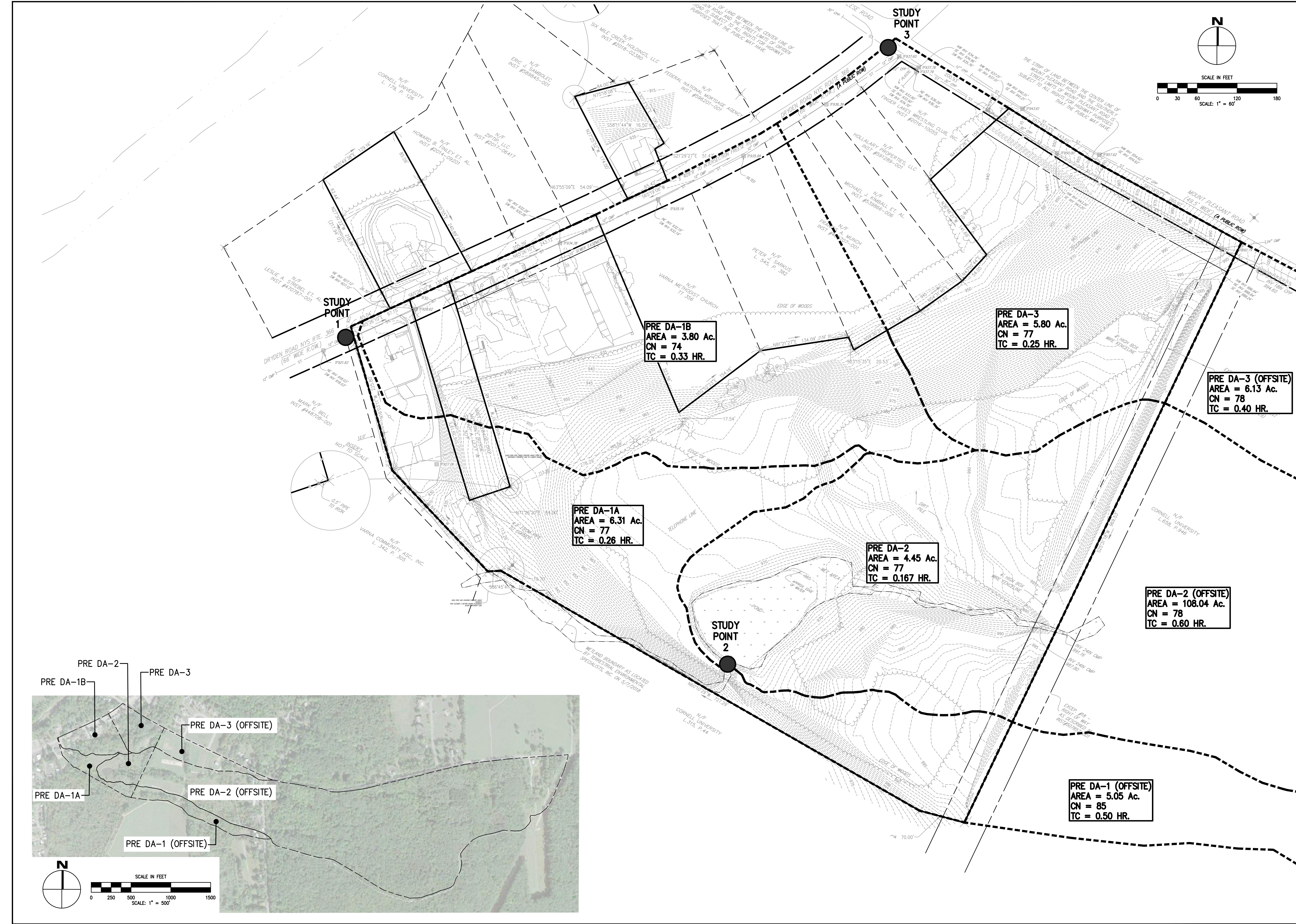

DRAWN BY: JMA	
CHECKED BY: MBK	
DATE: 3/26/2018	
SCALE: AS SHOWN	
BY:	DESCRIPTION OF REVISION:
DATE:	
<b>HUNT</b> ENGINEERS   ARCHITECTS   SURVEYORS 100 Hunt Center, Horseheads, New York 14845 Ph: 607-588-1000 F: 607-588-1800 Offices: Rochester   Horseheads   Tonawanda	
<b>PRE-EXISTING DRAINAGE AREA</b> <b>TOWNHOMES AT DRYDEN</b> <b>TRINITAS VENTURES</b> 366 DRYDEN ROAD, ITHACA, NY 14850 TOWN OF DRYDEN, TOMPKINS COUNTY, NY	
<b>L9.0</b> PROJECT NO: 3177.001	



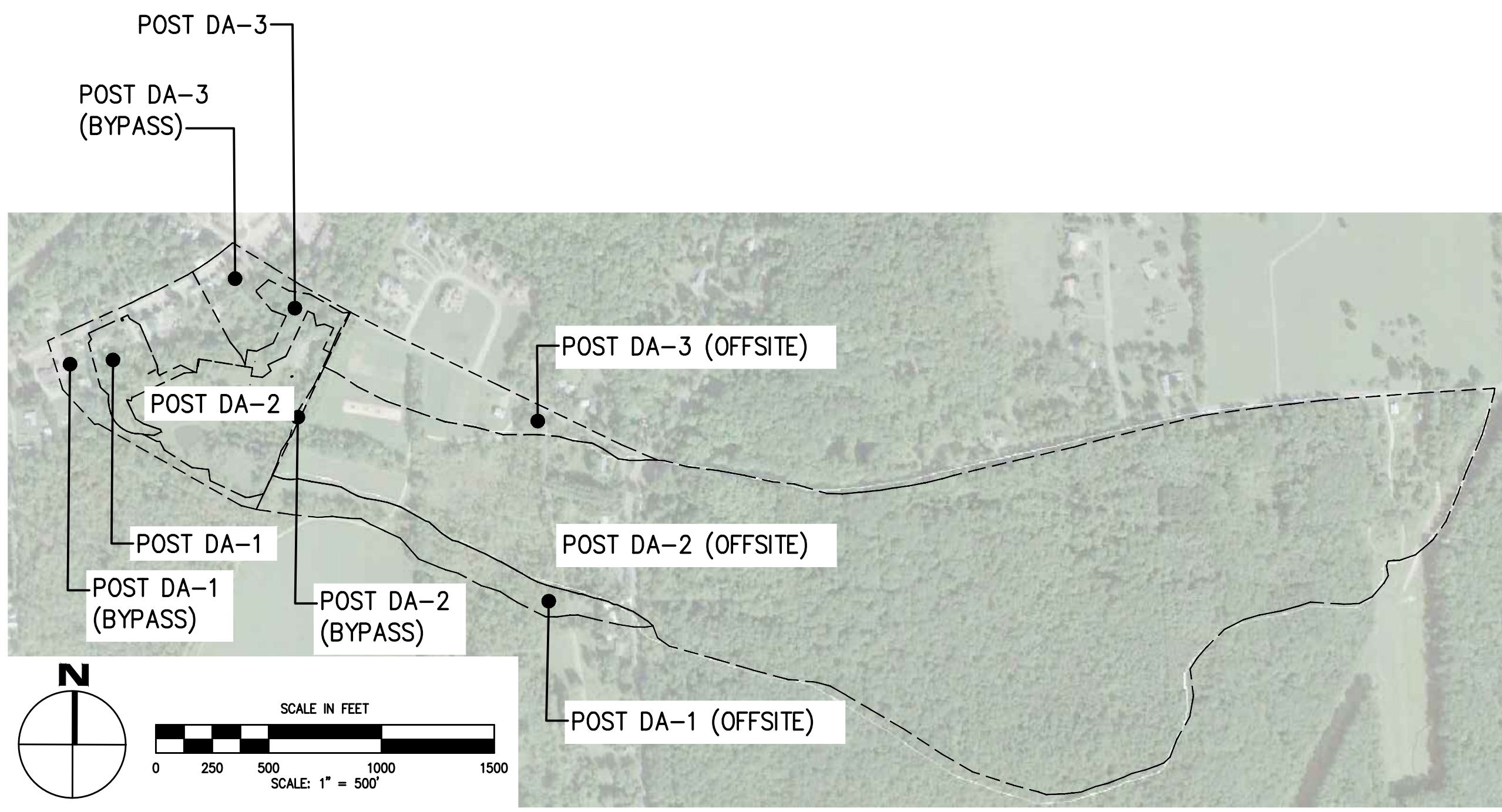
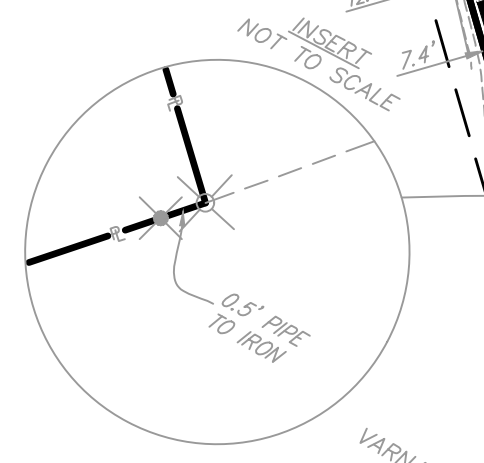
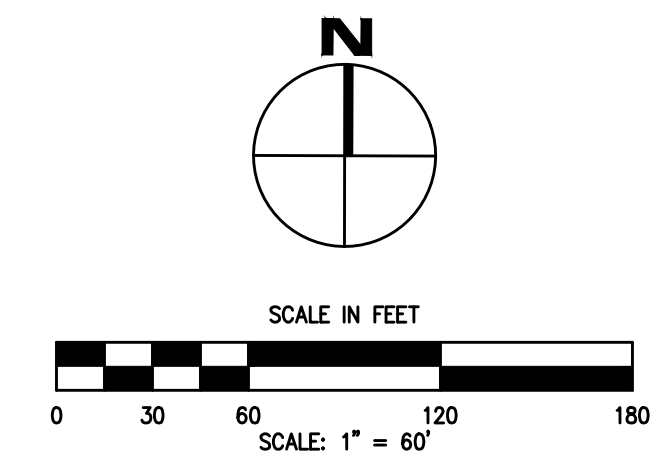
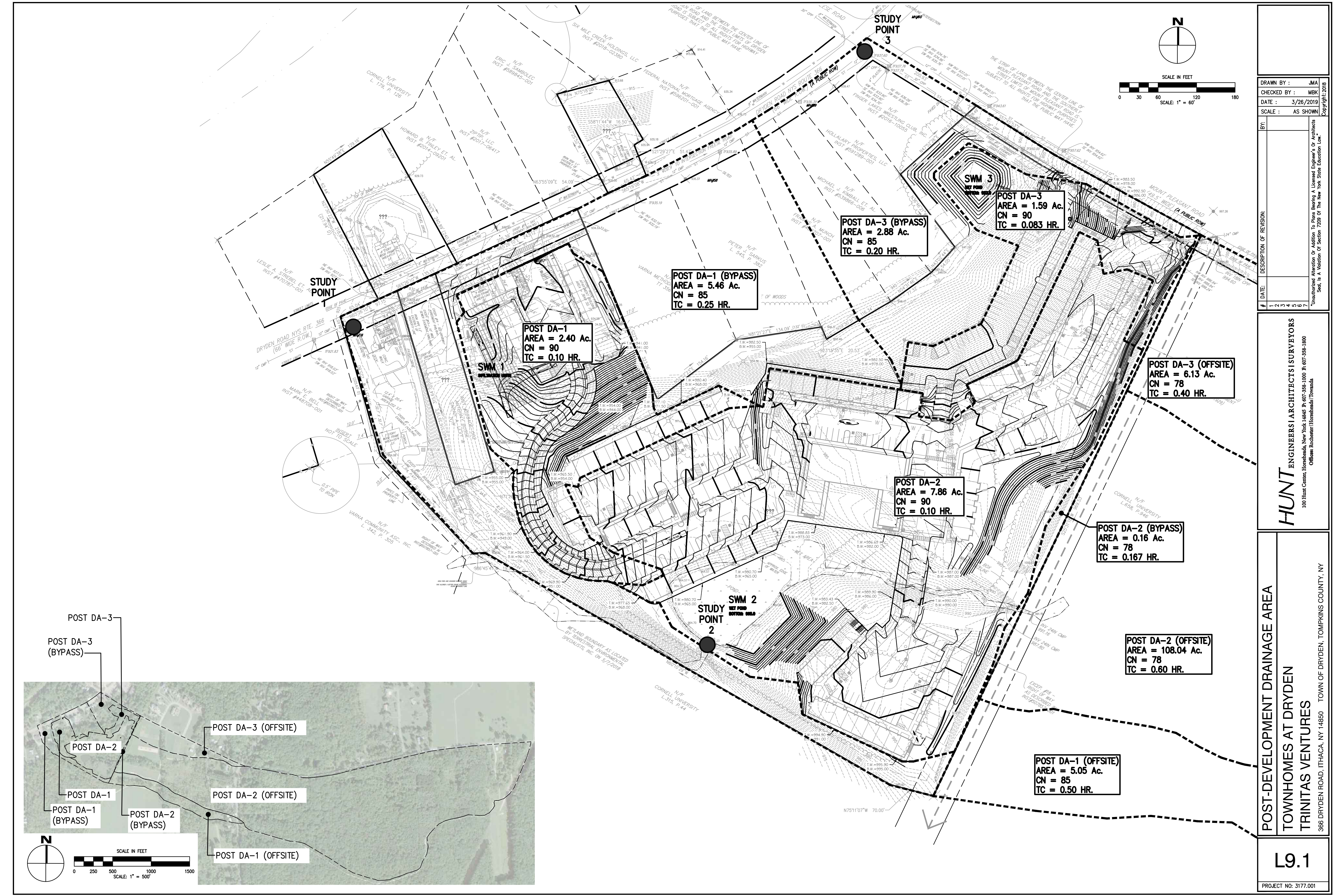

**POST DA-1**  
 AREA = 2.40 Ac.  
 CN = 90  
 TC = 0.10 HR.

**POST DA-1 (BYPASS)**  
 AREA = 5.46 Ac.  
 CN = 85  
 TC = 0.25 HR.

**POST DA-3 (BYPASS)**  
 AREA = 2.88 Ac.  
 CN = 85  
 TC = 0.20 HR.

**POST DA-3**  
 AREA = 1.59 Ac.  
 CN = 90  
 TC = 0.083 HR.

**POST DA-3 (OFFSITE)**  
 AREA = 6.13 Ac.  
 CN = 78  
 TC = 0.40 HR.

**POST DA-2**  
 AREA = 7.86 Ac.  
 CN = 90  
 TC = 0.10 HR.

**POST DA-2 (BYPASS)**  
 AREA = 0.16 Ac.  
 CN = 78  
 TC = 0.167 HR.

**POST DA-2 (OFFSITE)**  
 AREA = 108.04 Ac.  
 CN = 78  
 TC = 0.60 HR.

**POST DA-1 (OFFSITE)**  
 AREA = 5.05 Ac.  
 CN = 85  
 TC = 0.50 HR.

BY:	JMA
CHECKED BY:	MBK
DATE:	3/26/2019
SCALE:	AS SHOWN
DESCRIPTION OF REVISION:	
DATE:	

**HUNT**  
 ENGINEERS | ARCHITECTS | SURVEYORS  
 100 Hunt Center, Homebush, New York 14845 Ph: 607-588-1000 F: 607-588-1800  
 Offices: Rochester | Horseheads | Tonawanda

**POST-DEVELOPMENT DRAINAGE AREA**  
**TOWNHOMES AT DRYDEN**  
**TRINITAS VENTURES**  
 366 DRYDEN ROAD, ITHACA, NY 14850 TOWN OF DRYDEN, TOMPKINS COUNTY, NY



## **APPENDIX P**

### **Ex. Storm Sewer Capacity Calculations**



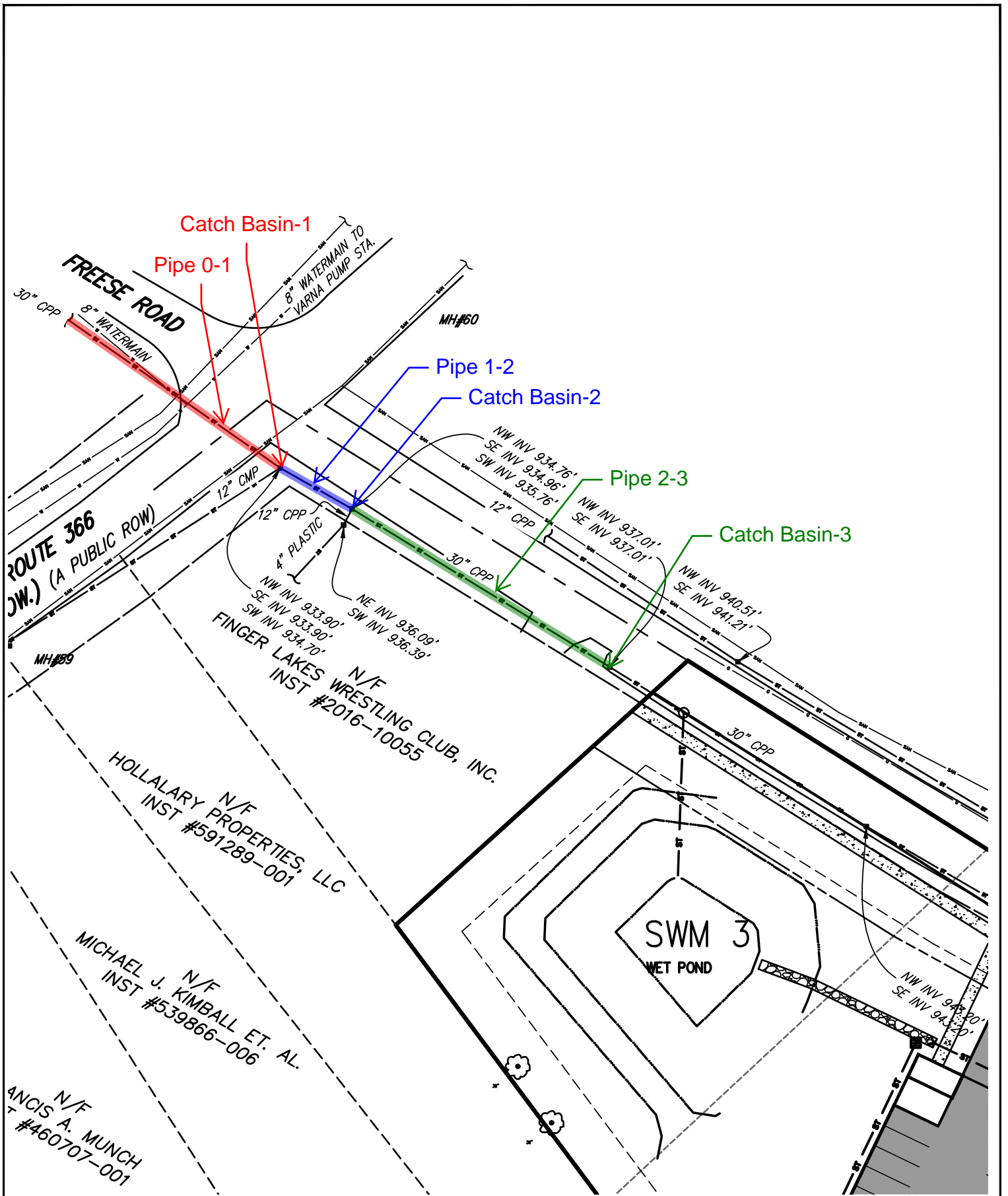

Townhomes at Varna  
 Mt. Pleasant Storm Sewer Analysis



Copyright: 2019

**HUNT** ENGINEERS | ARCHITECTS | SURVEYORS  
 4 Commercial Street, Suite 300, Rochester, NY 14614  
 P: 585-327-7950 F: 585-327-7949  
 Offices: Horseheads | Rochester | Tonawanda

CSK-01

DATE :  
 3/27/2019

PROJECT NO:  
 3177.001

**Storm Sewer C Values**

Runoff Coefficient (Impervious) =	0.95
Runoff Coefficient (Lawn/Grass) =	0.25
Runoff Coefficient (Woods/Meadow) =	0.15

**Inlet Peak Flow/Drainage Area Calculations**

Struct Label	Total Area (sf)	Total Area (Ac)	Impervious Area (Sf)	Surface Imp Area (Ac)	Grass Area (Sf)	Grass Area (Ac)	Woods (Sf)	Woods (Ac)	Weighted C Value	Flow Rate to Grate (CFS)*
Catch Basin-1	3816	0.09	2671	0.06	1145	0.026	0	0.00	0.74	0.40
Catch Basin-2	17286	0.40	3457	0.08	10371	0.238	3457	0.08	0.37	0.91
Catch Basin-3	87249	2.00	43624	1.00	34900	0.801	8725	0.20	0.59	7.31

\* Rational Method 25-Year Intensity = 6.19 in/hr

**Storm Sewer Sizing**

Pipe	Total Area (sf)	Total Area (Ac)	Pipe Size (in)	Impervious Area (Sf)	Pipe Slope	Grass Area (Sf)	Manning's n	Woods (Sf)	Weighted C Value	Full Flow Capacity (CFS)	Design Flow Rate (CFS)	Ratio of Full Flow to Design Flow
Pipe 2-3	87249	2.00	30	43624	1.67%	43624	0.013	0	0.60	53.31	7.31	0.14
Pipe 1-2	104534	0.48	30	47082	2.50%	45271	0.013	3457	0.54	65.23	8.22	0.13
Pipe 0-1	108351	2.49	30	49753	2.50%	46416	0.013	12182	0.56	65.23	8.63	0.13

**APPENDIX Q**  
**Selected Engineering Plans**



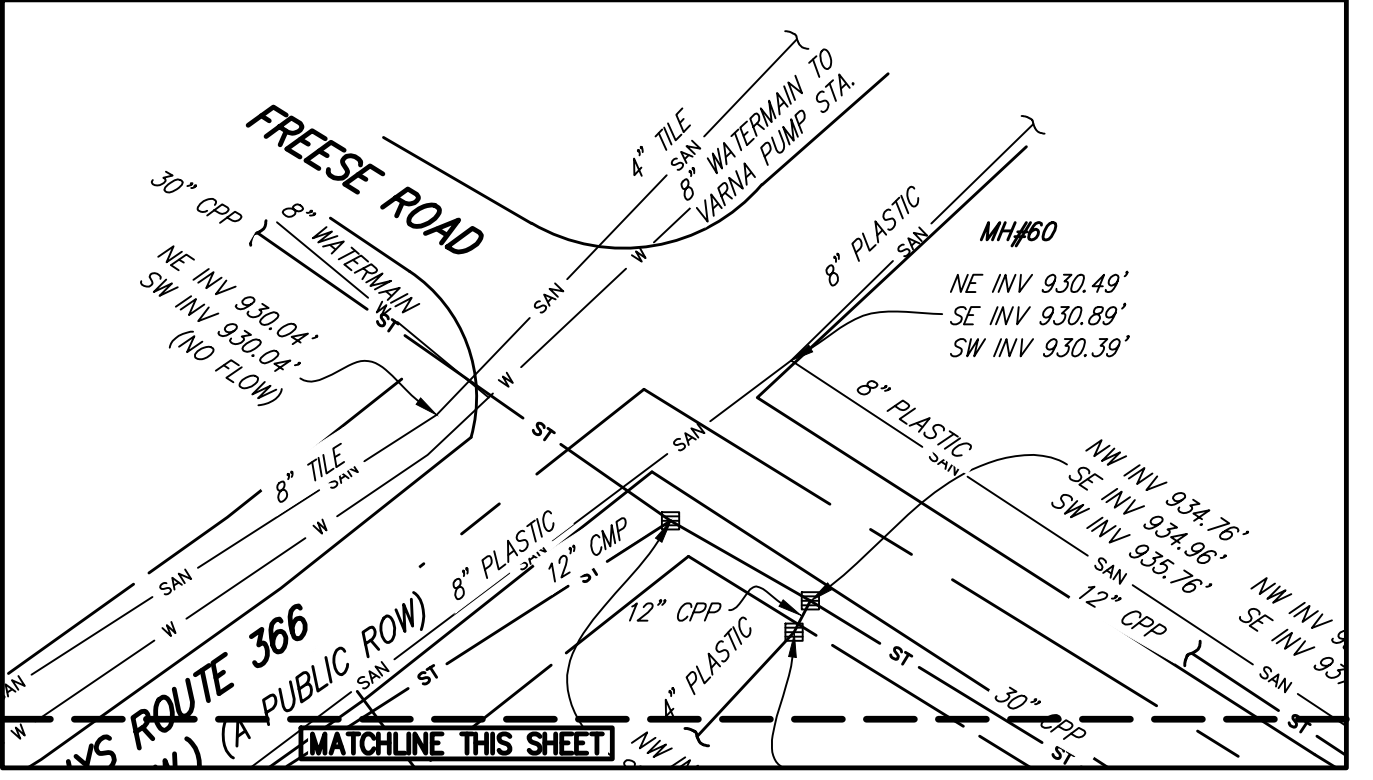
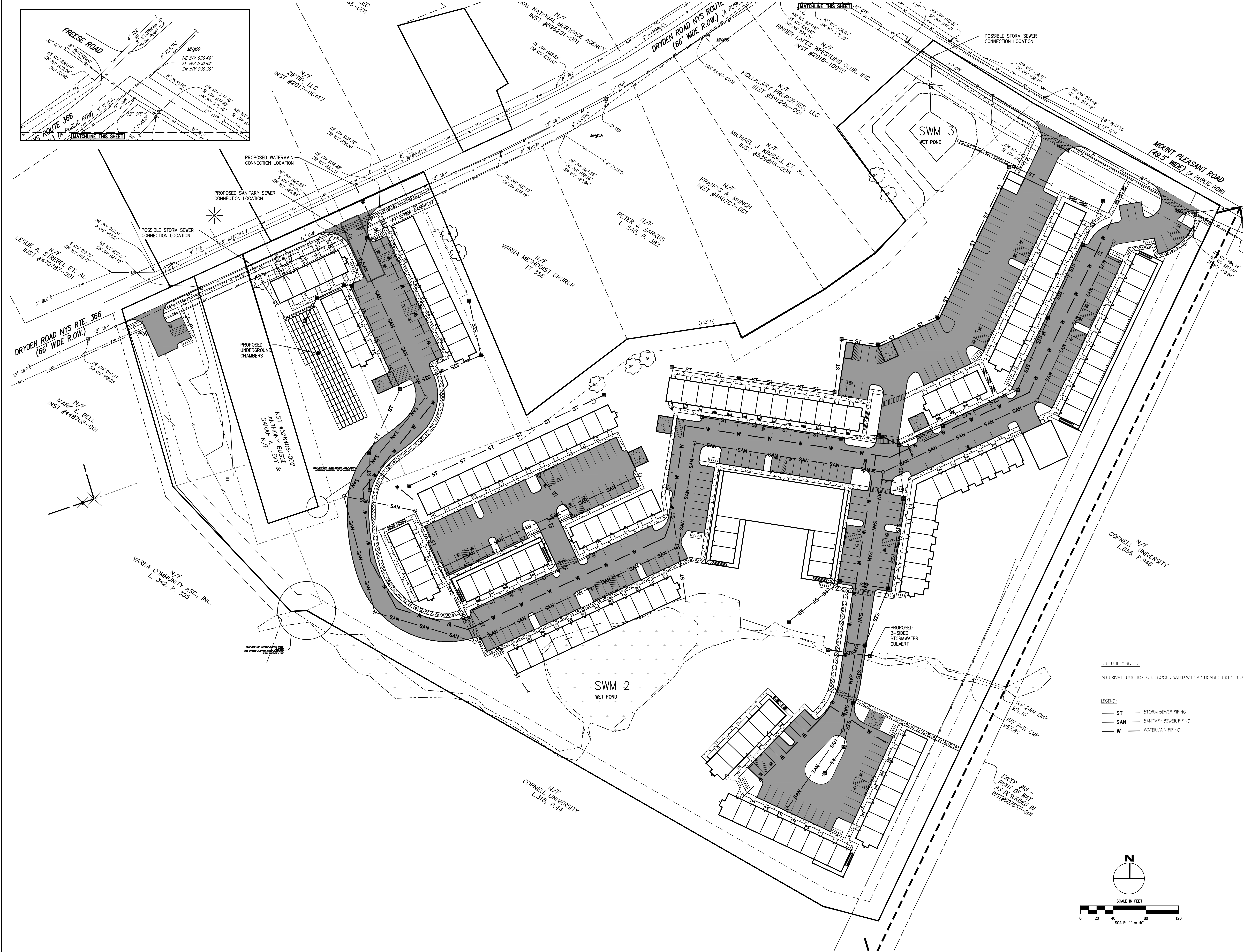

SITE UTILITY NOTES:  
 ALL PRIVATE UTILITIES TO BE COORDINATED WITH APPLICABLE UTILITY PRO

LEGEND:  
 — ST — STORM SEWER PIPING  
 — SAN — SANITARY SEWER PIPING  
 — W — WATERMAIN PIPING

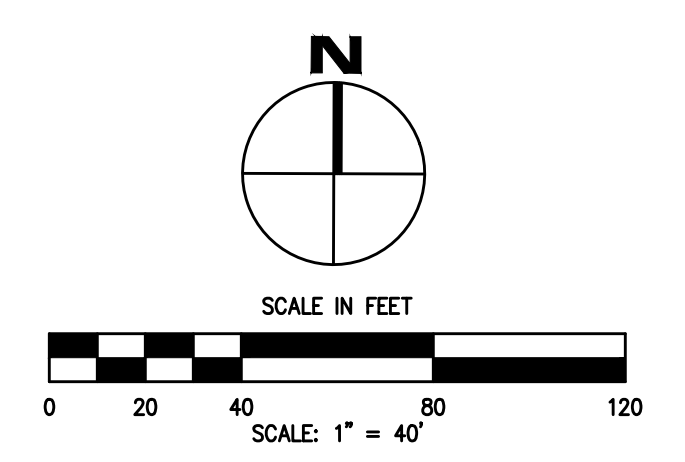

DRAWN BY: AAM CHECKED BY: MBK DATE: 06/01/2018 SCALE: AS SHOWN	
DESCRIPTION OF REVISION: 1. 07/25/18 REVISED LAYOUT FOR BOARD SUBMISSION 2. 07/25/18 REVISED LAYOUT FOR BOARD SUBMISSION	
HUNT ENGINEERS   ARCHITECTS   SURVEYORS 100 Hunt Center, Ithaca, New York 14850 P: 607-558-1000 F: 607-558-1800 Office: Rochester Ithaca/Ithaca/Townsend	
SITE UTILITY PLAN TOWNHOMES AT DRYDEN TRINITAS VENTURES 366 DRYDEN ROAD, ITHACA, NY 14850 TOWN OF VARINA, TOMPKINS COUNTY, NY	
<b>L3.0</b> PROJECT NO: 3177.001	



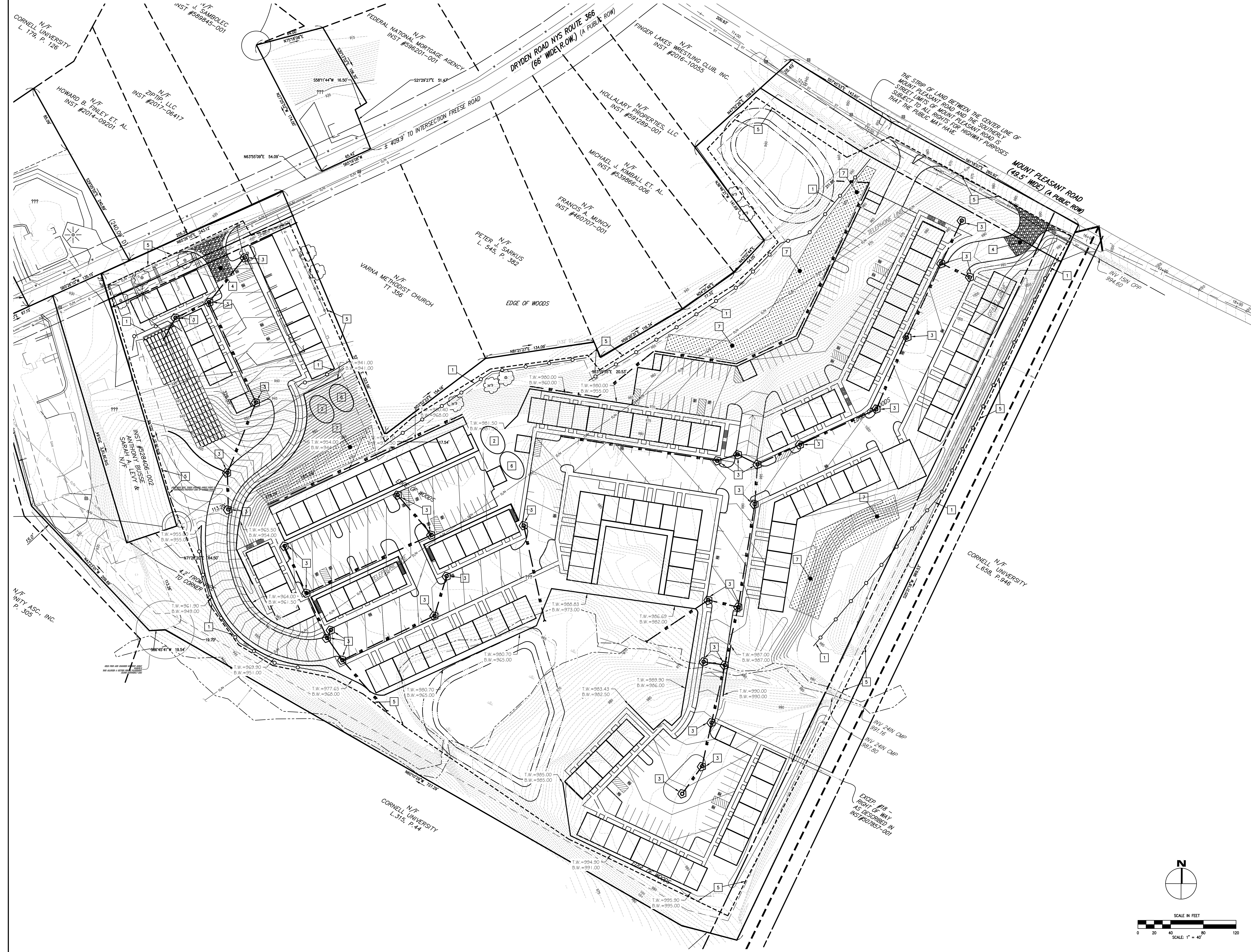

DRAWN BY:	AAM
CHECKED BY:	MBK
DATE:	6/01/2018
SCALE:	AS SHOWN
BY:	
DESCRIPTION OF REVISION:	
DATE:	

**HUNT** ENGINEERS | ARCHITECTS | SURVEYORS  
 100 Hunt Center, Horseheads, New York 14845 P: 607-588-1000 F: 607-588-1800 Office: Rochester Horseheads/Townada  
 Unauthorised alteration or addition to plans being a Licensed Engineer or Architect. See, in a  
 violation of Section 2029 of the New York State Education Law.

**E&S PLAN**  
**TOWNHOMES AT DRYDEN**  
**TRINITAS VENTURES**  
 366 DRYDEN ROAD, ITHACA, NY 14850 TOWN OF VARNA, TOMPKINS COUNTY, NY

**L6.0**  
 PROJECT NO: 3177.001

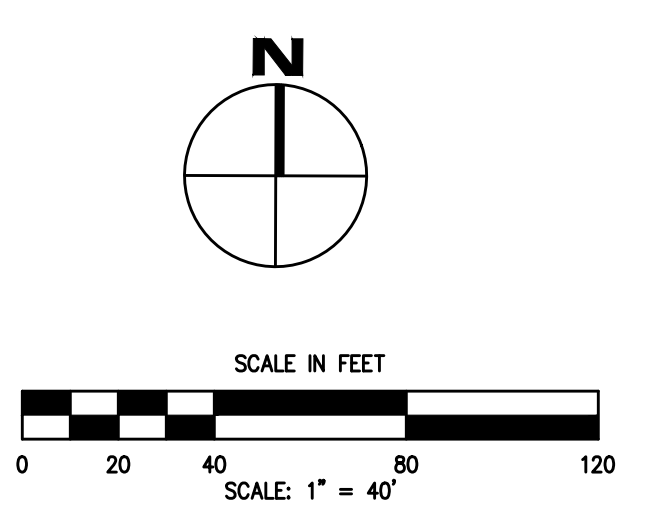



**I. GENERAL REQUIREMENTS:**

- FOR BIDDING PURPOSES, PROSPECTIVE BIDDERS SHALL MAKE THEMSELVES FAMILIAR WITH THE STORMWATER POLLUTION PREVENTION PLAN (SWPPP) THAT IS ON FILE AT THE OWNER'S OFFICE OR IT WILL OTHERWISE BE MADE AVAILABLE UPON REQUEST.
- THE STORMWATER POLLUTION PREVENTION PLAN (SWPPP) REPORT DOCUMENT, WHICH ALSO INCLUDES THE EAS PLANS (SHEETS CG-0 TO CG-1) DEFINES AND MEETS THE REQUIREMENTS OF THE NEW YORK STATE DEPARTMENT OF ENVIRONMENTAL CONSERVATION (NYSDEC) PHASE II STORMWATER REGULATIONS.
- ALL CONTRACTORS AND SUB-CONTRACTORS SHALL CERTIFY WITH THE SWPPP REPORT THAT THEY WILL IMPLEMENT AND MAINTAIN STORMWATER MANAGEMENT PRACTICES AND EROSION AND SEDIMENT CONTROL MEASURES AS SPECIFIED IN THE DOCUMENT 5 MENTIONED ABOVE.
- EROSION CONTROL MEASURES INSTALLED AND MAINTAINED BY THE SITE WORK CONTRACTOR ARE SUBJECT TO THE REVIEW AND APPROVAL BY THE NYSDEC DESIGN ENGINEER AND OWNER'S REPRESENTATIVE. IMMEDIATE ACTION BY THE CONTRACTOR SHALL BE TAKEN IF ADDITIONAL OR CORRECTIVE MEASURES ARE REQUIRED BY ANY ONE OF THESE CITED REVIEWERS. EROSION CONTROL MEASURES NOT SPECIFICALLY SHOWN ON CONTRACT DRAWINGS, SHALL BE INSTALLED AS WARRANTED BY FIELD CONDITIONS AND AS DIRECTED BY THE AFOREMENTIONED REVIEWERS.
- AS DESIGN ENGINEER, OUR OFFICE HAS NOTIFIED THE OWNER OF THE INSPECTION REQUIREMENTS UNDER THE GENERAL PERMIT. DISTURBANCES OF ONE ACRE OR GREATER REQUIRE THAT THE OWNER FILE A NOTICE OF INTENT AND A SWPPP WITH THE NYSDEC UNDER STATE POLLUTANT DISCHARGE ELIMINATION SYSTEM (SPDES). THE REGULATIONS REQUIRE THAT A LICENSED PROFESSIONAL COMPLETE A WEEKLY INSPECTION THROUGHOUT THE PERIOD OF LAND DISTURBANCE OR TWO (2) INSPECTIONS EVERY WEEK IF GREATER THAN 5 ACRES IS DISTURBED AT ANY ONE TIME.

**II. EROSION & SEDIMENT POLLUTION CONTROL (E & SPC) GUIDELINES:**

- THE CONTRACTOR SHALL BE RESPONSIBLE FOR IMPLEMENTING EROSION AND SEDIMENT CONTROL TO PROTECT DOWNSTREAM WATER BODIES.
- THE CONTRACTOR SHALL BE RESPONSIBLE FOR CONSTRUCTION CONTROL AND MAINTENANCE OF SOIL EROSION AND SEDIMENT CONTROL FACILITIES TO ENSURE PROPER FUNCTIONING OF SAID FACILITIES DURING CONSTRUCTION.
- AFTER THE PROJECT HAS BEEN COMPLETED, THE CONTRACTOR SHALL HAVE THE RESPONSIBILITY FOR ENSURING THAT ALL TEMPORARY SOIL EROSION AND SEDIMENT CONTROL MEASURES HAVE BEEN REMOVED OR REPLACED BY PERMANENT CONTROLS.
- ANY DISTURBED AREAS THAT WILL BE LEFT EXPOSED FOR MORE THAN FIVE (5) DAYS, AND NOT SUBJECT TO CONSTRUCTION TRAFFIC, WILL IMMEDIATELY RECEIVE A TEMPORARY SEEDING. IF THE SEASON PREVENTS THE ESTABLISHMENT OF A TEMPORARY COVER, THE DISTURBED AREAS WILL BE MULCHED WITH STRAW OR EQUIVALENT MATERIAL AT A RATE OF 2.5 - 3.0 TONS PER ACRE, ACCORDING TO STATE STANDARDS.
- PERMANENT VEGETATION TO BE SEEDED OR SODDED ON ALL EXPOSED AREAS WITHIN FIVE (5) DAYS AFTER FINAL GRADING. MULCH AS NECESSARY FOR SEED PROTECTION AND ESTABLISHMENT. LIME AND FERTILIZE SEED BED PRIOR TO PERMANENT SEEDING.
- EROSION AND SEDIMENT POLLUTION CONTROL FACILITIES AND PRACTICES, UTILIZED IN THE CONSTRUCTION OF THE PROJECT, SHALL BE CONSISTENT WITH THE LATEST VERSIONS OF THE NEW YORK STATE STANDARDS AND SPECIFICATIONS FOR EROSION AND SEDIMENT CONTROL, NEW YORK STATE STORMWATER MANAGEMENT DESIGN MANUAL AND THE NEW YORK STATE SPDES GENERAL PERMIT FOR STORMWATER DISCHARGES.
- NATURAL VEGETATION SHALL BE RETAINED, PROTECTED, AND SUPPLEMENTED, AS FEASIBLE PRIOR TO AND DURING CONSTRUCTION.
- CUT AND FILL SLOPES SHALL BE BROUGHT TO FINAL PROPOSED GRADES AS SOON AS POSSIBLE IN THE CONSTRUCTION SEQUENCES, AND SEEDED AND MULCHED IMMEDIATELY.
- EROSION AND SEDIMENT POLLUTION CONTROL FACILITIES (SILT SOCK, INLET PROTECTION, STABILIZED CONSTRUCTION ENTRANCES AND ALL OTHER ACCEPTABLE FACILITIES) SHALL BE MAINTAINED THROUGHOUT CONSTRUCTION UNTIL COMPLETE SITE STABILIZATION.
- HEAVY CONSTRUCTION EQUIPMENT SHALL BE KEPT AS CLOSE TO THE WORK AREA AS PRACTICED TO MINIMIZE DISTURBANCE OF SOIL ALREADY STABILIZED OR UNDISTURBED.
- TOPSOIL AND OTHER SOIL REMOVED DURING CONSTRUCTION SHALL BE STOCKPILED IN A SUITABLE LOCATION CLEAR FROM ANY STORMWATER DRAINAGE COURSES. STOCKPILES WHICH ARE INACTIVE FOR MORE THAN 5 DAYS SHALL BE SEED.
- VEGETATIVE STABILIZATION SHALL BE PERIODICALLY INSPECTED FOR SUFFICIENT GROWTH AND PROGRESS. AREAS NOT RESPONDING SHALL BE PROMPTLY RESEED AND REMULCHED AS SOON AS POSSIBLE. AREAS SHOWING SIGNS OF EROSION PRIOR TO STABILIZATION SHALL BE GRADED, RESEED, AND REMULCHED AS SOON AS POSSIBLE. SOIL OR EROSION CONTROL FABRIC SHALL BE UTILIZED WHERE ADEQUATE STABILIZATION IS NOT OCCURRING.
- ALL SOIL EROSION AND SEDIMENT CONTROL MEASURES SHALL BE INSTALLED BEFORE BEGINNING EARTH MOVING ACTIVITIES, OR IN THEIR PROPER SEQUENCE, AND MAINTAINED UNTIL PERMANENT PROTECTION IS ESTABLISHED.
- A STABILIZED CONSTRUCTION ENTRANCE PAD OF 1' 5" TO 2" CLEAN SOIL WILL BE PLACED AT ALL CONSTRUCTION DRIVEWAYS IMMEDIATELY AFTER INITIAL SITE DISTURBANCE.
- THE APPLICATION OF TOPSOIL, LIMING, FERTILIZING, SEEDING, AND MULCHING FOR DISTURBED AREAS SHALL BE CONSISTENT WITH THE STANDARD GENERAL PRACTICES FOR CONSTRUCTION.
- IMMEDIATELY FOLLOWING INITIAL DISTURBANCES OF BROAD GRADING, ALL CRITICAL AREAS SUBJECT TO EROSION (I.E., STEEP SLOPES AND ROADWAY EMBANKMENTS, ETC.) WILL RECEIVE A TEMPORARY SEEDING IN COMBINATION WITH STRAW MULCH OR A SUITABLE EQUIVALENT, AT A RATE OF 2.5 - 3.0 TONS PER ACRE.
- AT THE TIME WHEN SITE PREPARATION FOR PERMANENT VEGETATIVE STABILIZATION IS TO BE ESTABLISHED, ANY SOIL THAT WILL NOT PROVIDE A SUITABLE ENVIRONMENT TO SUPPORT ADEQUATE VEGETATIVE GROUND COVER SHALL BE REMOVED OR TREATED IN SUCH A WAY THAT WILL PERMANENTLY ADJUST THE SOIL CONDITIONS AND RENDER IT SUITABLE FOR VEGETATIVE GROUND COVER.
- IF THE REMOVAL OR TREATMENT OF THE SOIL WILL NOT PROVIDE SUITABLE CONDITIONS, NON-VEGETATIVE MEANS OF PERMANENT GROUND STABILIZATION WILL HAVE TO BE EMPLOYED.
- IT SHALL BE THE CONTRACTORS RESPONSIBILITY TO MAINTAIN EROSION AND SEDIMENT CONTROL MEASURES UNTIL ALL AREAS HAVE BEEN PERMANENTLY STABILIZED.

**III. MAINTENANCE AND REPAIR OF EROSION AND SEDIMENT FACILITIES**

- PROPER MAINTENANCE AND REPAIR OF EROSION AND SEDIMENT CONTROL FACILITIES ARE NECESSARY TO THE EFFECTIVENESS OF THE EROSION AND SEDIMENT POLLUTION CONTROL FACILITIES.
- DISTURBED GROUND SURFACES SHALL BE SPRINKLED WITH WATER AND/OR CARBON CHLORIDE, AS NEEDED, TO LIMIT THE FORMATION AND MIGRATION OF AIRBORNE DUST.
- OPERATIONAL MEASURES SHALL BE EMPLOYED DURING CONSTRUCTION TO PREVENT THE SPILLS OF FUELS AND LUBRICANTS. IF A SPILL OCCURS, IT SHALL BE CONTROLLED IMMEDIATELY TO PREVENT ITS ENTRY INTO OFF-SITE AREAS INCLUDING ADJACENT STORM SEWER.
- ANY TEMPORARY EROSION CONTROL FACILITY SHALL REMAIN FUNCTIONAL UNTIL VEGETATIVE COVER IS SUFFICIENTLY ESTABLISHED WITHIN THE RESPECTIVE TRIBUTARY DRAINAGE AREA.
- ANY DEBRIS ACCUMULATED IN EROSION AND SEDIMENT CONTROL FACILITIES SHALL BE REMOVED AND PROPERLY DISPOSED OF. THESE FACILITIES SHALL BE CHECKED DAILY AND AFTER RAINFALL EVENTS, AND REALIGNED AS NEEDED. SEDIMENT SHALL BE REMOVED WHEN IT REACHES THE FOLLOWING DEPTHS:  
SILT SOCK - 1/2 HEIGHT (6 INCHES)
- NOTE: DISTURBED AREAS SHALL BE CONSIDERED AS PERMANENTLY STABILIZED WHEN A MINIMUM COVER OF 80% HAS BEEN ESTABLISHED.
- ANY EROSION AND SEDIMENT CONTROL DEVICES THAT ARE NOTED AS DEFICIENT BY AN INSPECTOR OR NYSDEC STAFF SHALL BE REPAIRED OR REPLACED WITHIN ONE WEEKS TIME.

**IV. SOIL RESTORATION REQUIREMENTS**

- AERATION AND THE APPLICATION OF 6 INCHES OF TOPSOIL IS REQUIRED IN ANY PROPOSED LAWN AREA WHERE TOPSOIL HAS BEEN DISTURBED.
- FULL SOIL RESTORATION IS REQUIRED IN HEAVY TRAFFIC AREAS ON SITE, ESPECIALLY BETWEEN 5' AND 25' FEET AROUND THE PROPOSED BUILDING, BUT NOT WITHIN A 5' FOOT PERIMETER AROUND FOUNDATION WALLS. RESTORATION IS ALSO REQUIRED ON REDEVELOPMENT PROJECTS IN AREAS WHERE EXISTING IMPERVIOUS AREA WILL BE CONVERTED TO PERVIOUS AREA.
- FULL SOIL RESTORATION REQUIREMENTS ARE AS FOLLOWS:
  - SOIL RESTORATION IS TO TAKE PLACE DURING PERIODS OF RELATIVELY LOW TO MODERATE SUBSOIL MOISTURE, FOLLOWING ROUGH GRADING OF THE DISTURBED SUBSOILS.
  - APPLY 3 INCHES OF COMPOST OVER SUBSOIL.
  - TILL COMPOST INTO SUBSOIL TO A DEPTH OF AT LEAST 12 INCHES USING A CAT-MOUNTED RIPPER, TRACTOR-MOUNTED DISC, OR TILLER, MIXING, AND CIRCULATING AIR AND COMPOST INTO SUBSOILS.
  - ROCK-PICK UNTIL UPLIFTED STONEROCK MATERIALS OF FOUR INCHES AND LARGER SIZE ARE CLEANED OFF THE SITE.
  - APPLY TOPSOIL TO A DEPTH OF 6 INCHES.
  - VEGETATE AS SPECIFIED ON PLANS.
- AT THE END OF THE PROJECT AN INSPECTOR SHOULD BE ABLE TO PUSH A 3/8 INCH METAL BAR 12 INCHES INTO THE SOIL JUST WITH BODY WEIGHT.
- TILLING SHOULD NOT BE PERFORMED WITHIN THE DRIP LINE OF ANY EXISTING TREES OR OVER UTILITY INSTALLATIONS THAT ARE WITHIN 24 INCHES OF THE SURFACE.
- ADDITIONAL INFORMATION AND GUIDANCE MAY BE FOUND IN 'DEEP-RIPPING AND DECOMPACTION' PUBLISHED BY NYSDEC DIVISION OF WATER 2008.

**V. MULCHING AND SEEDING REQUIREMENTS**

- SEEDBED PREPARATION:
  - APPLY LIMESTONE EQUIVALENT TO 50 PERCENT (50%) CALCIUM PLUS MAGNESIUM OXIDES AT A RATE OF 90 POUNDS PER 1,000 SQUARE FEET. APPLY FERTILIZER AT A RATE OF 600 POUNDS PER ACRE OR 14 POUNDS PER 1,000 SQUARE FEET USING 10:20:10 OR EQUIVALENT.
  - WORK LIME AND FERTILIZER INTO SOIL AS NEARLY AS PRACTICAL TO A DEPTH OF 4 INCHES WITH A DISC, SPRINGTOOTH HARROW OR OTHER SUITABLE EQUIPMENT. THE FINAL HARROWING OR DISCING OPERATION SHOULD BE ON THE GENERAL CONTOUR, CONTINUE TILLAGE UNTIL A REASONABLY UNIFORM SEEDBED IS PREPARED.
  - INSPECT SEEDBED JUST BEFORE SEEDING. IF TRAFFIC HAS LEFT THE SOIL COMPACT, THE AREA MUST BE RETILLED AS ABOVE.
- SEEDING:
  - APPLY LAWN MIX AT A RATE (SEE SPECIFICATIONS)
  - APPLY SEED WITH MECHANICAL SEEDER. OPTIMUM SEEDING DEPTH IS ONE INCH (EXCEPT SANDY SOILS, 2 INCHES)
  - WHERE FEASIBLE, EXCEPT WHERE EITHER A CULTIPAKER TYPE SEEDER OR HYDROSEEDER IS USED, THE SEEDBED SHALL BE FIRMED FOLLOWING SEEDING OPERATIONS WITH A ROLLER, OR LIGHT DRAG. SEEDING OPERATIONS SHOULD BE ON THE CONTOUR.
- MULCHING
  - MULCH MATERIALS SHALL BE UNROTTED SALT HAY OR SMALL GRAIN STRAW AT A RATE OF 2-1/2 TO 3 TONS PER ACRE, OR 70 TO 90 POUNDS PER 1,000 SQUARE FEET. MULCH SHOULD NOT BE GROUND OR CHOPPED INTO SHORT PIECES.
  - SPREAD UNIFORMLY BY HAND OR MECHANICALLY SO THAT APPROXIMATELY 75 PERCENT TO 95 PERCENT OF THE SOIL SURFACE WILL BE COVERED.
  - MULCH ANCHORING SHALL BE ACCOMPLISHED IMMEDIATELY AFTER PLACEMENT TO MINIMIZE LOSS BY WIND OR WATER. MULCHING NETTINGS - STAPLE, LITE OR COTTON NETTINGS TO THE SOIL SURFACE. USE A DEGRADABLE NETTING IN AREAS TO BE MOWED.
- PERMANENT SEEDING TO BE INSTALLED PER MANUFACTURERS SPECIFICATIONS.

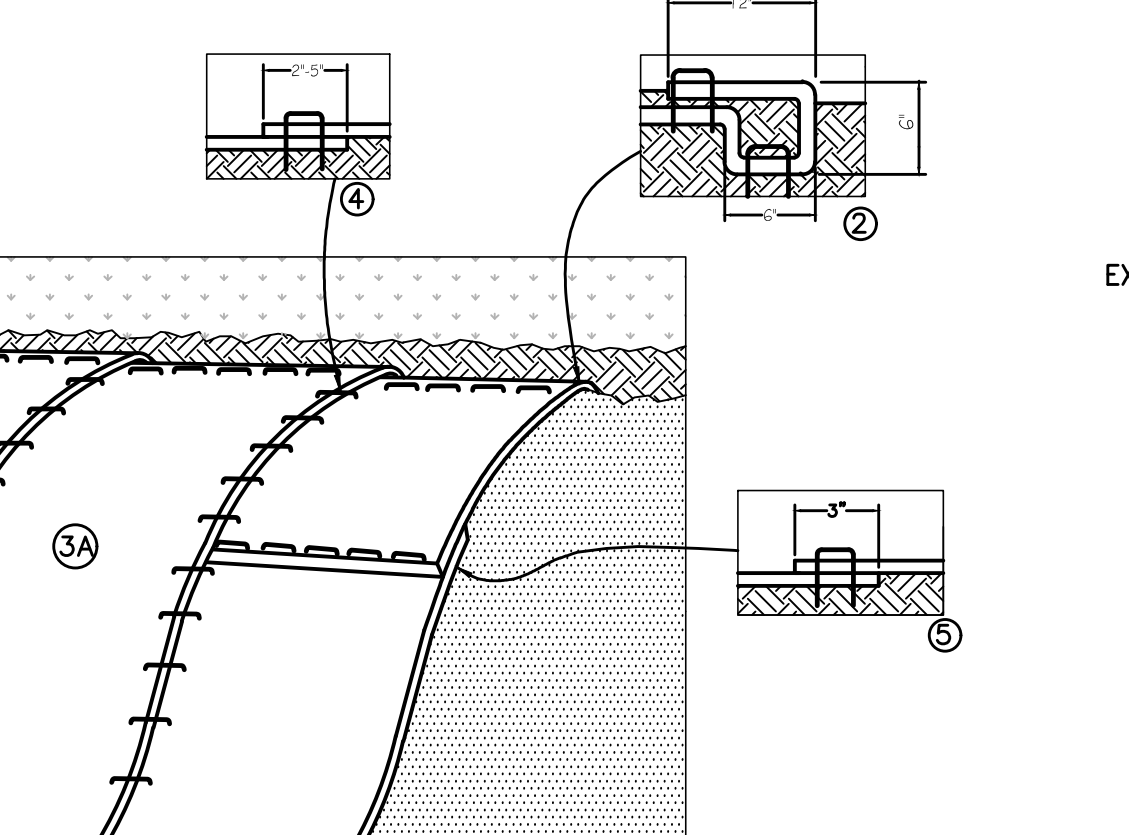

- PREPARE SOIL BEFORE INSTALLING ROLLED EROSION CONTROL PRODUCTS (RECPS) INCLUDING ANY NECESSARY APPLICATION OF LIME, FERTILIZER, AND SEED.
- BEGIN AT THE TOP OF THE SLOPE BY ANCHORING THE RECPS IN A 6" DEEP X 6" WIDE TRENCH WITH APPROXIMATELY 1/2" OF RECPS EXTENDED BEYOND THE UP-SLOPE PORTION OF THE TRENCH. WITH A ROW OF STAPLES PLACED APPROXIMATELY 12" APART IN THE BOTTOM OF THE TRENCH, BACKFILL AND COMPACT THE TRENCH AFTER STAPLING. APPLY SEED TO COMPACTED SOIL AND FOLD REMAINING 1/2" PORTION OF RECPS BACK OVER SEED AND COMPACTED SOIL. SECURE RECPS OVER COMPACTED SOIL WITH A ROW OF STAPLES/STAKES SPACED APPROXIMATELY 12" APART ACROSS THE WIDTH OF THE RECPS.
- ROLL THE RECPS DOWN OR (B) HORIZONTALLY ACROSS THE SLOPE. RECPS WILL UNROLL WITH APPROPRIATE SIDE AGAINST THE SOIL SURFACE. ALL RECPS MUST BE SECURELY FASTENED TO SOIL SURFACE BY PLACING STAPLES/STAKES IN APPROPRIATE LOCATION AS SHOWN IN THE STAPLE PATTERN GUIDE. WHEN USING THE DOT SYSTEM, STAPLES/STAKES SHOULD BE PLACED THROUGH EACH OF THE COLORED DOTS CORRESPONDING TO THE APPROPRIATE STAPLE PATTERN.
- THE EDGES OF PARALLEL RECPS MUST BE STAPLED WITH APPROXIMATELY 2" 5" OVERLAP DEPENDING ON RECPS TYPE.
- CONSECUTIVE RECPS SPICED DOWN THE SLOPE MUST BE PLACED END OVER END (SHINGLE STYLE) WITH AN APPROXIMATE 3" OVERLAP. STAPLE THROUGH OVERLAPPED AREA, APPROXIMATELY 12" APART ACROSS ENTIRE RECPS WIDTH.
- IN LOOSE SOIL CONDITIONS, THE EDGE OF STAPLE OR STAKE LENGTH GREATER THAN 6" MAY BE NECESSARY TO PROPERLY ANCHOR THE RECPS.

SLOPE INSTALLATION

**VI. SEQUENCE OF CONSTRUCTION**

THE FOLLOWING ARE STEPS REGARDING THE CONSTRUCTION AND INSTALLATION OF VARIOUS PROJECT COMPONENTS THAT WILL ASSIST IN THE CONTROL OF EROSION AND SEDIMENT CONTROL:

- CONTRACTOR SHALL REVIEW AND SIGN/CERTIFY THE SWPPP DOCUMENTATION. A COPY OF THE CERTIFIED SWPPP SHALL BE RETAINED AT THE PROJECT SITE THROUGHOUT THE DURATION OF THE PROJECT.
- INSTALL STABILIZED CONSTRUCTION ENTRANCE AND PERIMETER PROTECTION MEASURES (SILT SOCK, STORM INLET PROTECTION, ETC.).
- ROUGH GRADE SITE WITH EROSION CONTROL MEASURES AS SHOWN ON PLANS.
- TEMPORARILY STABILIZE ALL DISTURBED AREAS.
- INSTALL UTILITIES AND STORM CONVEYANCE STRUCTURES, FACILITIES AND PIPES. PROVIDE STORM INLET PROTECTION AS INDICATED.
- INSTALL PAVEMENT, BUILDINGS AND ALL OTHER PROPOSED SITE IMPROVEMENTS.
- PROVIDE PERMANENT VEGETATION ON ALL DISTURBED AREAS.
- REMOVE ALL TEMPORARY EROSION AND SEDIMENT CONTROL ONCE 80% STABILIZATION HAS BEEN ACHIEVED.
- CONTRACTOR SHALL NOTIFY PROJECT DESIGN ENGINEER/ARCHITECT THAT SITE STABILIZATION IS COMPLETED, THE SWPPP IS TO BE REMOVED FROM THE SITE AND NOTICE OF TERMINATION SHOULD BE CONSIDERED.

NOTE: AT NO POINT DURING CONSTRUCTION SHALL GREATER THAN 5 ACRES OF THE PROJECT SITE BE DISTURBED AT ANY ONE TIME WITHOUT PRIOR APPROVAL OF A 5-ACRE WAIVER FROM THE NYSDEC.

**VII. TOPSOIL**

- ON-SITE TOPSOIL:
  - EXCAVATED AND REUSED MATERIAL.
  - GRADED.
  - FREE OF ROOTS, ROCKS LARGER THAN 1/2 INCH, SUBSOIL, DEBRIS, LARGE WEEDS AND FOREIGN MATTER.
    - SCREENING - SINGLE SCREENED.
    - CONFORMING TO ASTM D2487.
- IMPORTED TOPSOIL
  - IMPORTED FROM ROW.
  - FIABLE LOAM.
  - REASONABLY FREE OF ROOTS, ROCKS LARGER THAN 1/2 INCH, SUBSOIL, DEBRIS, LARGE WEEDS, AND FOREIGN MATTER.
    - SCREENING - DOUBLE SCREENED.
    - ACIDITY RANGE (PH) OF 5.5 TO 7.5
    - CONTAINING MINIMUM OF 4 PERCENT AND MAXIMUM OF 25 PERCENT INORGANIC MATTER.
    - CONFORMING TO ASTM D2487.
    - LIMIT DECAYING MATTER TO 5 PERCENT OF TOTAL CONTENT BY VOLUME.

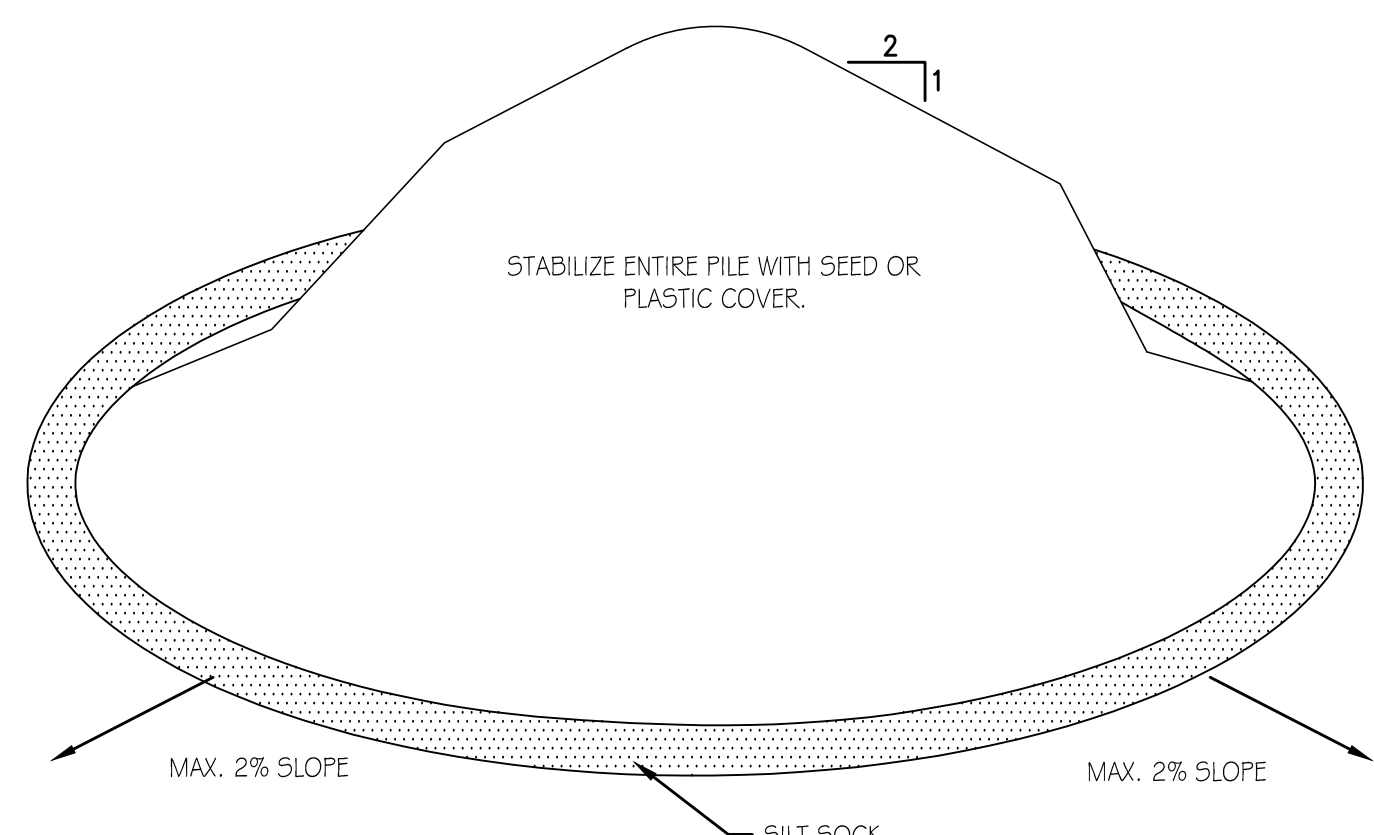

- SOIL STOCKPILING NOTES:**
- AREA CHOSEN FOR STOCKPILING OPERATIONS SHALL BE DRY AND STABLE.
  - MAXIMUM SLOPE OF STOCKPILE SHALL BE 1:2.
  - UPON COMPLETION OF SOIL STOCKPILING, EACH PILE SHALL BE SURROUNDED WITH SILT SOCK AND THEN STABILIZED WITH SEED OR SECURED IMPERVIOUS COVER.
  - SEE SILT SOCK INSTALLATION DETAIL THIS SHEET.

**5 SOIL STOCKPILE DETAIL**  
SCALE: NOT TO SCALE

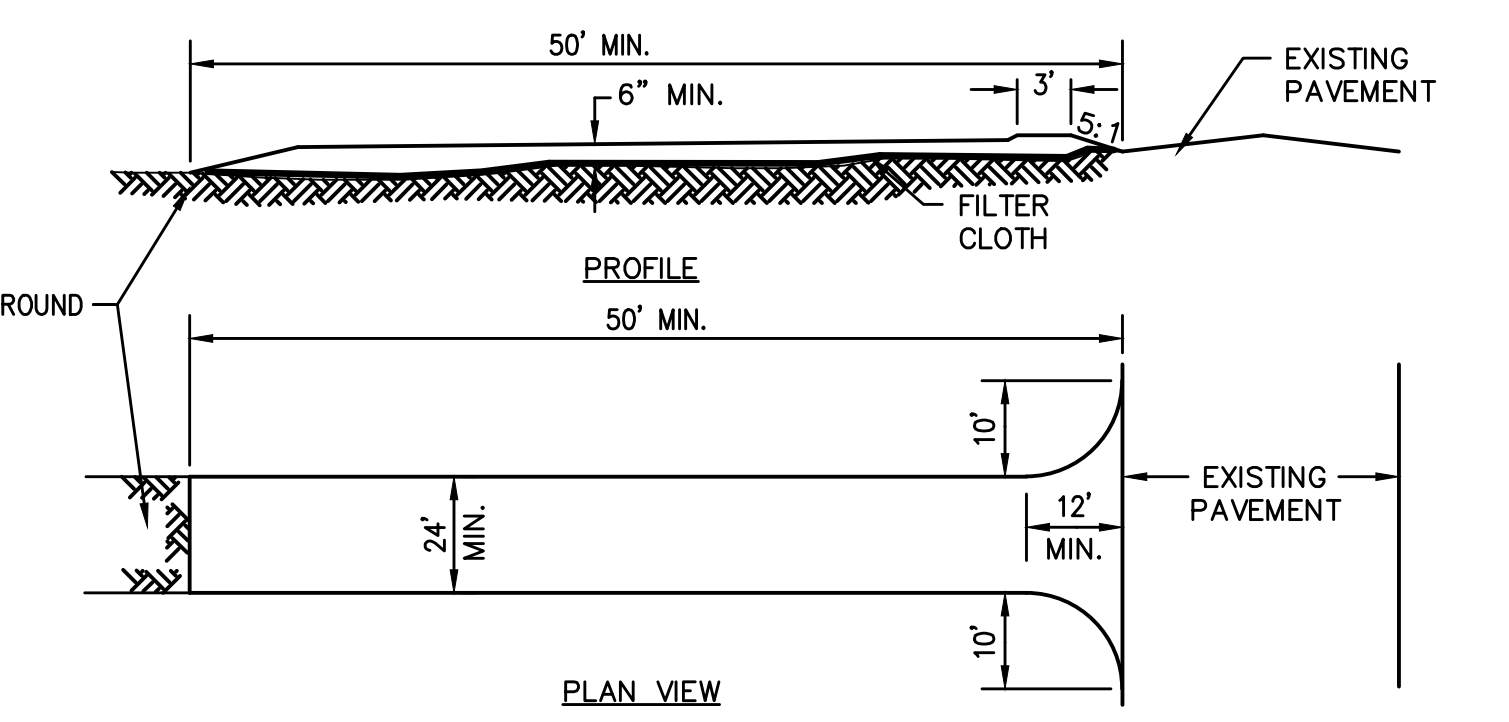

**CONSTRUCTION NOTES FOR STABILIZED CONSTRUCTION ENTRANCE**

- STONE SIZE - USE 2" STONE, OR RECLAIMED OR RECYCLED CONCRETE EQUIVALENT.
- LENGTH - AS REQUIRED, BUT NOT LESS THAN 50 FEET.
- THICKNESS - NOT LESS THAN 6 INCHES.
- WIDTH - 24 FOOT MINIMUM, BUT NOT LESS THAN THE FULL WIDTH AT POINTS WHERE INGRESS OR EGRESS OCCURS.
- FILTER CLOTH - WILL BE PLACED OVER ENTIRE AREA PRIOR TO PLACING OF STONE. FILTER CLOTH WILL NOT BE REQUIRED ON A SINGLE RESIDENCE LOT.
- SURFACE WATER - ALL SURFACE WATER FLOWING OR DIRECTED TOWARD CONSTRUCTION ENTRANCES SHALL BE PIPED ACROSS THE ENTRANCE. IF PIPING IS IMPRACTICAL, A MOUNTABLE BERM WITH 5:1 SLOPES WILL BE PERMITTED.
- MAINTENANCE - THE ENTRANCE SHALL BE MAINTAINED IN A CONDITION WHICH WILL PREVENT TRACKING OR FLOWING IF SEDIMENT ONTO PUBLIC RIGHTS-OF-WAY. THIS MAY REQUIRE PERIODIC TOP DRESSING WITH ADDITIONAL STONE AS CONDITIONS DEMAND AND REPAIR AND/OR CLEANEST OF ANY MEASURES USED TO TRAP SEDIMENT. ALL SEDIMENT SPILLED, DROPPED, WASHED OR TRACKED ONTO PUBLIC RIGHTS-OF-WAY MUST BE REMOVED IMMEDIATELY.
- WASHING - WHEELS SHALL BE WASHED TO REMOVE SEDIMENT PRIOR TO ENTRANCE ONTO PUBLIC RIGHTS-OF-WAY. WHEN CLEANING IS REQUIRED, IT SHALL BE DONE ON AN AREA STABILIZED WITH STONE AND WHICH DRAINS INTO AN APPROVED SEDIMENT TRAPPING DEVICE. PERIODIC INSPECTION AND NEEDED MAINTENANCE SHALL BE PROVIDED AFTER EACH RAIN.

**2 STABILIZED CONSTRUCTION ENTRANCE**  
SCALE: NOT TO SCALE

**NOTES:**

INSTALLATION: WHEN INSTALLING RUNNING LENGTHS OF COMPOST SOCKS, BUTT THE SECOND SOCK TIGHTLY AGAINST THE FIRST. DO NOT OVERLAP THE ENDS. STAKE THE SOCKS AT EACH END AND FIVE FOOT ON CENTER.

STAKES SHOULD BE DRIVEN THROUGH THE MIDDLE OF THE SOCK, LEAVING 2 - 3 INCHES OF THE STAKE PROTRUDING ABOVE THE SOCK AND AT LEAST 12" IN THE GROUND. WHEN COMPOST SOCKS ARE USED FOR FLAT GROUND APPLICATIONS, DRIVE THE STAKES STRAIGHT DOWN. WHEN INSTALLING WATTLES ON SLOPES, DRIVE THE STAKES PERPENDICULAR TO THE SLOPE.

DRIVE THE FIRST END STAKE OF THE SECOND SOCK AT AN ANGLE TOWARD THE FIRST SOCK IN ORDER TO HELP ABUT THEM TIGHTLY TOGETHER.

**INSTALLATION NOTES:**

- COMPOST SOCKS SHALL BE INSTALLED PRIOR TO ANY LAND-DISTURBING ACTIVITIES.
- COMPOST SOCKS SHALL BE "SILT SOCK", "FILTERSOX" OR OTHER APPROVED FILTER FABRIC SOCK.
- COMPOST SOCKS SHALL BE FILLED WITH WOOD CHIPS OR COMPOST. SEE SPECIFICATIONS FOR APPROVED COMPOSITION OF WOOD CHIPS OR COMPOST.
- NOT FOR USE IN CONCENTRATED FLOW AREAS.
- COMPOST SOCKS SHALL BE INSTALLED PER MANUFACTURERS SPECIFICATIONS.
- ON SLOPES, COMPOST SOCKS SHOULD BE INSTALLED ON CONTOUR WITH A SLIGHT DOWNWARD ANGLE AT THE END OF THE ROW IN ORDER TO PREVENT PONDING AT THE MID SECTION.
- RUNNING LENGTHS OF SOCKS SHOULD BE ABUTTED FIRMLY TO ENSURE NO LEAKAGE AT THE ABUTMENTS.
- COMPOST SOCK SHALL BE IN CONSTANT CONTACT WITH THE GROUND SURFACE.
- WOOD STAKES SHALL BE USED TO SECURE THE WATTLES. 1/2" TO 5/8" REBAR IS ALSO ACCEPTABLE. BE SURE TO USE A STAKE THAT IS LONG ENOUGH TO PROTRUDE SEVERAL INCHES ABOVE THE WATTLE.

**6 COMPOST OR SILT SOCK INSTALLATION DETAIL**  
SCALE: NOT TO SCALE

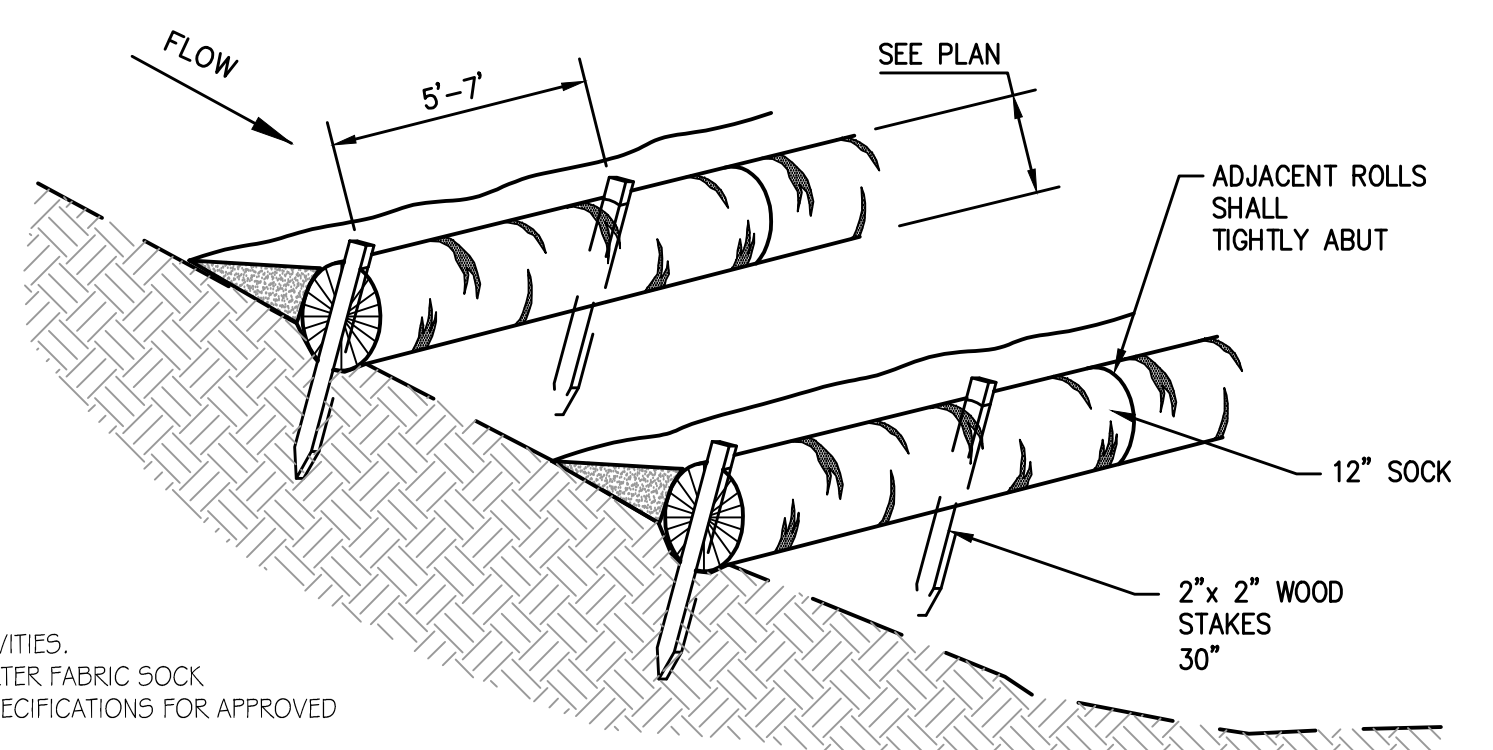

**COMPOST SOCKS - DETAIL A**

MAINTENANCE: SEDIMENT ACCUMULATED BEHIND WATTLE SHALL BE REMOVED WHEN SEDIMENT HAS ACCUMULATED TO ONE-HALF THE DIAMETER OF THE WATTLE.

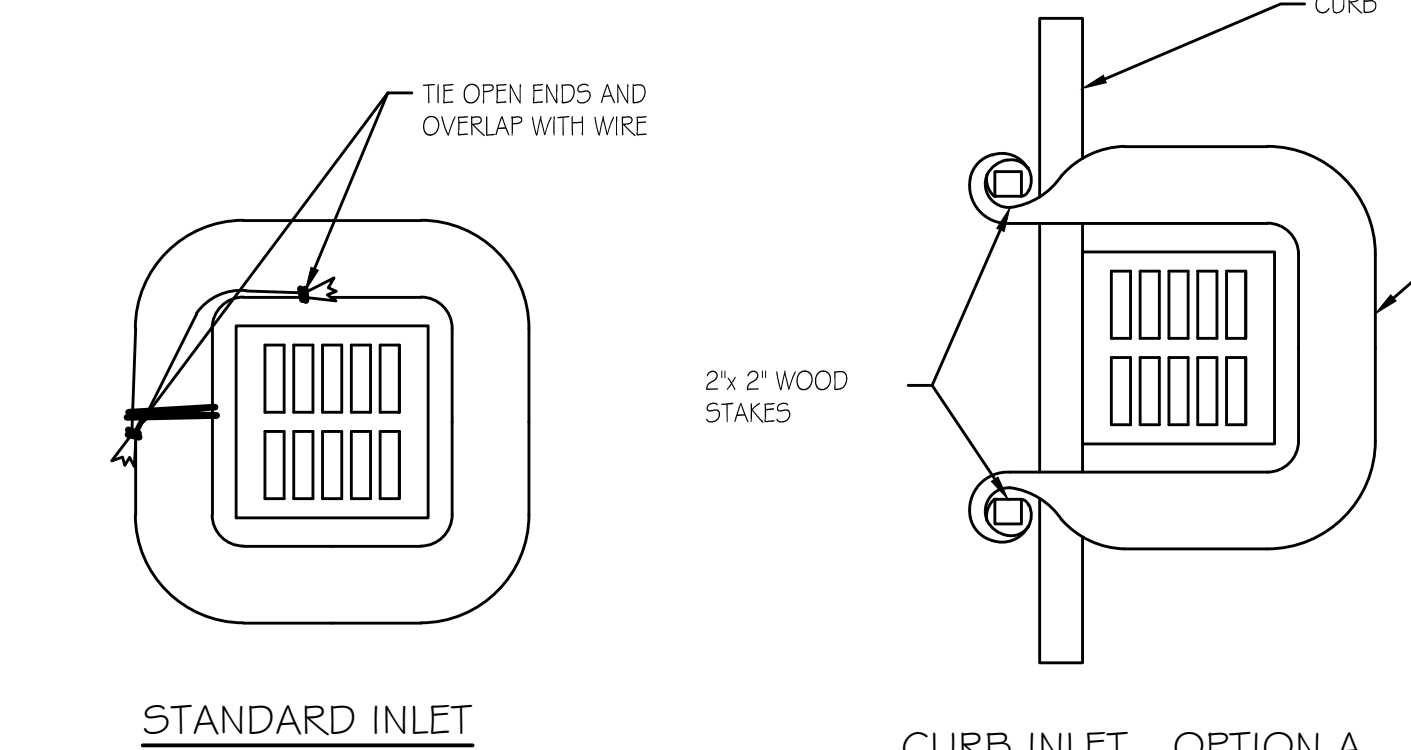

**INSTALLATION NOTES:**

- COMPOST SOCKS SHALL BE INSTALLED PRIOR TO ANY LAND-DISTURBING ACTIVITIES.
- COMPOST SOCKS SHALL BE "SILT SOCK", "FILTERSOX" OR OTHER APPROVED FILTER FABRIC SOCK.
- COMPOST SOCKS SHALL BE FILLED WITH WOOD CHIPS OR COMPOST. SEE SPECIFICATIONS FOR APPROVED COMPOSITION OF WOOD CHIPS OR COMPOST.
- COMPOST SOCKS SHALL BE INSTALLED PER MANUFACTURERS SPECIFICATIONS.
- COMPOST SOCK SHALL BE IN CONSTANT CONTACT WITH THE GROUND SURFACE.
- WOOD STAKES SHALL BE USED TO SECURE THE WATTLES. 1/2" TO 5/8" REBAR IS ALSO ACCEPTABLE. BE SURE TO USE A STAKE THAT IS LONG ENOUGH TO PROTRUDE SEVERAL INCHES ABOVE THE WATTLE.
- EXCESS FABRIC SHALL BE WRAPPED AROUND THE STAKES.
- FOR INLETS NOT ON A CURB THE COMPOST SOCK SHALL BE TIED OFF AT BOTH ENDS WITH THE WIRE AND OVERLAPPED TO PROVIDE SUITABLE PROTECTION.

**4 COMPOST SOCK INLET PROTECTION (IP-1) DETAIL**  
SCALE: NOT TO SCALE

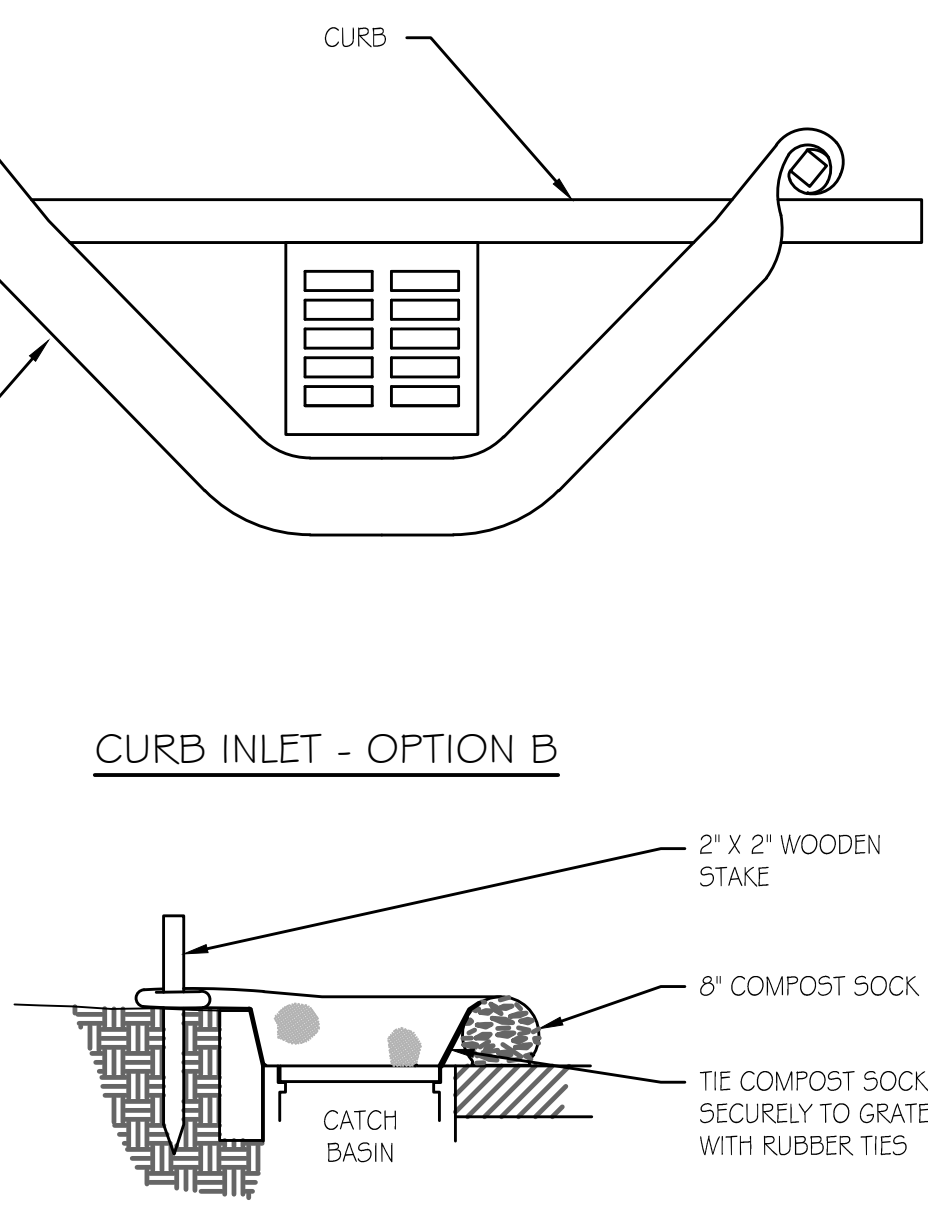

**MAINTENANCE:**

SEDIMENT ACCUMULATED BEHIND WATTLE SHALL BE REMOVED WHEN SEDIMENT HAS ACCUMULATED TO ONE-HALF THE DIAMETER OF THE WATTLE.

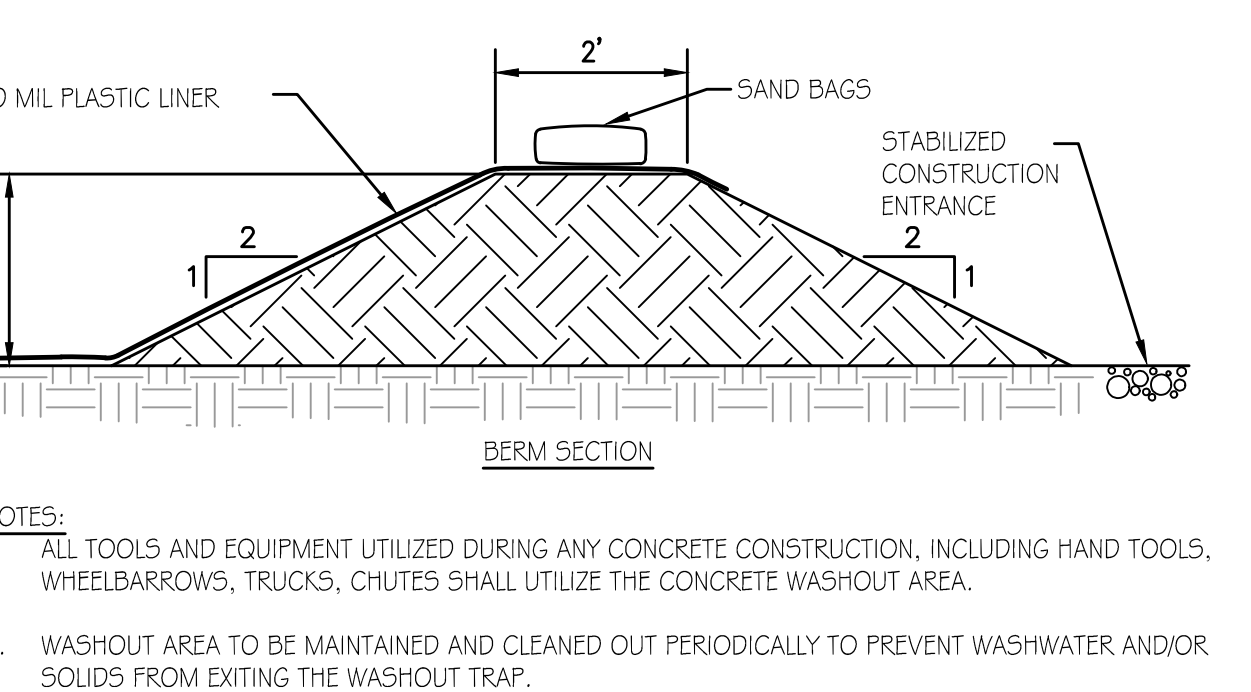

**1 CONCRETE WASH OUT DETAIL**  
SCALE: NOT TO SCALE

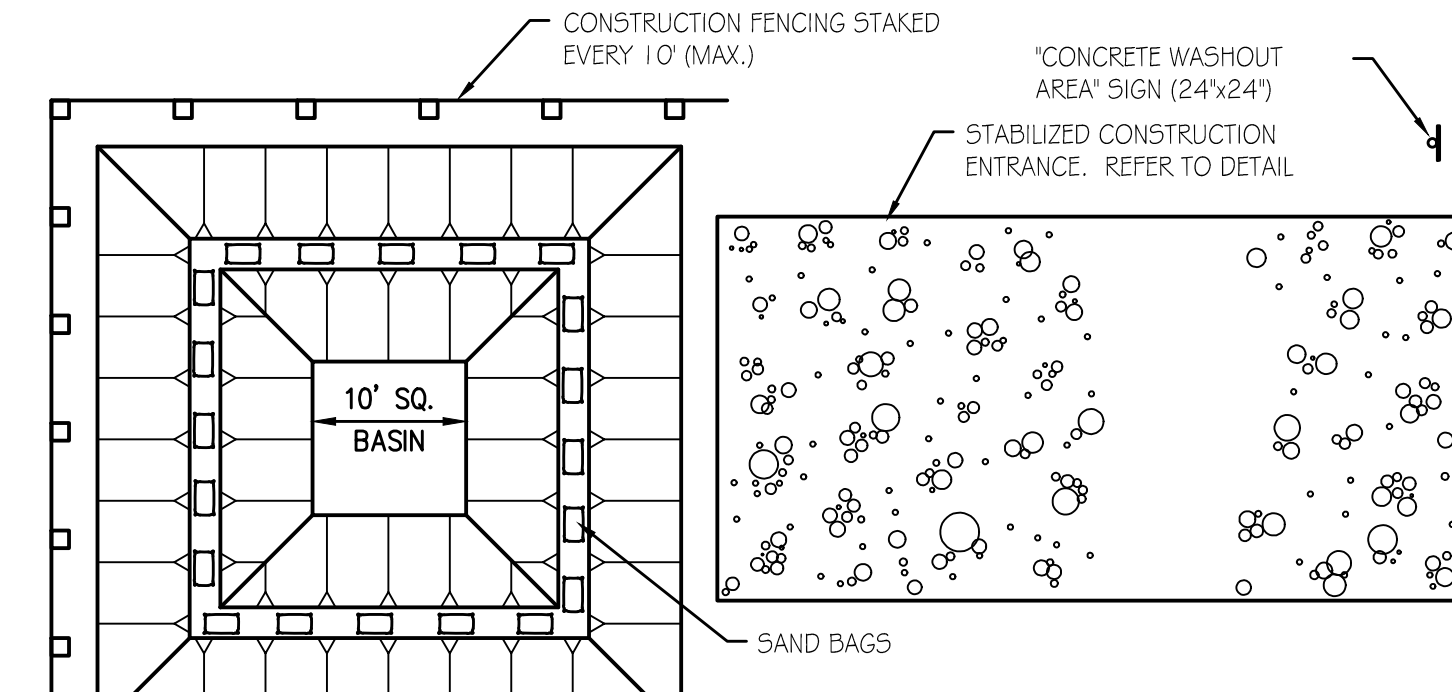

DRAWN BY :	AAI
CHECKED BY :	MBI
DATE :	6/01/2018
SCALE :	AS SHOWN
BY :	
DESCRIPTION OF REVISION:	
DATE:	
#	1
#	2
#	3
#	4
#	5
#	6
#	7
#	8
#	9
#	10

**HUNT ENGINEERS | ARCHITECTS | SURVEYORS**  
100 Hunt Center, Horseheads, New York 14845 P: 607-558-1000 F: 607-558-1800  
Office: Rochester | Horseheads | Townsends

**E&S DETAIL**  
**TOWNHOMES AT DRYDEN**  
**TRINITAS VENTURES**  
366 DRYDEN ROAD, ITHACA, NY 14850  
TOWN OF VARINA, TOMPKINS COUNTY, NY